

[www.BibleForChildren.org](http://www.BibleForChildren.org)

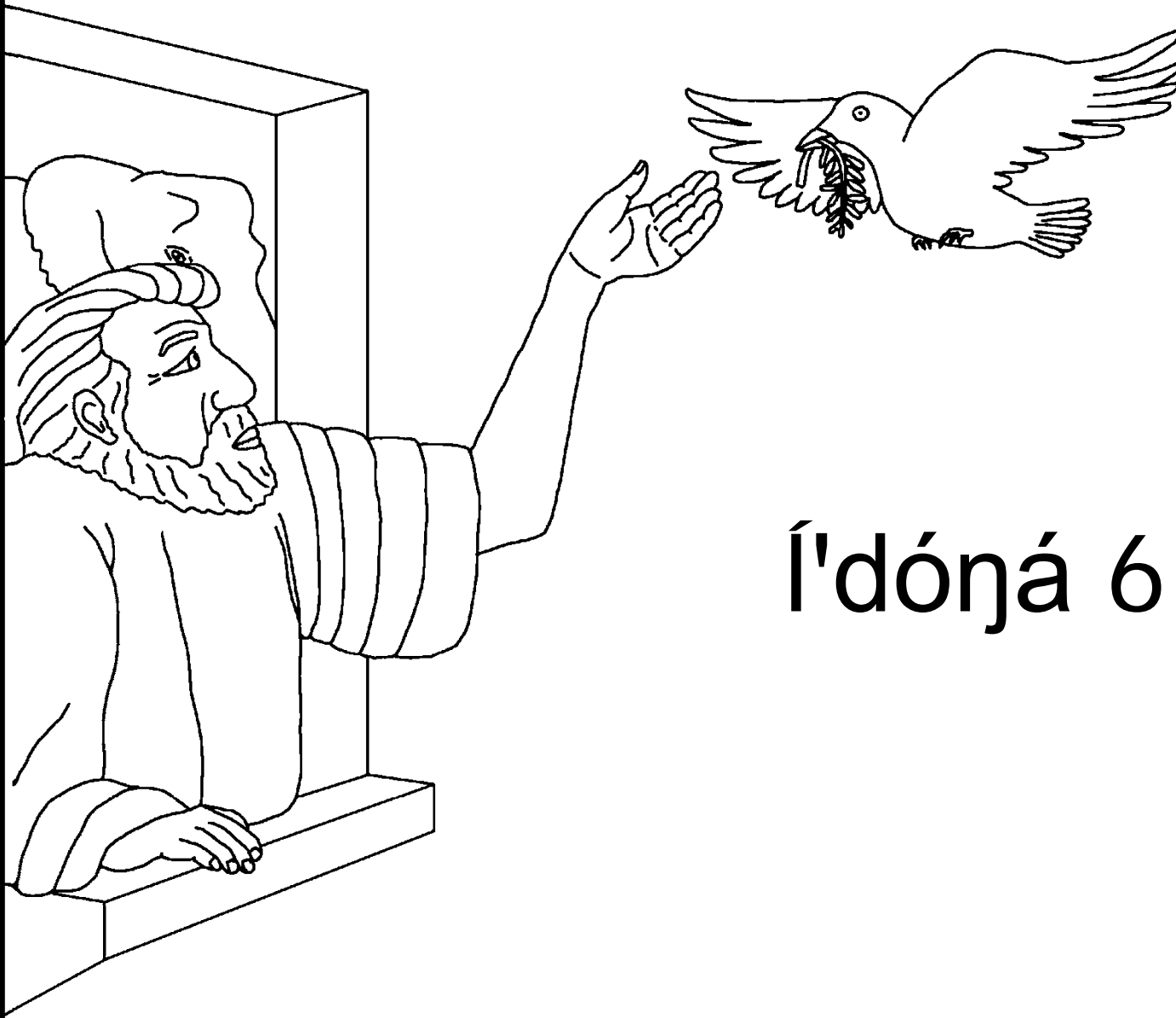

Í'dóná 6



' Dī āwí Núwā dṛī ' i. Núwā ándrá  
' bá mgbā la, ' bā ándrá ásì 'ijò  
Ādróná dṛī ' bā dṛī gá āzila ri  
'ijò Ādróná dṛī kí vú ũbīlé rá.  
Ādróná ndre ' bá ru izalépi ũnókú  
dṛī gá ' dā ' dī kí ũmbā rú āzila  
gbíyā ĩ ' bā kí sī ' bá kí  
ũnzājó rī  
wókō pírí  
agá.



Ãdróná jọ Núwã ní, "Má umbé áma ásì ' bo,  
ma ' bá ùnókú dṛì gá ' dī kī ìlìkī pírì, ùnókú  
' bã gajó tré àlì àzìla ununuṅá ì ' badṛì sī rī  
sī, ma ùnókú ìlìkī ' bá ọrọ ' bá àrì  
trū rī abe rá, ọ ' dụ ì ' badṛì àšìjọ  
rī acá dó ' bo."

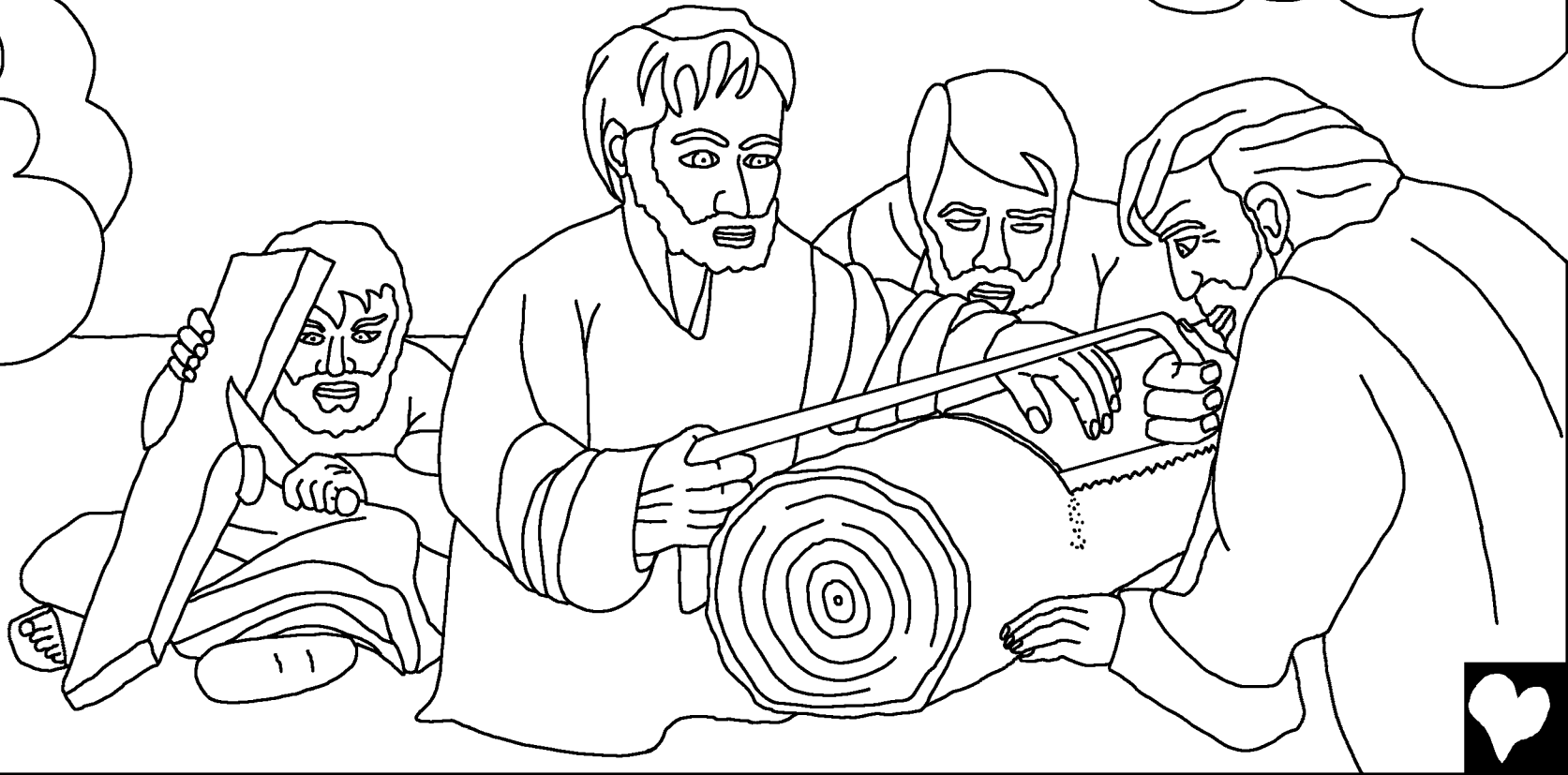

"Ijọ́ ' dī sī, mí idé í ' bó ãmbógó la b́awũ  
múké ãyí ' b́a fijó ala ǵa ku la sī, mí ụlị  
ala ndú-ndú, mí ãbĩ ụrụ ' bá la ' a la  
trũ ísékísé sī."

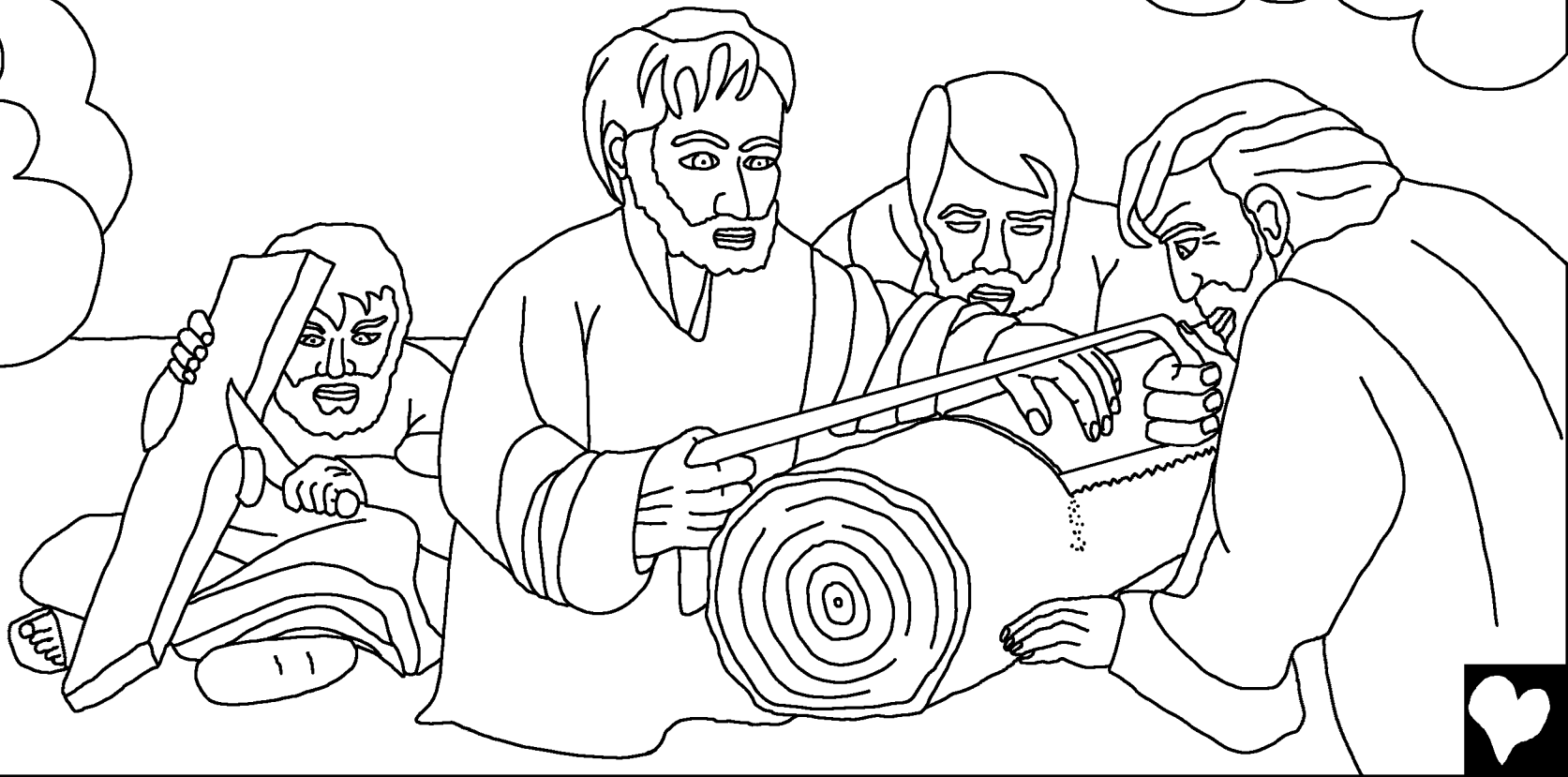

Mí idé í 'bô 'dĩ áni, ãzo  
la 'bã adru mítã 133,  
mmgbọ la 'bã adru  
mítã kãlĩ ãrĩ dĩrĩ ãrĩ,  
ãzo la  
lótré gâlé

rĩ 'bã  
adru mítã  
mụdrĩ dĩrĩ na.

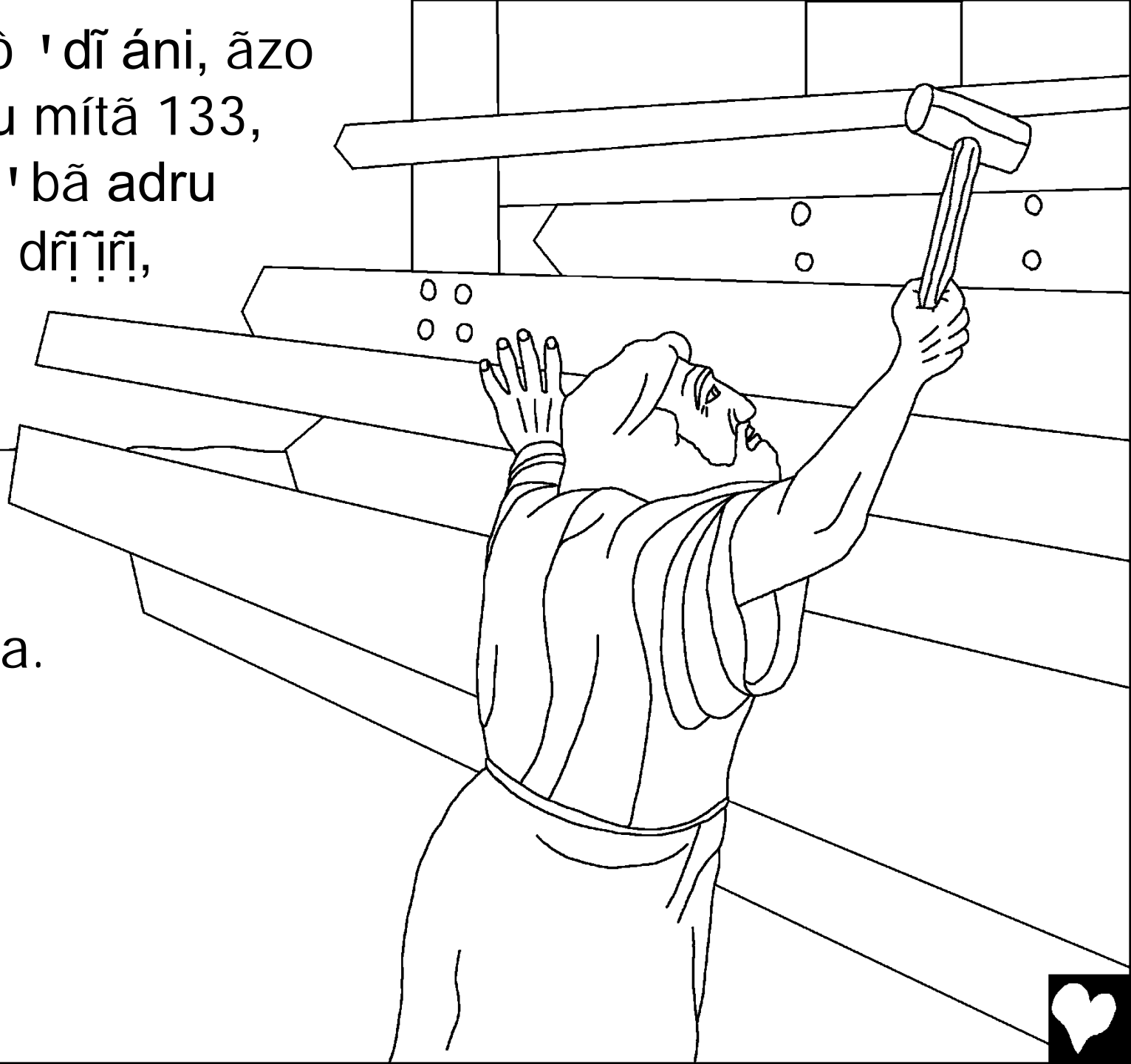

“Lě í ' dų ãkónã ũví ndú-ndú  
rĩ kí míní ' bá mí drįko gá  
rĩ kí abe ãzıla í ' dų vâ  
ãnãkpá pírí ' banî ãndĩ.”



Mí a ' dú ãnãkpá ùvì pírí ìrî-ìrî ágó rî kí ãronî rî kí abe  
í ' bó ãmbógó ' dī agá ' dōlé sī kí tã mbajó ídri rú ìyí  
ãmbógó ãngũ nzelépi ìndù trũ ' dī sī.

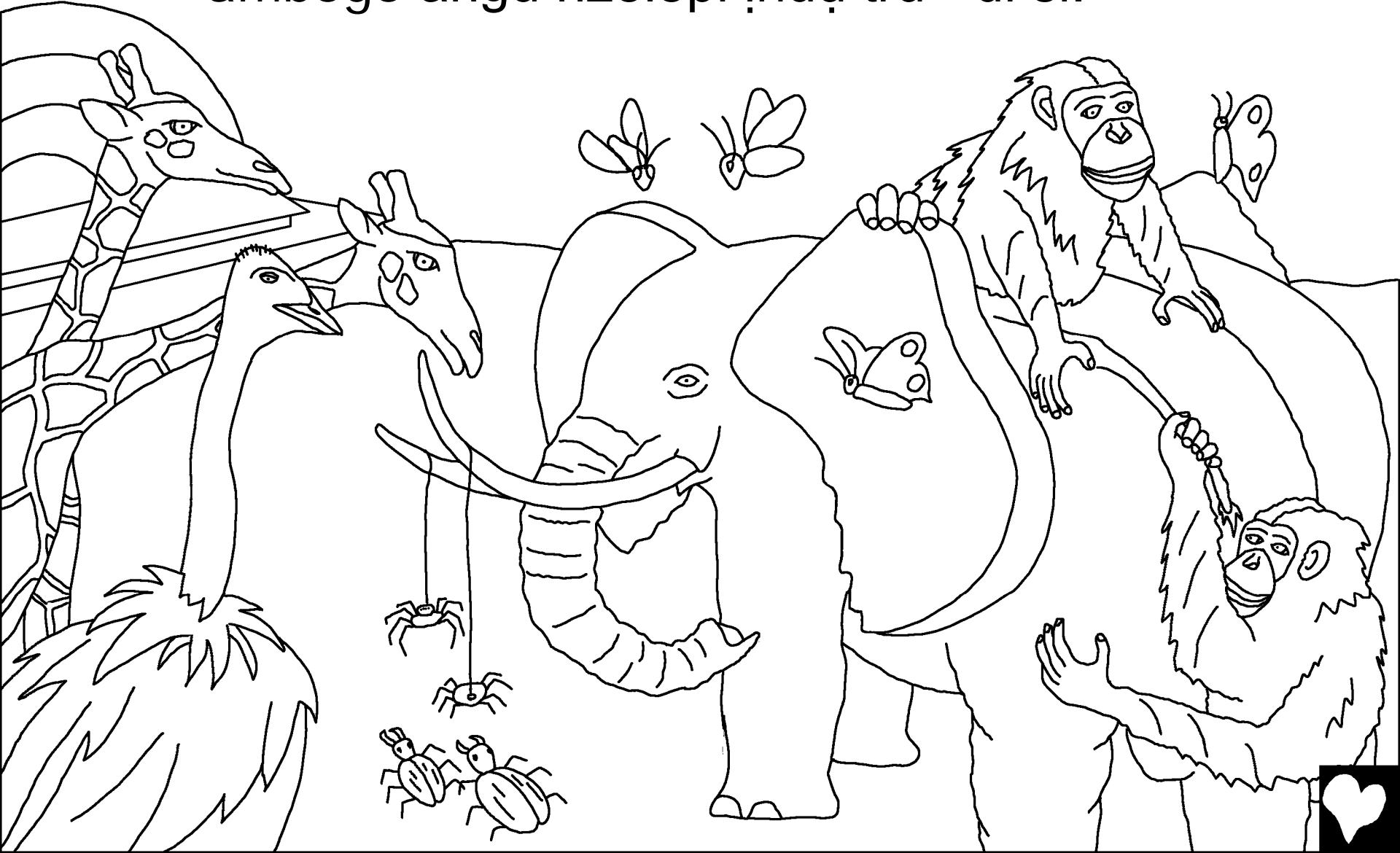

Í' dṽ ãñãkpá ũví ndú ndú ágó  
ãzıla ãrónĩ ãlá nalé  
nãñã rĩ kí ázĩrĩ-ázĩrĩ.

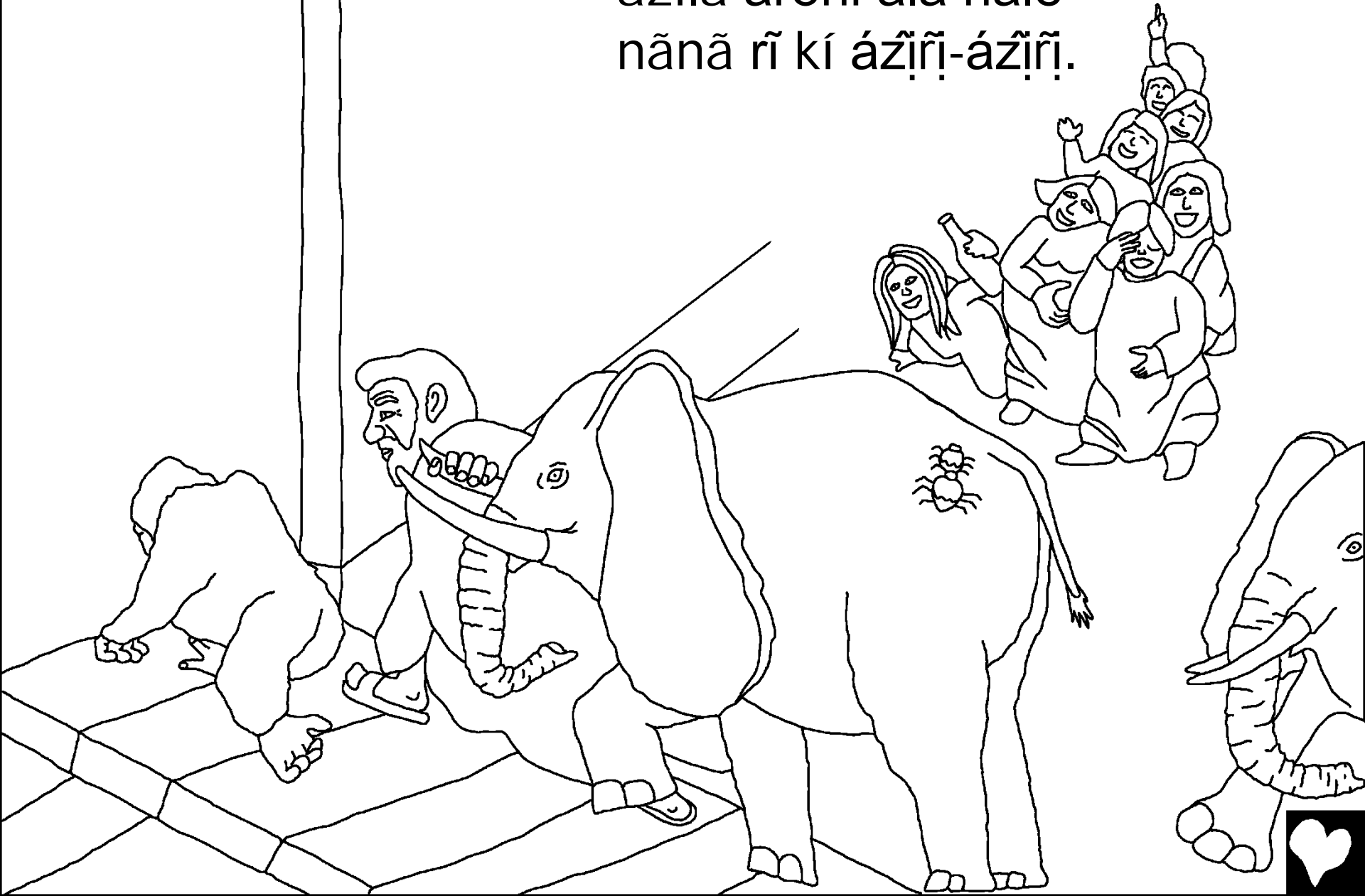

Í' dṽ vā ānākpá ũvī ndú ndú ágó āzila  
ārónī ālā kóru rī kí rī-īrī, āzila  
āriṅa ũvī ndú-ndú ágó āzila  
ārónī rī kí ázīrī-ázīrī sī kí  
tāmbajó ídri rú ũnókú dṽ gá  
' dā sī amújó kí  
ūriīdṽjó.



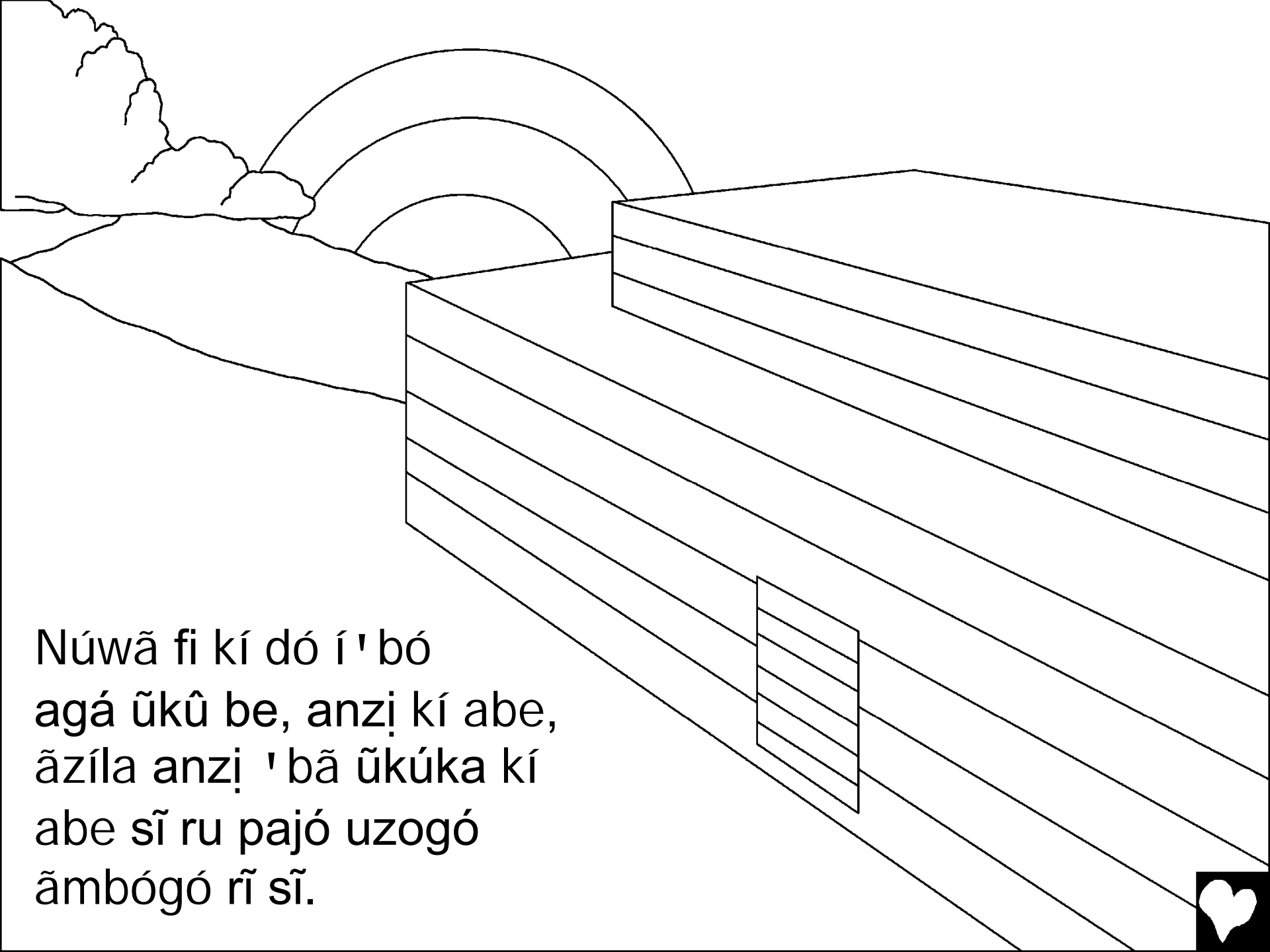

Núwā fi kí dó í ' bó  
agá ũkû be, anzi kí abe,  
ãzila anzi ' bã ũkúka kí  
abe sĩ ru pajó uzogó  
ãmbógó rĩ sĩ.



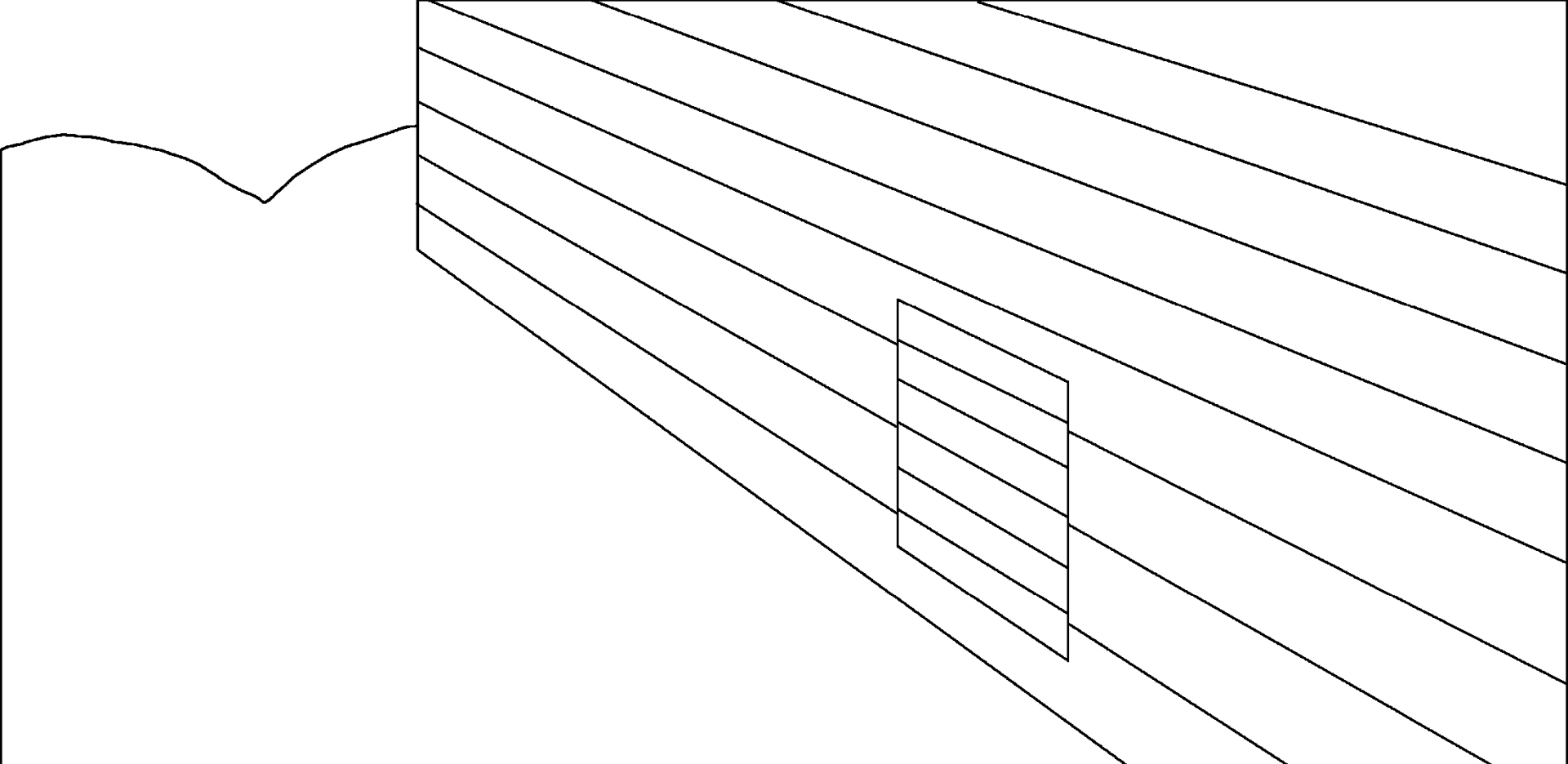

Núwã ' bā ílí la dó mụ calé  
600 ' bo, ãmbá ú ' dú mụdrị drị  
ázịrị ãmbá ãrị drị sīyị ãkpě dó  
vũ ãndụ gálé ãzıla únzị dó dẹrịsã  
uzogó drị ' bụ gálé rī kí tị mmgbọ.



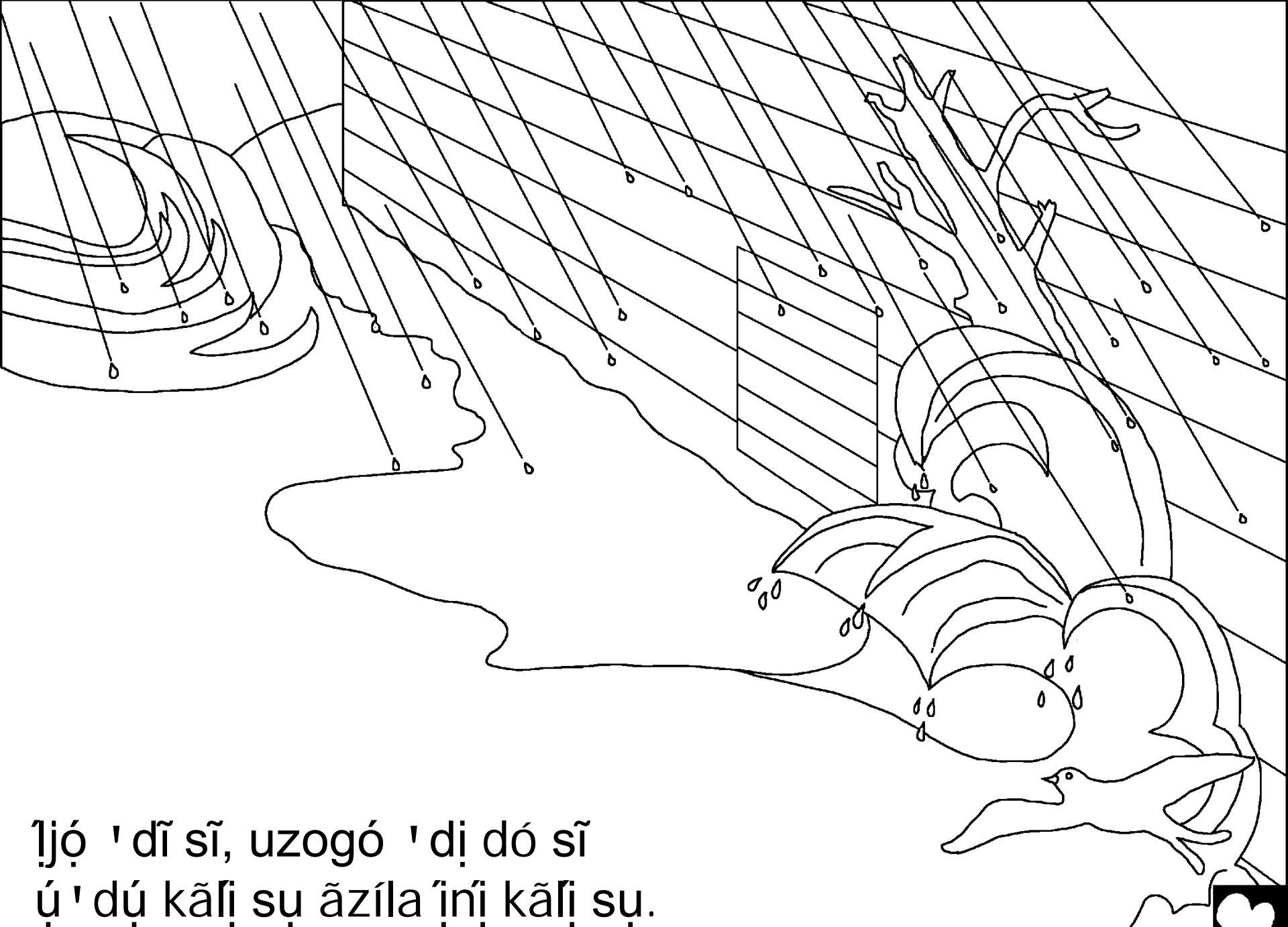

Ìjọ ' dī sī, uzogó ' dì dọ sī  
ú ' dú kǎlì sọ ãzíla ìnì kǎlì sọ.



ḶyḶ ' bā tų agá ųrųgá  
ųrųgá ' dḶ gá ' dā í ' bō  
atų dō ḶyḶ dḶ gá.



Uzogó ' bā āmbōgō sīīyī iti ' bé āmbogo āzombílikoko  
rī kī dī mīī-mīī. Āko pírí u ' álépi ídri āngū ā ' í dī gá ūlí  
sī rīīīkī kī pírí.



Ãdróná ũrã dó ïjọ Núwã dñi gá ãzila  
ãñãkpá ásé agá ãzila ñcọ agá u ' álépi  
ĩ ' di be í ' bó ãmbógó rĩ agá rĩ kí dñi gá,  
ãpě dô sĩ ãlúkúkũ tị ïyị ãmbógó ñlépi  
rĩ ní sĩ ru umvijó.

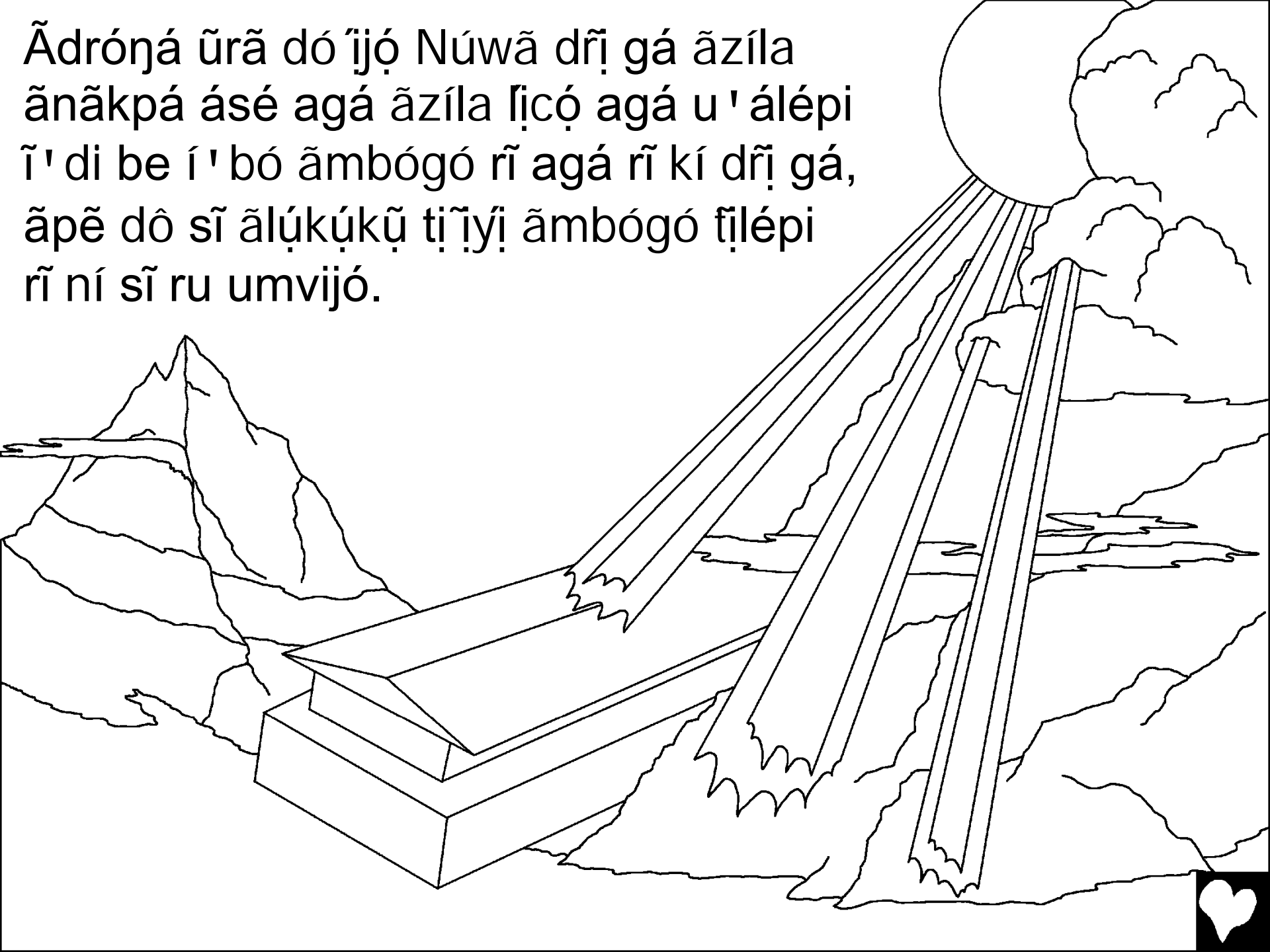

Ụ ' dụ kǎlị sụ vúlé gá Núwā n̄zị dọ dẹrịsā í ' bó  
ĩ ' di ' bā idélé rĩ d̄rị, āzıla pē dọ

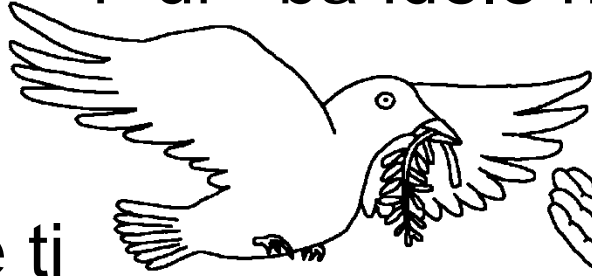

kúrúke tị  
āmvêlé ala gāsī āzıla  
kúrúke ri ungalé ándrá úrú  
kpere ãyĩ ' bā nzụ agá ãnókú  
d̄rị gá ' dǎá. ' Dǎ ' bā ãngúkú  
gá pē vā ālĩ ' bō tị amájó la ãyĩ  
nzụ vũ d̄rị gá ' dǎá rá yā rĩ.



Ìmbá ìrì rī 'bā ú' dú kālì ìrì dṛì ázìrì sī, ùnókù dṛì 'i  
dó ã 'í ru. Ādróná jọ dó Núwā nī, "Mí ãfū dó  
í 'bó agâlé rī sī ãmvé, mi ùkú mídṛì be  
āzila anzi kí ùkúka  
ĩ 'badṛì kí abe.



Núwā sị dó sī ǎlītárl  
ídétánǎ idéjó rī  
Úpí nī, a ' dú dó  
ǎnǎkpá pírí ũví  
ndú-ndú ǎlá rī kí  
ǎzí ǎzíla ǎrínǎ ǎlá  
rī kí abe, sī ídétánǎ  
ivélé ivê rī idéjó.





' Dã ' bã ũngúku  
gá ãdróná jọ, "Ijó  
i ' dalépi la ícétánjá  
ru tị icíma ãma  
drĩdrĩnĩ gá ' dã mí be  
ãzıla ãko ídri trũ adrulépi  
ĩmi abe mání ' bãlé ĩmi abe

pírí rĩ ' bã ícétánjá jã  
' dã rĩ gápi ' dĩ, á ' bã  
gérĩ ũrú ' bũ agá. Ĩ ' di  
ícétánjá mání tị icíma  
drĩ ukólépi ku rĩ azijó  
míní ãko ídri trũ rĩ  
kí abe pírí ụ ãnókú  
drĩ gá ' dã rĩ.



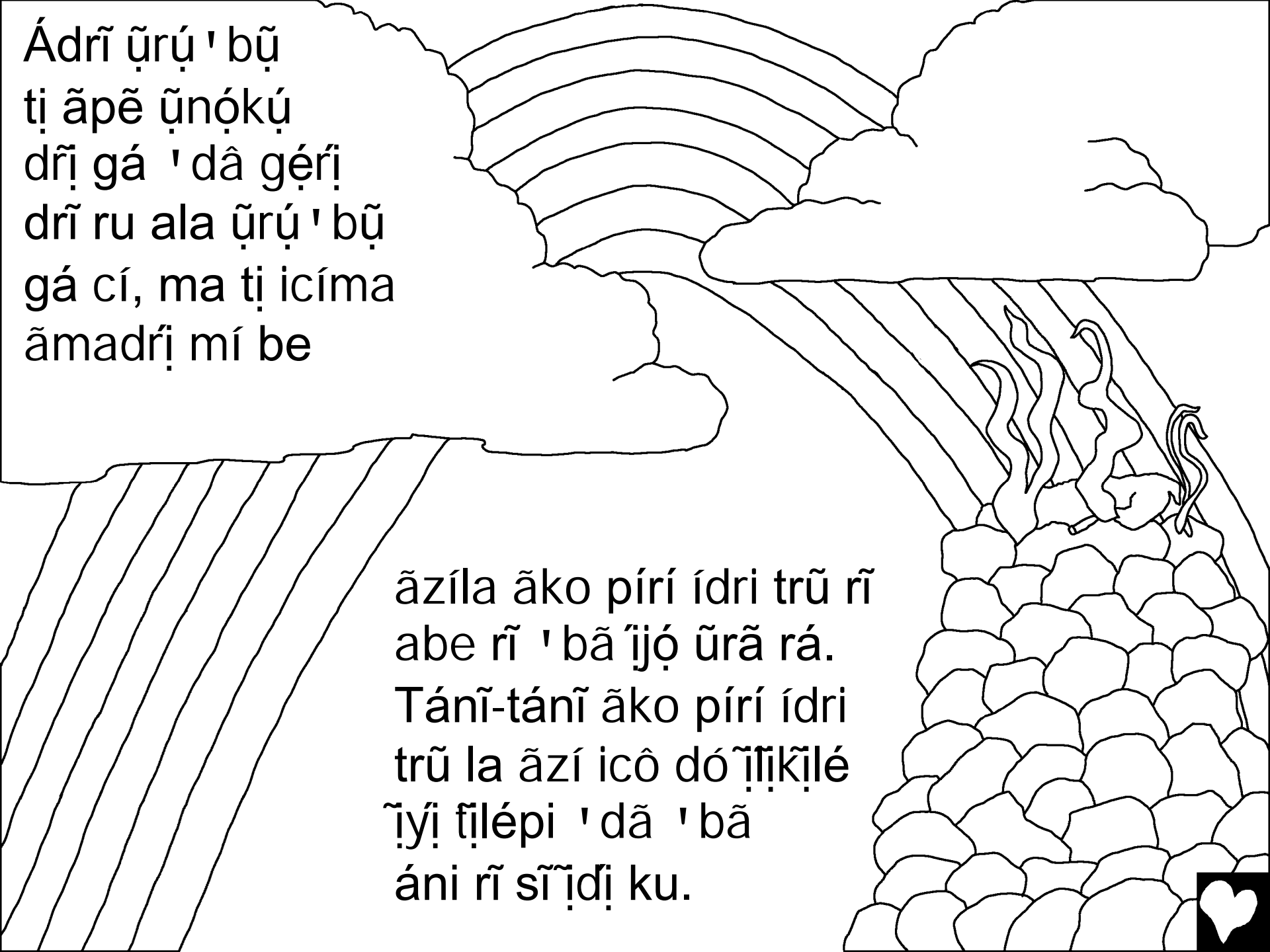

Ádrĩ ũrú ' bū  
tị ãpě ũnókú  
dřĩ gá ' dā gęřĩ  
dřĩ ru ala ũrú ' bū  
gá cí, ma tị icíma  
ãmadřĩ mí be

ãzıla ãko pírĩ ídri trũ rĩ  
abe rĩ ' bã ĩjọ ũrã rá.  
Tánĩ-tánĩ ãko pírĩ ídri  
trũ la ãzí icô dó ĩřĩkĩlé  
ĩyĩ řĩlépi ' dā ' bã  
áni rĩ sĩřđĩ ku.



' Dã ' bã ãngúkú gá  
Ãdróná wi sūsú Núwã  
' baní ngòpìka abe ãzìla jọ,  
"Ìtì ãzìla ìkpẹ wẹwẹ rú, ìga  
ũnókú dṛì gá ' dâ tré.



Anzị Núwā dṛī āfūlépi  
í ' bó agâlé rĩ kí: Sémĩ ' i, Hámũ  
' i āzıla Yáfētĩ ' i. (' Bá Kānānĩ rú  
rĩ ' bā átẹpi gápi umvelé Hámũ ' i  
' dī.) Anzị Núwā dṛī na ' dī kí dó  
bāsĩ á ' bĩ ' bá pírí irélepi  
ũnókú dṛī gá ' dā rĩ  
' badṛĩ kí.

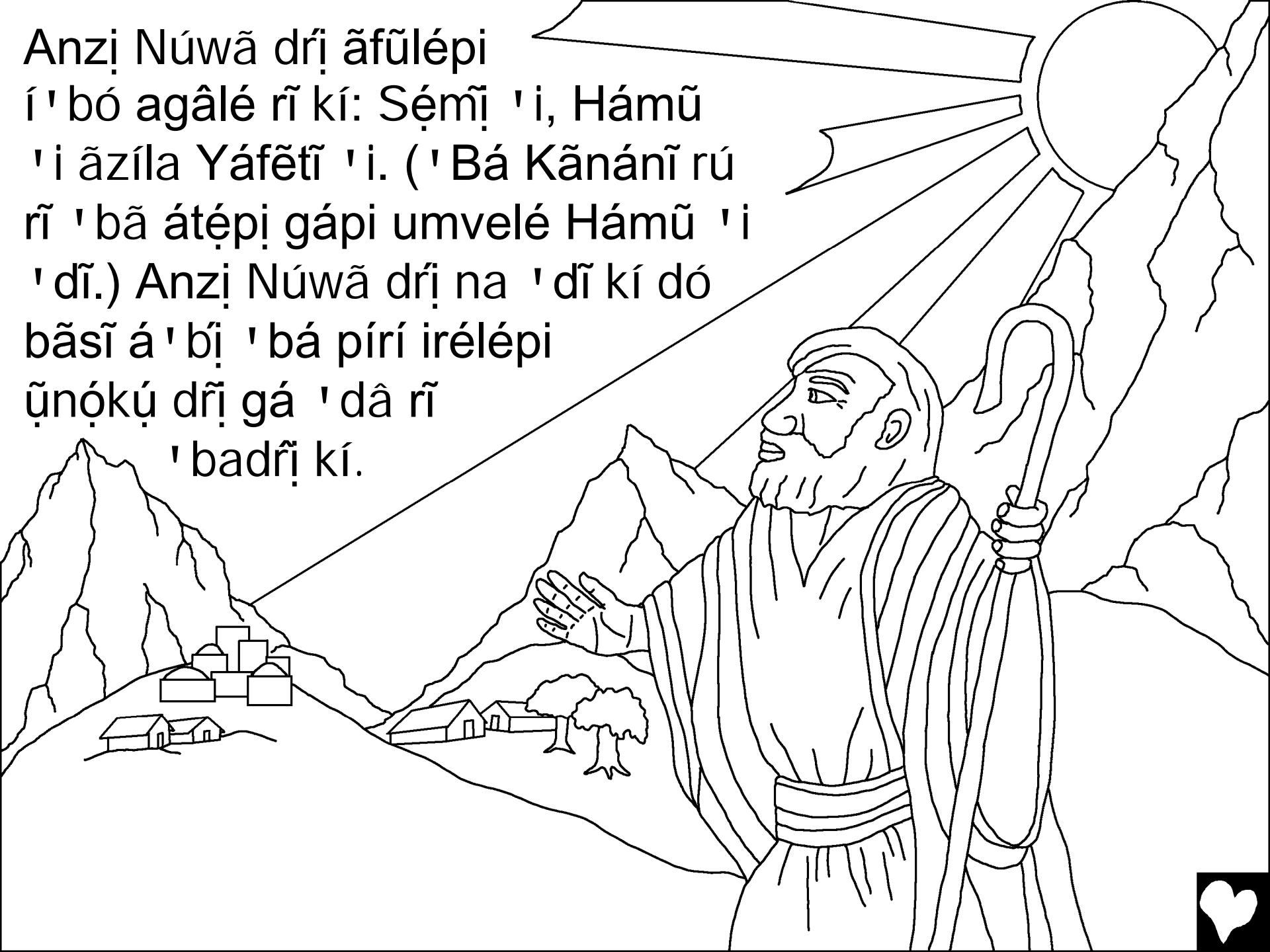

Ãdrónjã 'bã 'bã ãnókù gá 'dĩ kí lějó  
ambamba rĩ sĩ, ãpě ĩ'di 'bã Ngópi  
kílímgbí ãlu rĩ tị, 'bã píri ãlu-ãlu  
ĩ'di ãĩlẹpi rĩ 'bã ja kí dĩ ku,  
wó 'ba ịsù kí sĩ ịdri  
ukólẹpi ku rĩ 'i.



Rúmĩ 3:23

Íjọ ' dī sī, ' bá pírí idé kí ũnzí rá, ãzıla icó kí  
calé dīzã Ādróná drī gá rī gá ku.

Rúmĩ 6:23

Ā ' dusīku ũyá íjọ ũnzí drī gá rī ĩ' di drã, wó fětáná  
ãjẹ kóru Ādróná ' bã félé rī ĩ' di ídri ukólépi ku Úpí  
ãma ãni Kúrísītō Yésū agá rī ' i.

Ĕbūrānáyã 9:27

Cécé ' bání drājó pãlé ãlu sī fijó íjọ līnã gá rī áni,

Ĕfésō 2:8,9

Ā ' dusīku pa ãma ásī'ìgbẹ ĩ' didrī gá rī sī, ' dī ã rītáná sī  
adru íjọ angálépi ĩmidrī la ku, ĩ' di ãko Ādróná ' bã félé nī rī  
' i; adru ãzī nğaná sī ku, ' bá ãzī ipí dó sī ru íjọ la sī ku.



Rúmī 10:9,10

Íjọ ' dī sī, ídrī i ' da la Yésū ĩ ' di Úpí ' i ími tị sī, ãzıla mí ã ' ĩ  
ími ásị gá Ādróná inga ĩ ' di ídri ' bá drǎlépi rá rĩ kí drĩdrĩnĩ  
gá rá íni, mi ími pa rá. Ásị sī ' bá la 'ijọ ã ' ĩ rá sī adrujó ' bá  
ǎlá ru Ādróná dřilẹ gá, wó tị sī ĩ ' di i ' da la sī patáná ìsújó.

Yōhánǎ 3:16,17

Ādróná ' bǎ ' bá ũnókú gá ' dī kí lějọ ambamba rĩ sī, ãpě  
ĩ ' di ' bǎ Ngọpị kílímgbí ǎlu rĩ tị, ' bá pírí ǎlu-ǎlu ĩ ' di ã ' ĩlépi  
rĩ ' bǎ ja kí dřĩ ku, wó ' ba ìsú kí sī ídri ukólépi ku rĩ ' i.

Ādróná ãpě Ngọpị tị amúlé ' bá ũnókú gá  
' dī kí 'ijọ ìjọ la ku, be la rá la kí pajó.



## 1 Yõhãnã 5:11-13

Ìjọ́ vù nzelé rĩ ã' di ' dĩ: ãdróná fẽ ãmaní ídri ukólépi ku rĩ ' i, ãzıla ídri ' dĩ angá Ngọpị Yẹsũ agá. Ìjọ́ ' dĩ sĩ, ' bá drĩ adru ãdróná ' bã Ngọpị agá, ã' di ídri ' dĩ trũ. Wó ' bá ãdróná Ngọpị ã ã' lẹpi ku rĩ, ã' di ídri ' dĩ kóru. ãsĩ' ãjọ́ ' dĩ kí ãminí ãmi ' bá ãdróná ' bã Ngọpị rù ã ã' lẹpi rá ' dĩ, ãmi dó sĩ nĩ la ãmi ídri ukólépi ku rĩ trũ.



Í' dóná 6 – 10

Storyline by: Edward D. Hughes

Illustrated by: Byron Unger, Lazarus  
and Alastair Paterson

Adapted by: M. Maillot; Tammy S.

Aringa Bible (Iuc) © 2018, Wycliffe Bible Translators, Inc.  
All rights reserved.

<https://www.bible.com/en-GB/bible/2341/MAT.1>

©2026 Bible for Children, Inc.

[www.M1914.org](http://www.M1914.org)

[www.bibleforchildren.org](http://www.bibleforchildren.org)

