

[www.BibleForChildren.org](http://www.BibleForChildren.org)

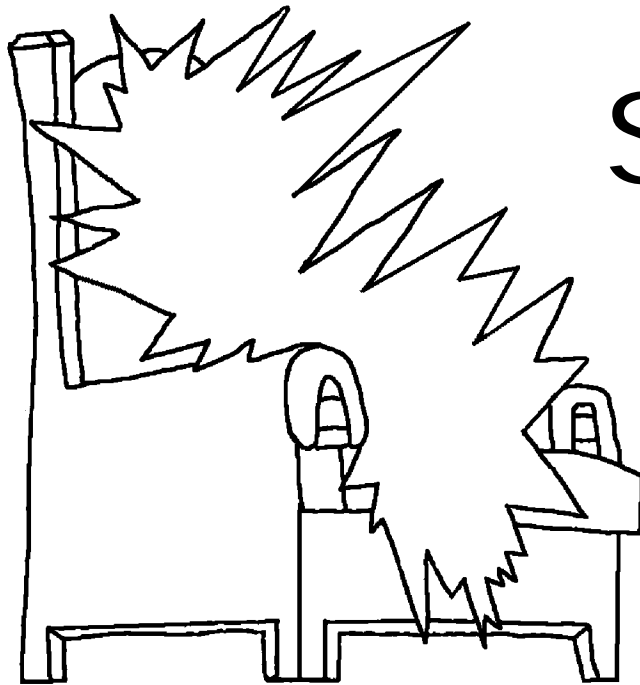

## San Mateo 14



To bajiro Pedrore ãre yigajanocõari ado bajiro yuare  
yigoticami Jesús quẽna: —Buto tuoãarejaibeticõaña  
mãa. Diore ãre ajitirũnucõari, yure quẽne ajitirũnũña.  
Yu jacu ya vijure jairo mãa ñarotijaeri ñaja ti.



To ti bajibetijama, m̄are gotibetiboḡija ȳ. Toj̄ m̄a  
ñarotire m̄are quẽnoyuḡ var̄ bajaiaja ȳ. Toj̄ m̄a  
ñarotijār̄ire quẽnogajanoc̄ari, quẽna ḡame vadir̄c̄ija  
ȳ. "Toj̄re ȳ ñaro ȳ r̄aca ñarãjaro" yiḡ m̄are juaḡ  
ejar̄c̄ija ȳ quẽna.



Үм Juan, Jesucristore ajitirũnugũ ñari, m̃a ym  
ñaja ym. Ìre ajitirũnugũ ñari, m̃are bajirone  
rojose tãm̃oaja ym. Gãjerã rojose ymre

ĩna yiboajaquẽne, m̃are  
bajirone ìre ajitirũnucõa



ñaja ym  
quẽne.



Mani ɛjɛre cɛdirã jediro to bajiro rĩne  
bajirũgũroti ñaja. Tirũmɛjɛ Dios ocare yɛ  
gotimasiojare, "Rojose tãmɛoato" yirã,

Patmos vãme cɛtiyoajɛ  
yɛre cũcama ñna.

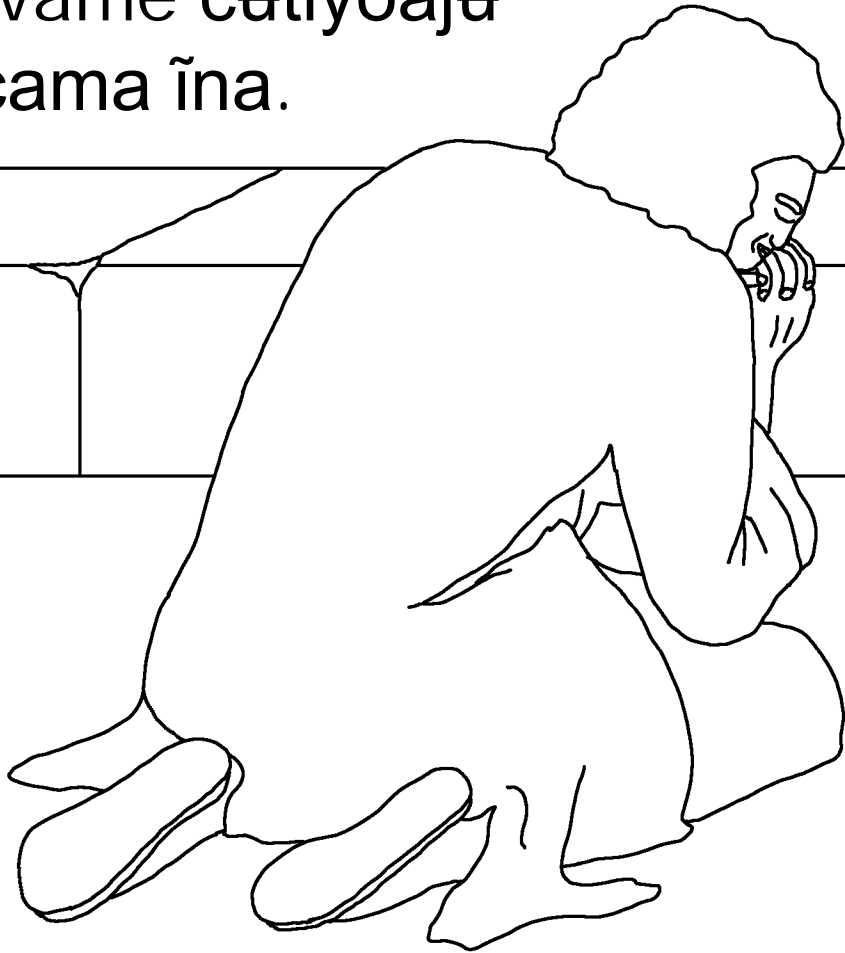

To bajiro ti yirone, Esp'iritu Santo sʘorine ẽ vecajʘ  
ejagʘre bajiro ıacajʘ yʘ. Tojʘ sıgũ, rotigʘ ı rujiri  
cũmurore rujicami.

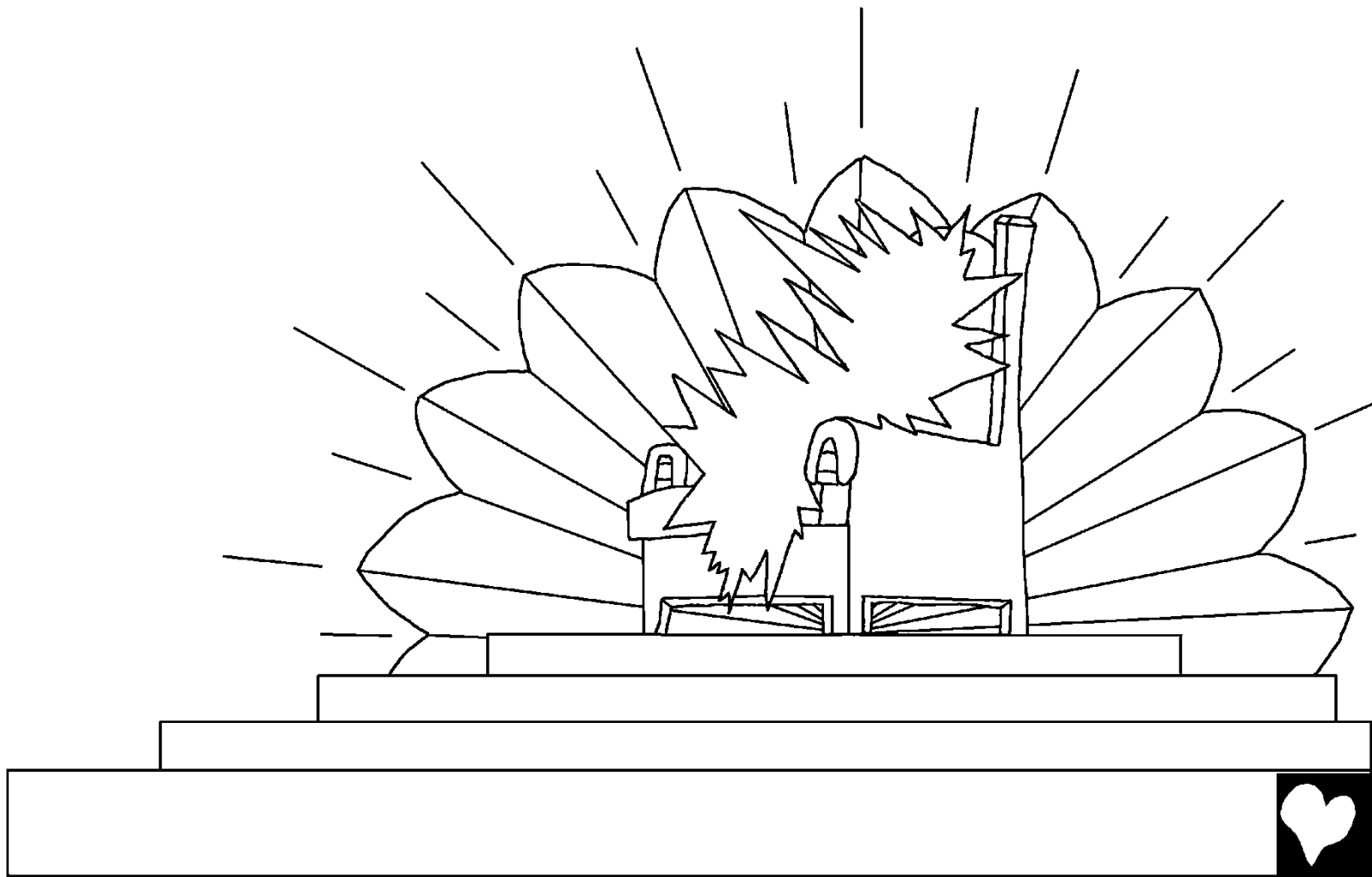

To bajiro ñna yisere ajicõari, õ vecana, adi  
macarucuroana quẽne, adi sita ãnerocana  
quẽne, moa riagariana quẽne,  
ñajedirone, ucjã ya cãmuro  
rujigũre, to yicõari, oveja macũre  
bajiro rijabosacacũre quẽne  
quẽnaro ñna yirũcũbũo basacatire  
ajicajũ yũ.

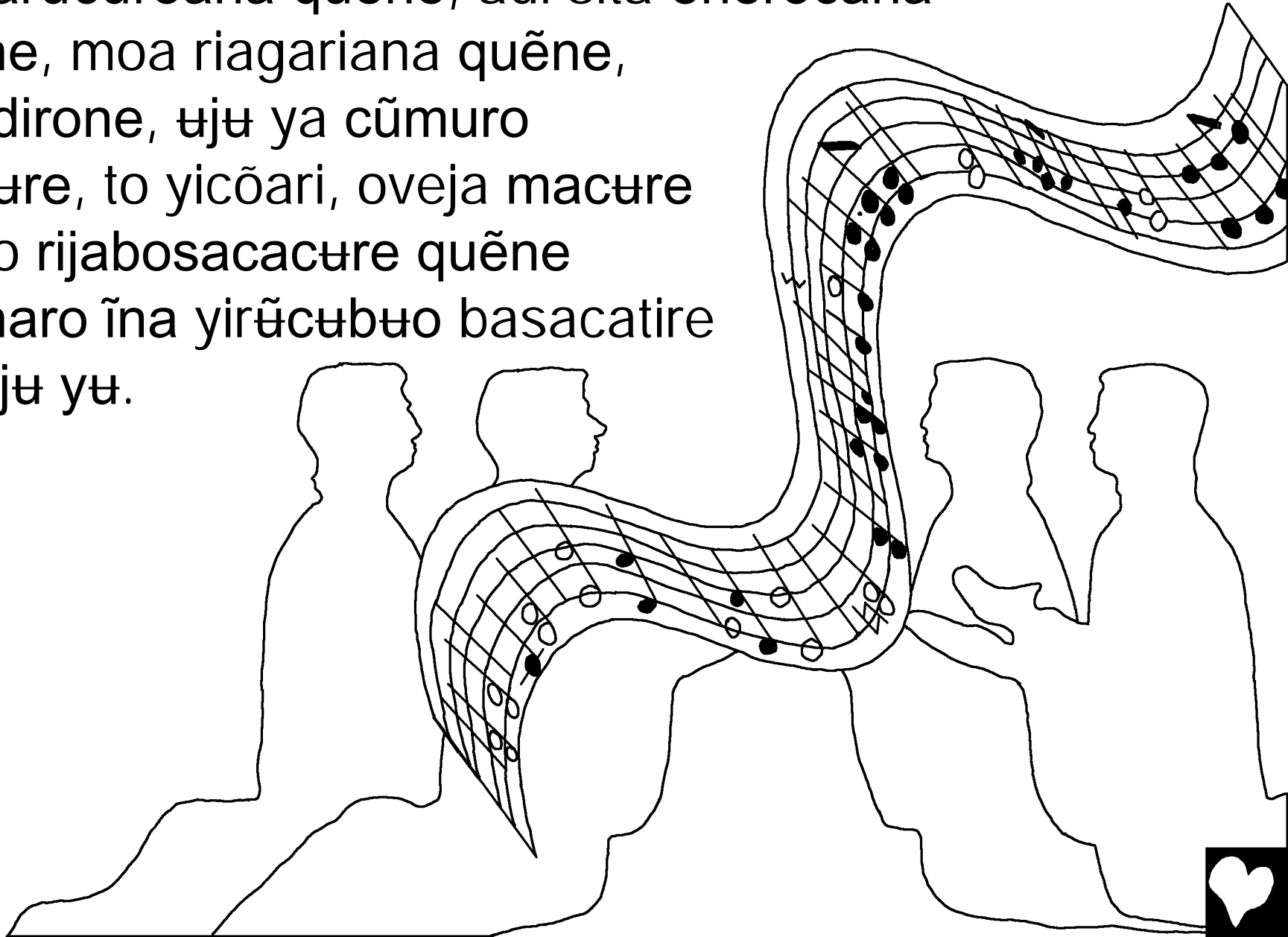

Ado bajiro ñare yibasacama: —Ado bajiro bajirã m̃a  
ñajare, quẽnaro m̃are yirũc̃b̃o variquẽnarũgũroti  
ñaja: Rẽtoro ñamasurã, rẽtoro  
quẽnarã ñaja m̃a. To bajicõari,  
rẽtoro masirã ñaja m̃a. To  
bajirã m̃a ñajare, m̃are  
quẽnaro yirũc̃b̃o  
variquẽnacõa  
ñaroti ñaja  
—yibasacama.

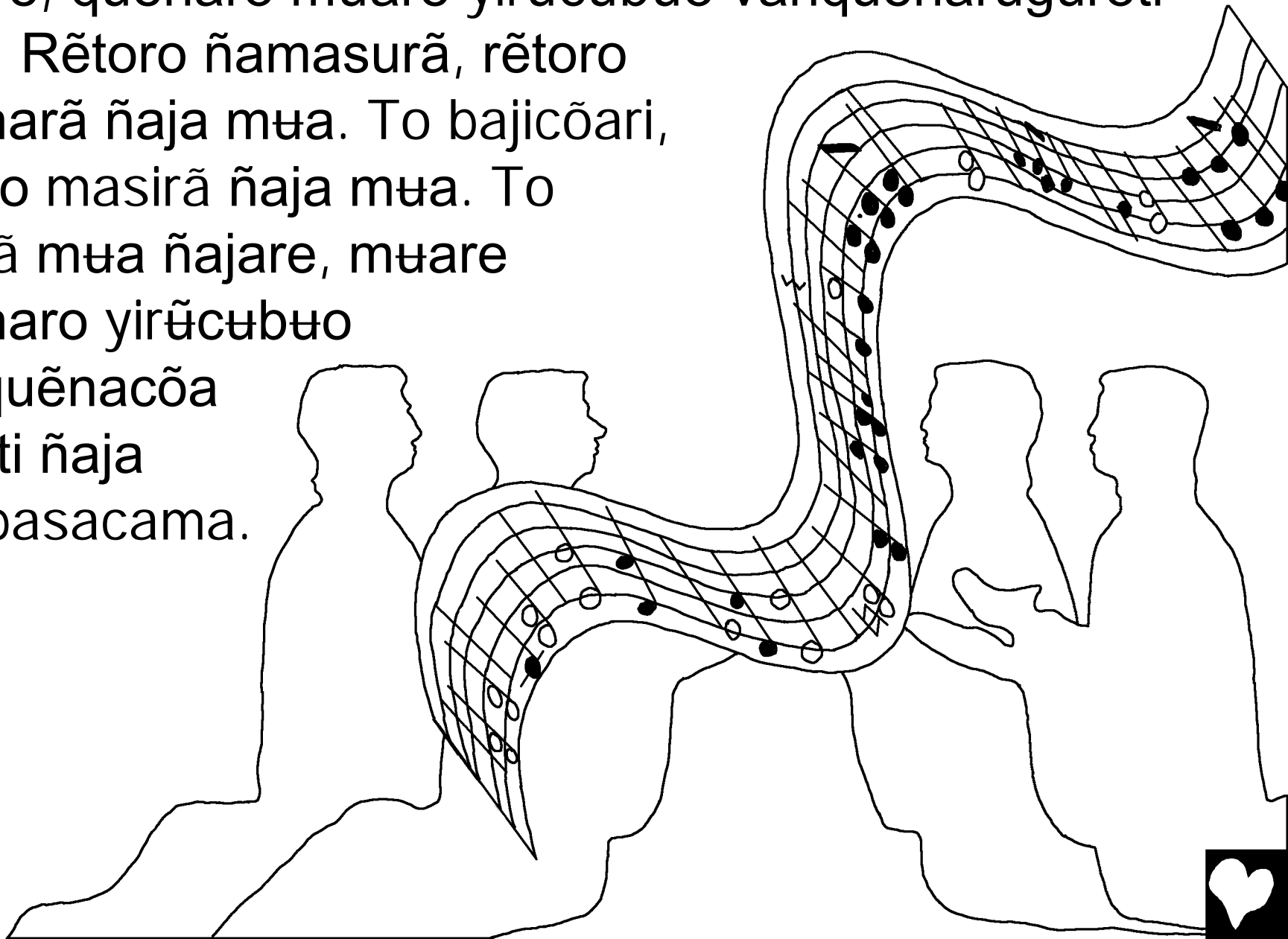

Quēnase rīne ĩna yirimaca, mame quēnoria maca  
Jerusalén vāme cęti maca ti rujiadore ĩacaję yę. Dios ĩ  
ņarojęne rujiadicaję ti maca. Rōmio āmosiagoago  
quēnase sudi so sãñayuriarore bajiro quēnari maca  
ņacaję.

Ti macare  
quēnoņumi  
Dios, ĩ tųję ĩ  
yarā, masa mani  
ejarotire yigę.

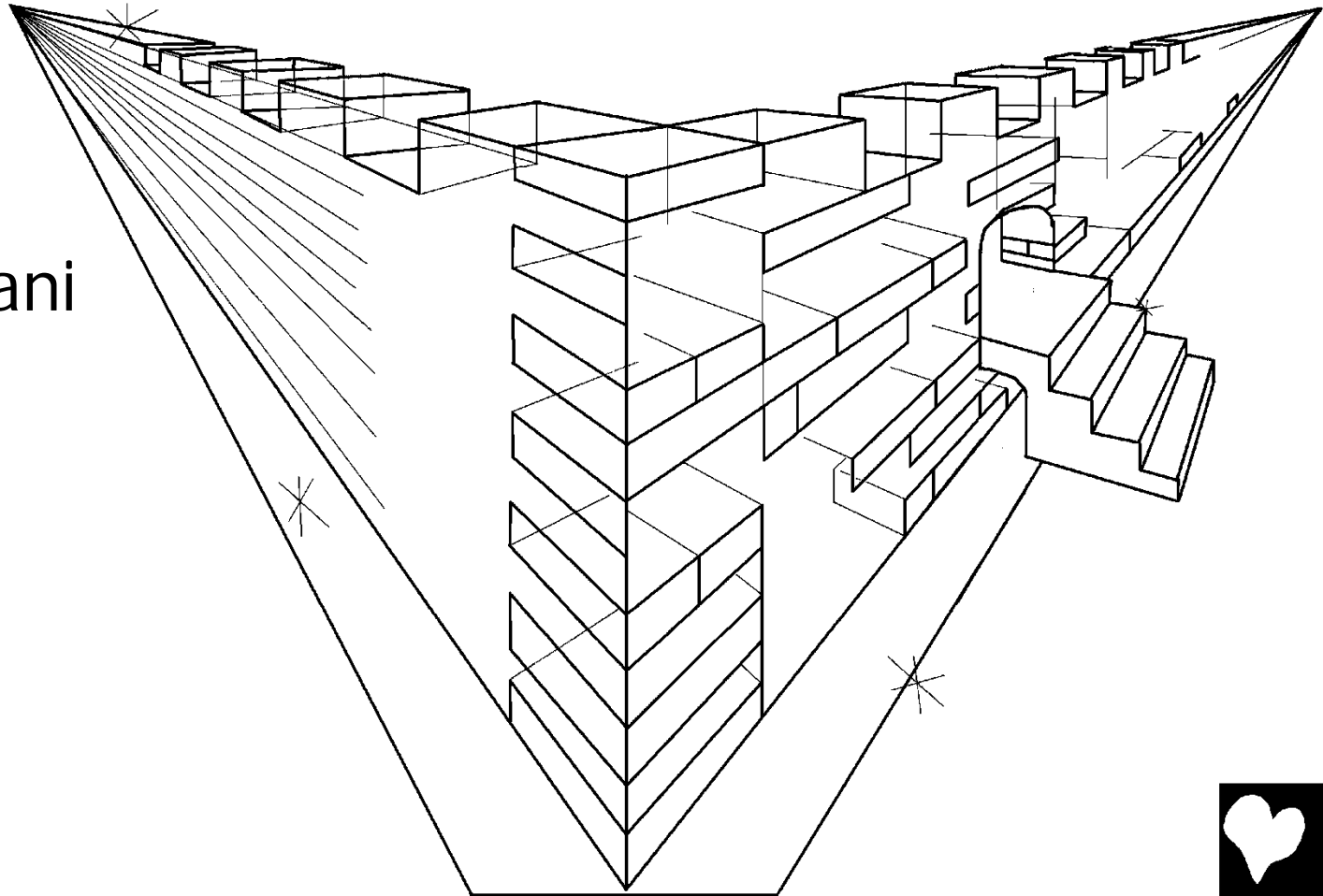

To bajiro ti bajirone, rotigɛ ĩ rujiri cūmuro ado bajise  
ruyugoaro ocaruyucajɛ: —Ĩaña. Masa rāca ñaami Dios.  
To bajiri, “Õ vecajɛ ñagũmi Dios” yire maja. ĩna rācane  
ñacõa ñarũgũrɛcɛmi. To bajicõari, masa  
quẽne ĩ yarã ñacõa ñarũgũrɛarãma.

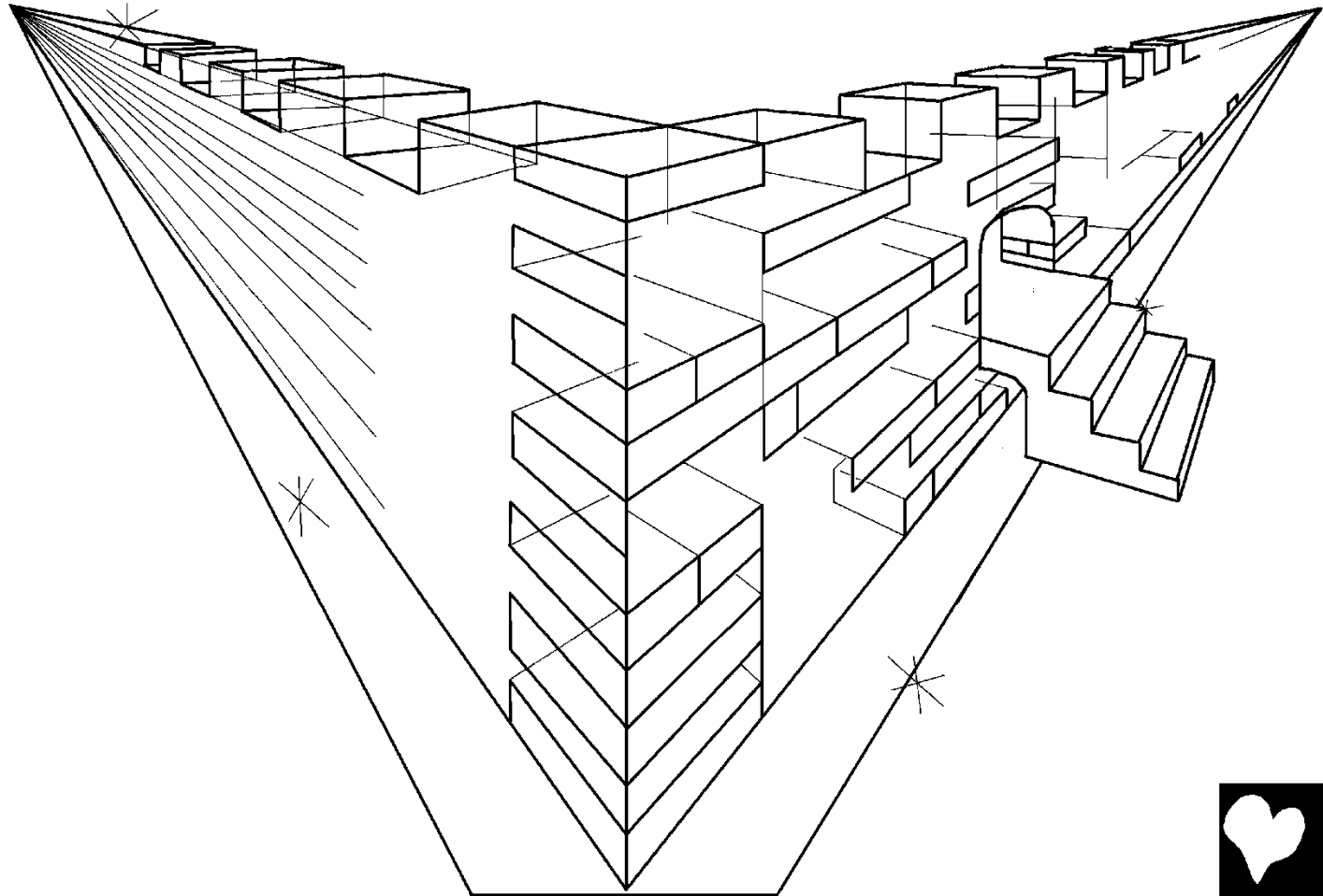

Tire yure ĩ ĩoro bero, quēna riaga oco ĩeri maniya  
catirũgũrotiayere oco cętiyare yure ĩocami ángel. Tiya,  
ĩeri mani botise oco cęticõari, ĩo sojeri ĩarētoburiarore  
bajiro quēnaro ruyurisa ñacaję tiya. Dios, rotigę ĩ rujiri  
cũmuroję, to yicõari, oveja macęre bajiro rijabosacacę,  
rotigę ĩ rujiri cũmuroję jode cęticaję tiya riaga.



To bajicõari, Dios ã ñarimaca ti ñajare, ã bususe rãca busucajã ti maca. To bajicõari, oveja macãre bajiro rijabosacacã ãre bajirone ã busurẽmojare, ãmãagã muiju ã bususe, ñamiagã ã bususe quẽne bojabeticaajã ti maca.

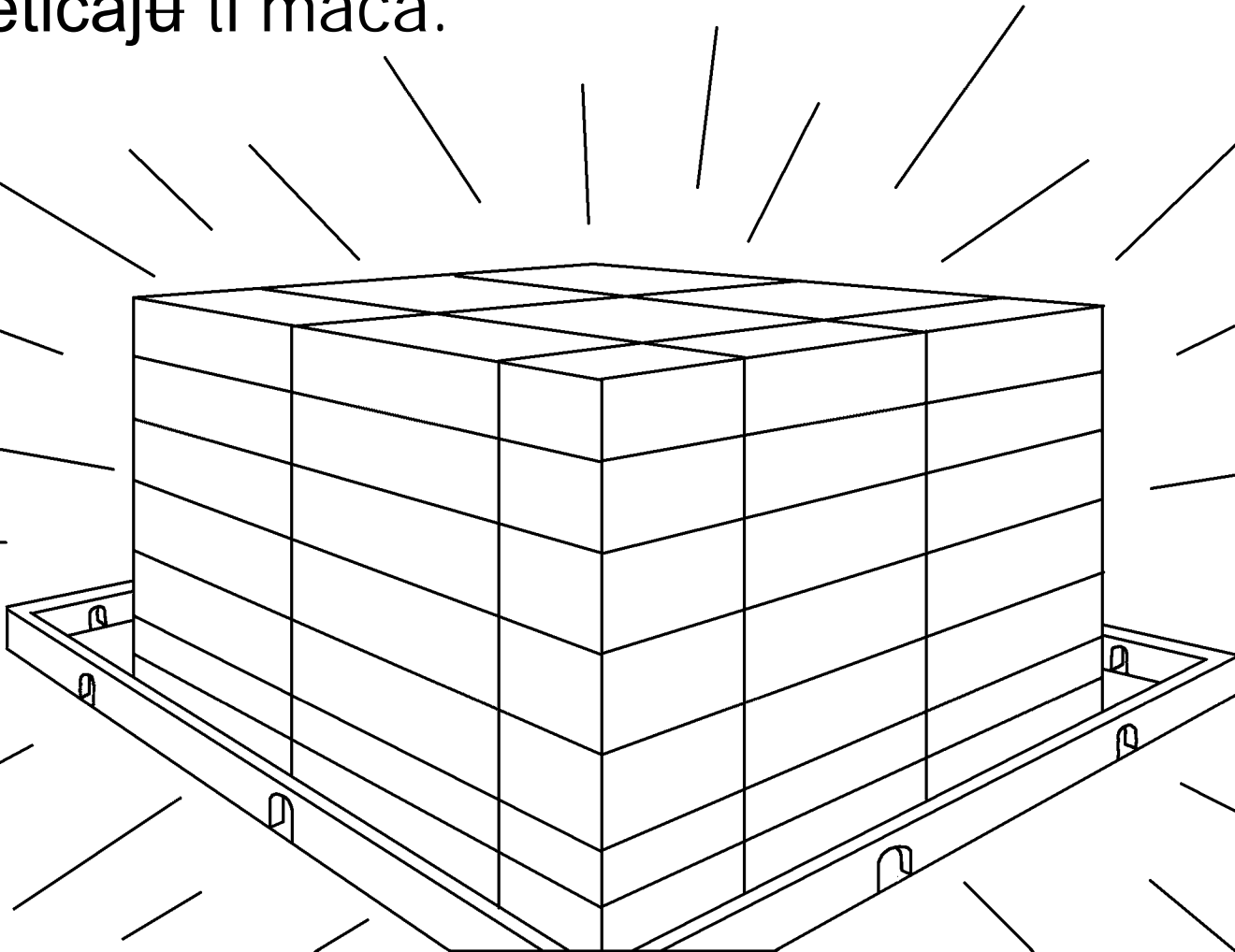

To bajicõari, —Dios ã ãatese, rojosere  
juavabetir̃arãma ti macaj̃re.

Rojose yirã, socarimasa quẽne,

ti macare sãjabetir̃arãma

ĩna quẽne —yigoticami

ãngel. —Oveja mac̃re

bajiro rijabosacac̃

yatutij̃, “Ado cõro

ñaaama ỹ rãca

ñarũgũrona” yiucatu

ecoriarã rĩne

sãjamasir̃arãma

—yigoticami ãngel.



Diorāca ñacōa ñarūgūrona ñna  
ñajare, bajireare, sətiritire,  
otire, jūnise, sarese, vūase ñna  
tām̄oboare jediro manir̄aroja.  
To bajiri, variquēnarūgūr̄arāma  
ñna. Tir̄m̄j̄ bajiboacati  
ti rētojedicōajare, to  
bajiroj̄a bajir̄aroja —yi  
osaruysaj̄, ō vecaj̄.



Ti macaj# Dios ĩ ĩatese maniroti ñacaj#. Ñajediro  
quēnase rīne ñarũgũroti ñacaj#. Ti macaj# Dios, to  
yicōari, oveja mac#re bajiro rijabosacac# rāca  
rotirā ĩna rujiri cūmuro  
ñaroti ñacaj#.



Ti macana jediro Dios ĩ bojasere yirã ĩre rũcũbũrona  
ñacama. Adi macarũcũrojũ Diore ĩabetirũgũriarã  
ñaboarine, tojũrema ĩre ĩarona ñacama. To yicõari,  
Dios vãme ĩna riovecarijũre  
ucatu ecorona  
ñacama.



Adi macarucuro bajireariarã, tudicaticõari tojũ rujigũ  
tũre ãna ñasere ãacajũ yũ. Ñamasurã, ñamasumena  
quẽne ñacama. To ãna ñarone, paperatutiri jãna  
ecocajũ. Titutirijũ masa jediro ãna yire ucature ñacajũ.  
To bajiri, tire ãacõari, “To bajiro yicana  
ñari, quẽnase bũjarã, rojose  
tãmũorã, bajirũarãja”  
bajireariarãre ãnare  
yicami to rujigũ.  
To yicõari, “Ado  
cõro ñaama yũ  
rãca ñarũgũrona” ã  
yiucaturiatuti quẽne  
jãna ecocajũ.

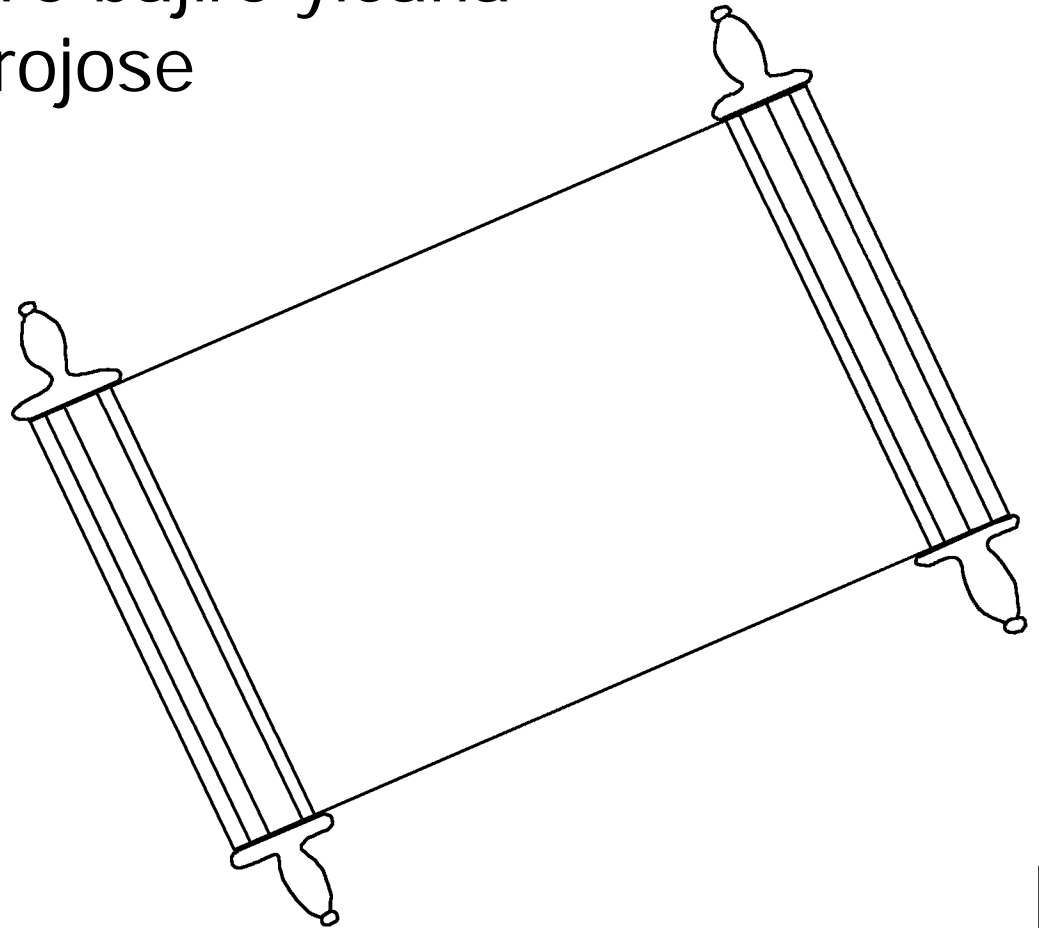

Tiję bero, adi macaręcęroaye, rojose mani tãmęose,  
rijaye jediro juacõari, azufre vãme cętise ĩjęri jeameję  
tire reajeocõacami Dios. To ĩ yijare, ĩ rãca ñarũgũrona,  
jęaji rijarona me ñacama. To ĩ yiro bero, "Ado cõro  
ñaama yę rãca ñarũgũrona" ĩ  
yiucabetiriarãre quęne  
juacõari, azufre vãme  
cętise ĩjęri jeameję  
ĩnare reacami Dios.

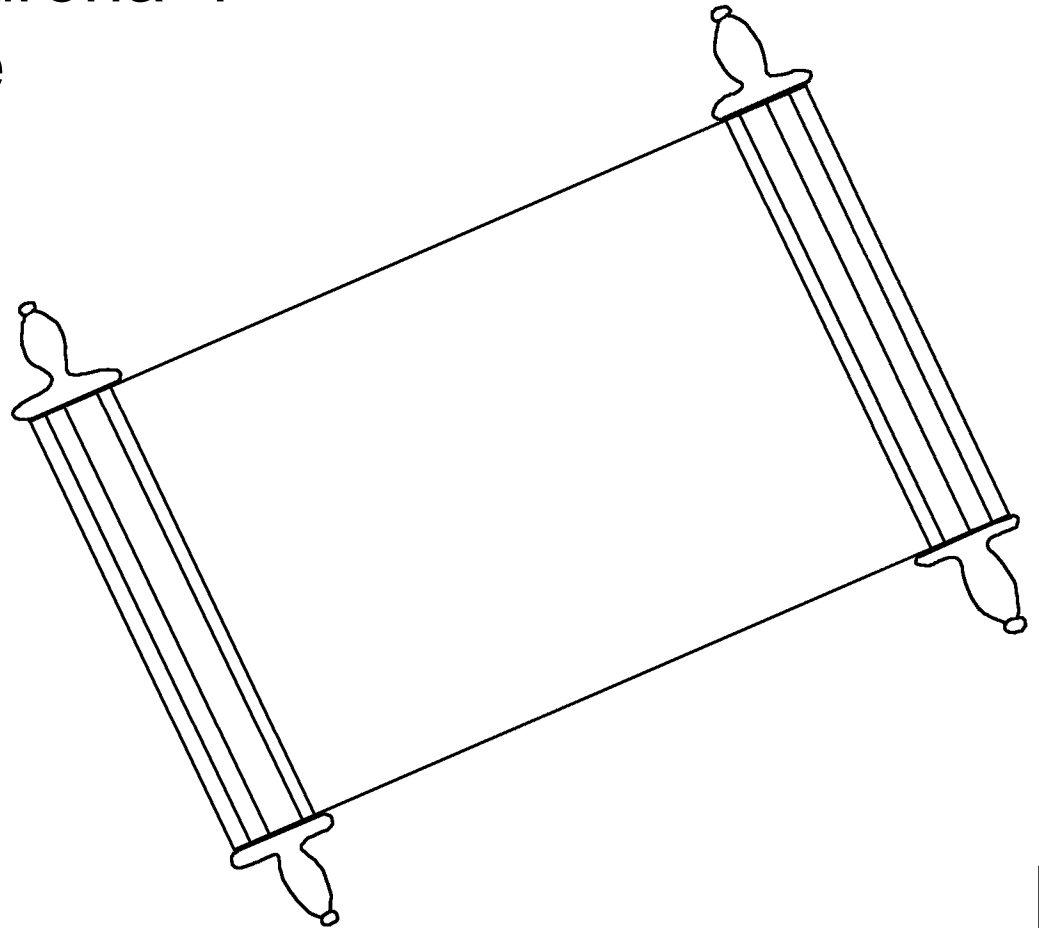

Oveja macure bajiro rijabosacacure ajitirũnrã ñari, to bajicõari, mani rãcagũ Esp'iritu Santo quẽne, ado bajiro Jesúre sēniaja mani: —Yua tũjũ vayá quẽna —ĩre yaja mani. Gãjerã adi queti yũ ucasere ajirã quẽne, —Yua tũjũ vayá —Jesúre yirũarãma.

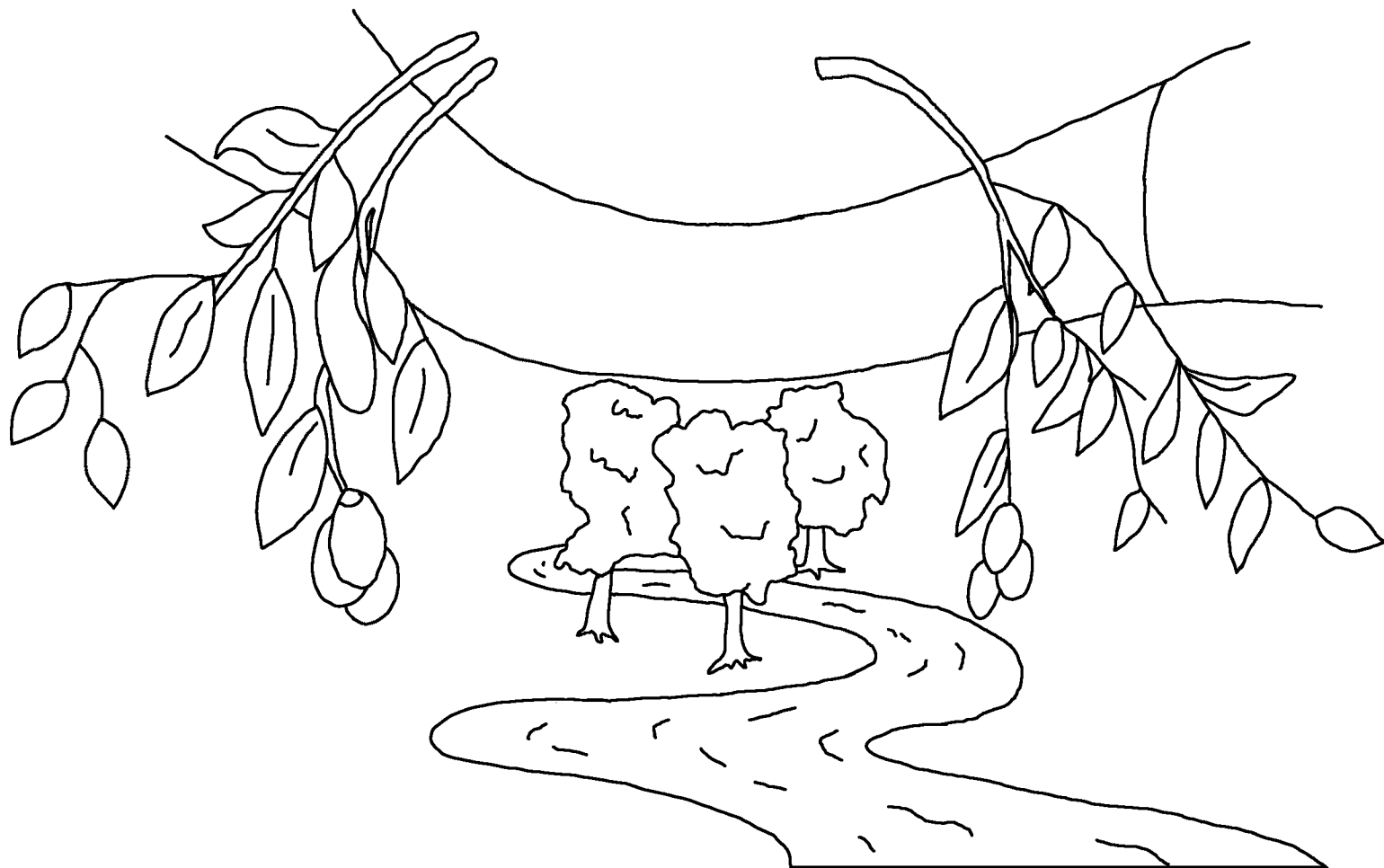

Jesújua quêne, —Yure sēniña —yigumi, ãre  
masiruarãre. Buto oco idiruarãre bajiro ãre masiruarã,  
ãre ãna sēnijama, “ãna rijato berojua tudirijabeticõato”  
yigui, Dios ã catisere ãnare ãsirucumi. Dios ã bojabetire  
mani yiboajaquêne, rojose mani yisere manire vaja  
yibosayumi  
Jesús.



—Ñajediro masare  
maimasucõagũ ñari, ã macᄁ  
sĩgũne ñagũre ãre cõañumi Dios,  
“Masare rijabosato” yigᄁ.



To bajiro ã yire ñajare,  
"Jesucristo ã bajirocare s̄orine ȳre  
ĩavariquẽnacõari, quẽnaro yir̄c̄mi  
Dios" yit̄oĩarãma, ãna rijato beroj̄  
"Tudirijabeticõato" yiḡ, Dios ã  
catisere ã ãsiriarã  
ñarãma.



## Romanos 3:23

Ado bajiro bajaiaja ti, Dios quēnaro manire ã yise: Dios ã rotimasire ñaro cōrone c̄dijeog̃ mag̃mi. To bajiboarine mani jedirore maig̃ ñari, “Masa rojose ñna yise vaja ñnare vaja yibosaaya” yig̃, ã mac̄re cōañumi Dios. ã mac̄ ã rijabosare ti ñajare, rojose mani yisere manire masirioyumi Dios, Cristore ajitir̃ñr̃ãre. To yig̃ ñari, “Ñie rojose mana ñaama”, manire yĩaami Dios yuja. To bajiro bajaiaja jud'io masare, jud'io masa me ñarãre quēne.

## Romanos 6:23

To bajiri, masa rojose mani yise vaja mani rijato beroj̃ rojose tãm̄ot̄jabetiriaroj̃ varoti ñaja. To bajiboarine, Jesús yarã mani ñajama, rojose mani yise vaja, mani vaja yibetiboajaquēne, mani rijato beroj̃ “Tudirijabeticōato” yig̃, ã catisere manire ãsiami Dios.



## Hebreos 9:27

Mani jediro cojojine bajirearona ñaja mani. Mani bajirearo bero, ï tuj̃ mani ejato, rojose yirãre, to yicõari quẽnase yirãre ïabeser̃c̃mi Dios.

## Efesios 2:8,9

M̃a masune, "Quẽnaro yirã ñaja ỹa" m̃a yiro me, ï bojarore bajiro m̃are yig̃ yiyumi Dios. To bajiri, "Quẽnaro manire yibosayumi Dios" m̃a yit̃oĩajare, rojose tãm̃ot̃ujabetiriaroj̃ m̃a vaborotire m̃are yirẽtobosayumi. Cristo ï yirẽtobosare ñajare, "Quẽnaro yirã ñari, Dios tuj̃ ñar̃arãja ỹa", yiroti me ñaja.

## Romanos 10:9,10

"Jesús ï rijacoaboajaquẽne, ïre tudicatioyumi Dios" yit̃oĩacõari, "Jesús ñaami mani ãj̃" m̃a yigotijama, rojose tãm̃ot̃ujabetiriaroj̃ mani vaborotire manire yirẽtobosar̃c̃mi Dios, yigotimasiorũgũaja ỹa.



Tire ñnare yña gotimasiojama, “Rojose mana ñaama” ñnare yĩacõari, rojose tãm̄ot̄ujabetiriaroju ñna vaborotire ñnare yirẽtobosar̄c̄umi Dios yirã, ñnare gotimasiorũgũaja.

San Juan 3:16,17

—Ñajediro masare maimasucõagũ ñari, ñ mac̄ s̄igũne ñagũre ñre cõañumi Dios, “Masare rijabosato” yiḡ. To bajiro ñ yire ñajare, “Jesucristo ñ bajirocare s̄orine yñre ñavariquẽnacõari, quẽnaro yir̄c̄umi Dios” yit̄oĩarãma, ñna rijato beroju “Tudirijabeticõato” yiḡ, Dios ñ catisere ñ ñsiriarã ñarãma. Adi macar̄c̄uroanare, “Rojose ñna yise vaja rojose ñnare yato” yiḡ me, ñ mac̄re cõañumi Dios. Ado bajirojña yiyumi. “M̄re ajitir̄ñ̄rona ñna rijato beroju, rojose tãm̄ot̄ujabetiriaroju ñna vaborotire ñnare yirẽtobosar̄c̄uja m̄” yiḡ, ñ mac̄re cõañumi Dios.



## 1 San Juan 5:11-13

Ado bajiro mani masirotire bojami Dios: "Socase me ñañuja Dios ñ yire" yituoñarã mani ñajare, "Mani rijato berojɁ mani catirotire ñ catisere manire ñsiñumi Dios" mani yimasisere bojami Dios. No bojarã ñ macɁre ajitirũnrã, ñna rijato berojɁ ñna catirotire Dios ñ catisere ñsiecoriarã ñarãma. ñ macɁ yere ajiterãma, Dios ñ catisere ñsiecomena ñaama." "Mani rijato berojɁ Dios tɁjɁ mani catirotire Dios ñ catisere ñ ñsiriarã ñaja mani' yimasiato" yigɁ, Dios macɁre ajitirũnrãre, adi papera mɁare ucacõaja yɁ.



San Juan 14; 2 Corintios 5;  
Apocalipsis. 4, 21, 22

Storyline by: Edward D. Hughes

Illustrated by: Lazarus  
and Alastair Paterson

Adapted by: Sarah S.

Barasana-Eduria Bible (bsn) © 2010, Wycliffe Bible  
Translators, Inc. All rights reserved.

<https://www.bible.com/bible/571/MAT.1>

©2026 Bible for Children, Inc.

[www.M1914.org](http://www.M1914.org)

[www.bibleforchildren.org](http://www.bibleforchildren.org)

