

[www.BibleForChildren.org](http://www.BibleForChildren.org)



ዮሀንስ 14



ካርንከረ የሱስ፡ “የንታ ቡድና ዐይማጠራ፥ ሳብካ አመንከቴ፥ እንከረ አመንከቴ፥  
እስታ ባቤንታ ኤሪ በድ ዶቅንትታ ካሪ ዶቅዴ፥ ኩን ማታከሰናና እታ የካንታ  
ኬዝድትዶቆ የ ዶቅተርንደትም ካሪ ግግስካንታ አይድቴ። አይስቶ ካሪ የካንታ እ  
ኡርሳንደታ ቡር እ ዶቅድንደታር የ ዶቅተርንግንዳ ካርንካ ዐይድስቶ የም እዝደር  
ተይ አይድቴ።”

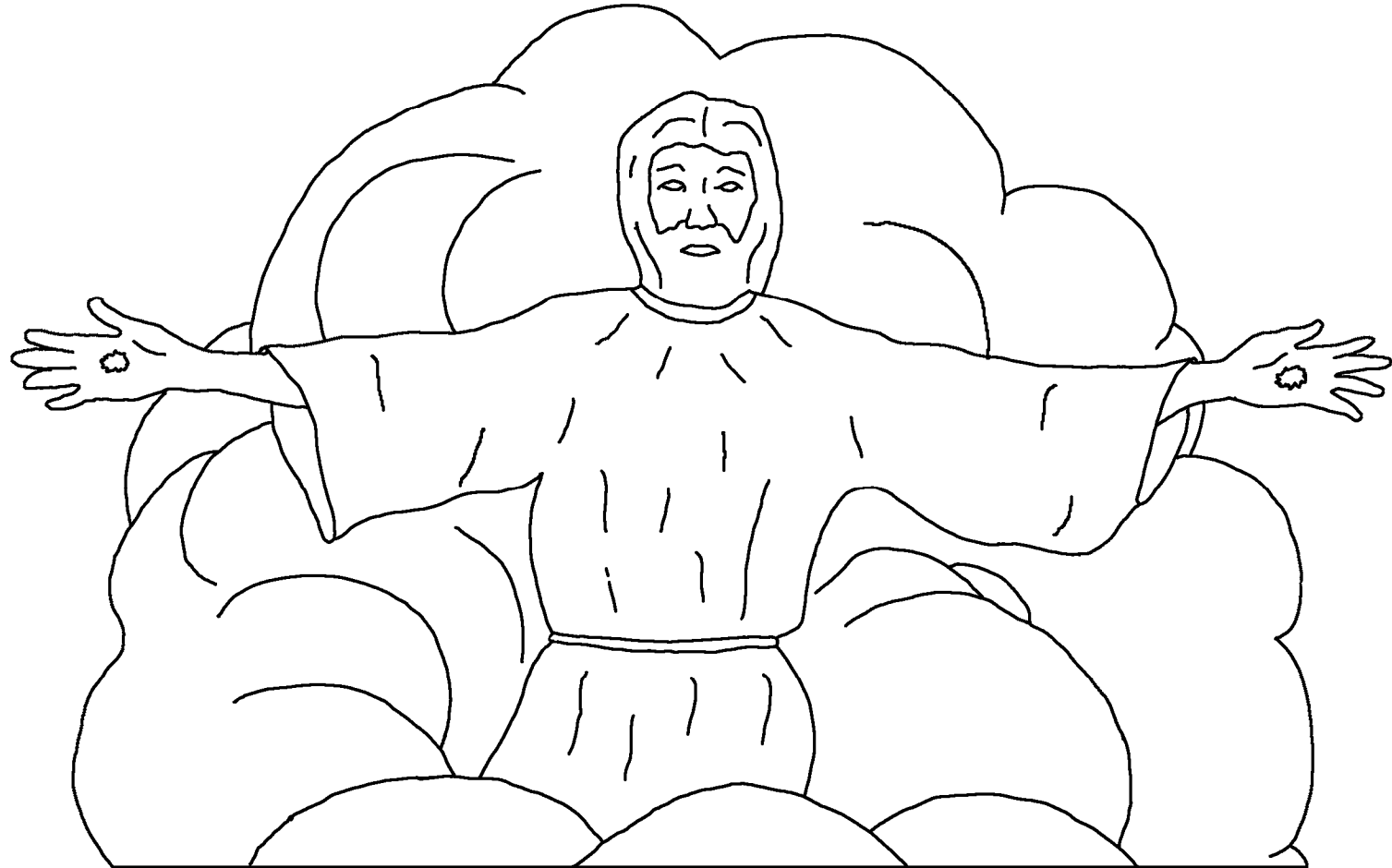

የሱሰን ማጠንምኬ ክታ ባንቸምንታ ኮትኮግንደረ ዳንዳእንም  
የንካ ክክን ካስምድባብ እታ የንታ እስመን የሀንስ ሳብታ  
ቃለኬ የሱሰታ ማርካትቼንጎካ ፍጥሞ ጋይምድን

ሎቀታ ምክናር ዶቅድን  
ደንንዘን ዐቃቴ።



ሳነካ ቱምቱም ጋየርቶ አያናር፤ ይና ጭላር ባንቸምንከስ ዶቅድን ጎንገን ሰዳቴ፤  
ባንቸንከስ ዶቅድን ጎንገንዘን ዋልቃባብ ዶቅሰንካ ሰድቴ።

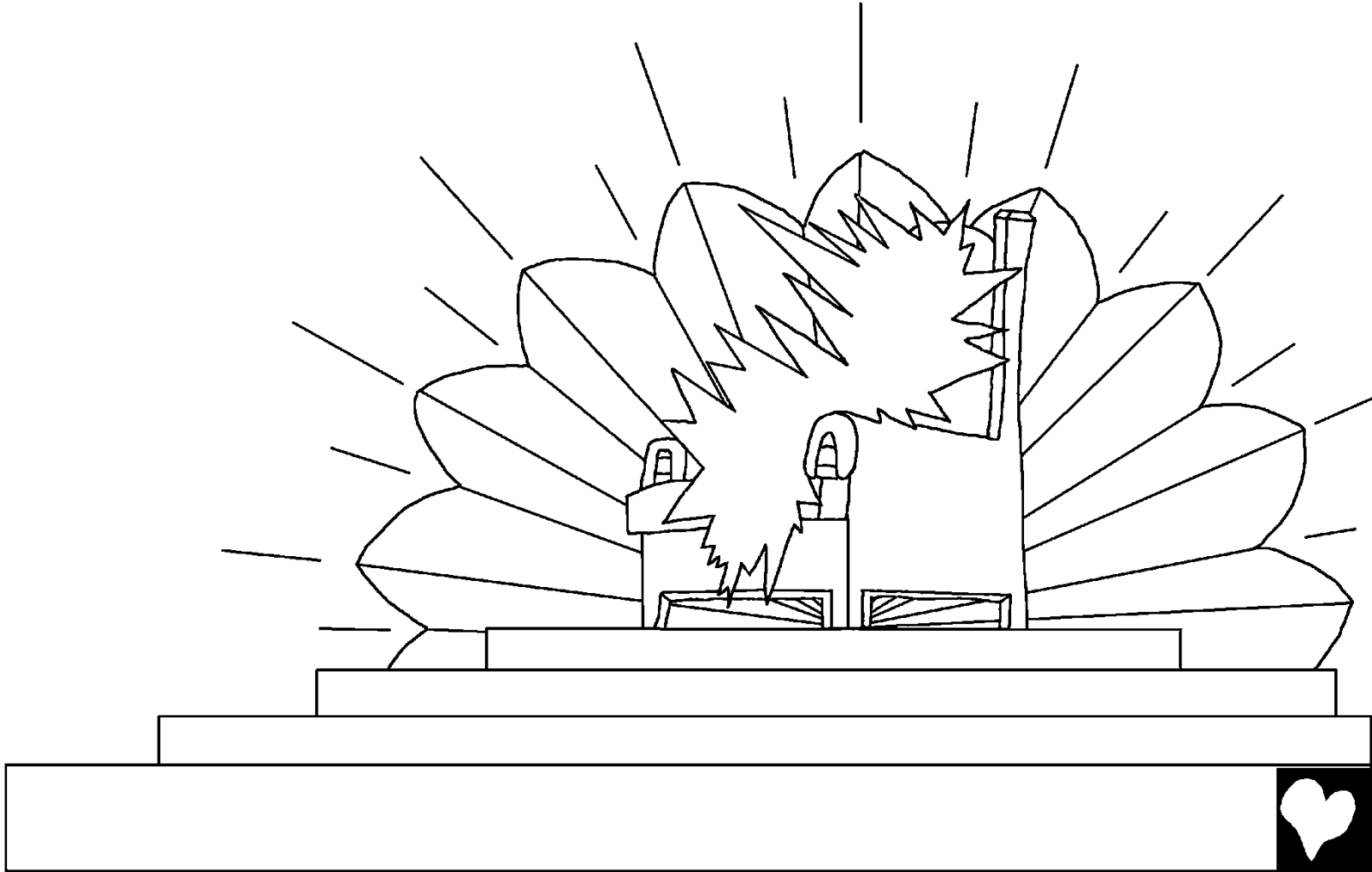

ጭለዘነረ ፍጨዘን፣ ፍጨታ ጎዖርኬ ባሀርናር፣ ከታዋረረ  
ፍዝርንከሰ ሙዳ “ባንቸምንከሰ ደቅድን ጎንገንዘን ደቅሰባብካንተኬ  
ቆለንካንተረ ጋለትኬ፣ ዴእሰካ፣ ቦንቼኬ  
ዎልቀካ ስለንክንደትዘንካ ስለንካ የለልታ  
ማታ!” ከት ጋይድንካ ኤሰርሳቴ።



ሳብካንታ ፋስምሳን ካተመና ክላ የሩሳሌም ይንታ ክእስንካንታ ሰክስምሳን  
እስንደትግንዳ ግግምሶ ጭላር ሳብደርንካ ኮት ፀንቸርድንካ ሰድቴ። “ይና!  
ሳብታ ገቸንተና ኤድንከስካ ክክኔ። ከትከረ ክክን ኖ ዶቅተሬ። ከተረ ክታ ዎርሳ  
ማተረኬ። ሳብ ይንታ ማታርንካ ከትካ ክክን ማተረ። ኬታ ጮይሰረ ኖ ማተረ።  
ኬታ ኤርመንመረ

ሙዳ ኬታ

አፍንዘንካ ፀጭተረ።  
ኤና እሪ ሪንከስ ሙዳ  
ስገዳንካንታ ደእ አነረ  
ሞርእ አነረ ኤፍ አነረ  
ማጥር ይና ኮዘንካ አስ  
ዶቃዬ” ኩነረ ጋይድንዳ  
አንድር ኡፍስ ባንቸንታዶቅንት  
ጎንገንዘንካ ዉድንካ ኤሰርሰቴ።

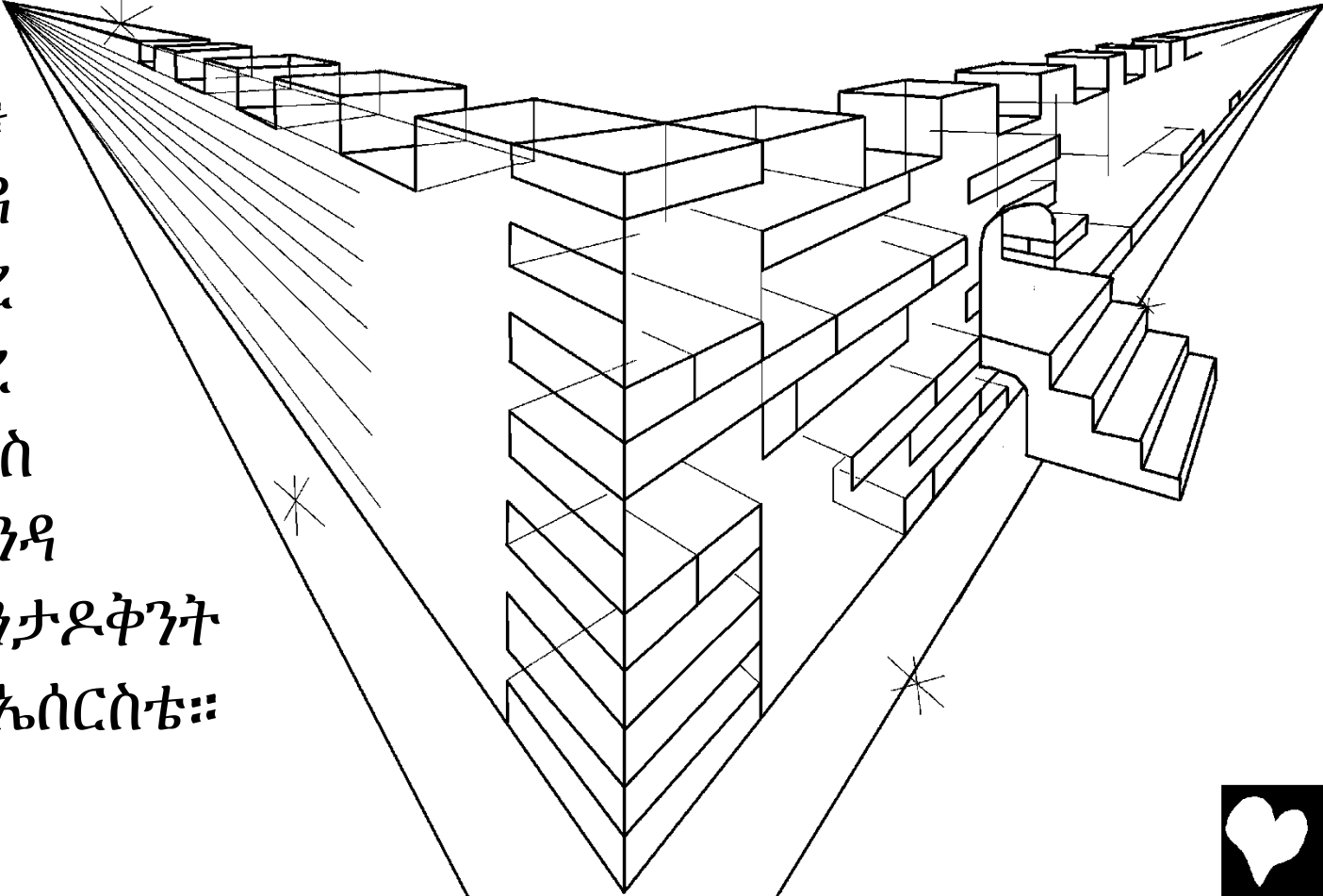

ኮታ ቡር ክታይንቸና ሳብዘንኬ ቆለንንታ ባንቸም ጎንጎንዘንካ ዉድንደትም  
ማስታትግንዳ ሳግዘድንደትም ጭለጭል ጋይሳን ሙርግድንዳ ደቅንት ሎቀን  
እም ሰቸሴ፥ ቃሪንመረ የድሶ ሳኦ ስላካንታ ክትም ዘክሴ፥ ኮነረ ቃሪና ዳብሎስ  
እነረ ሰጣን ጋይምድባብ ኤና እሪ ጉንኔ።

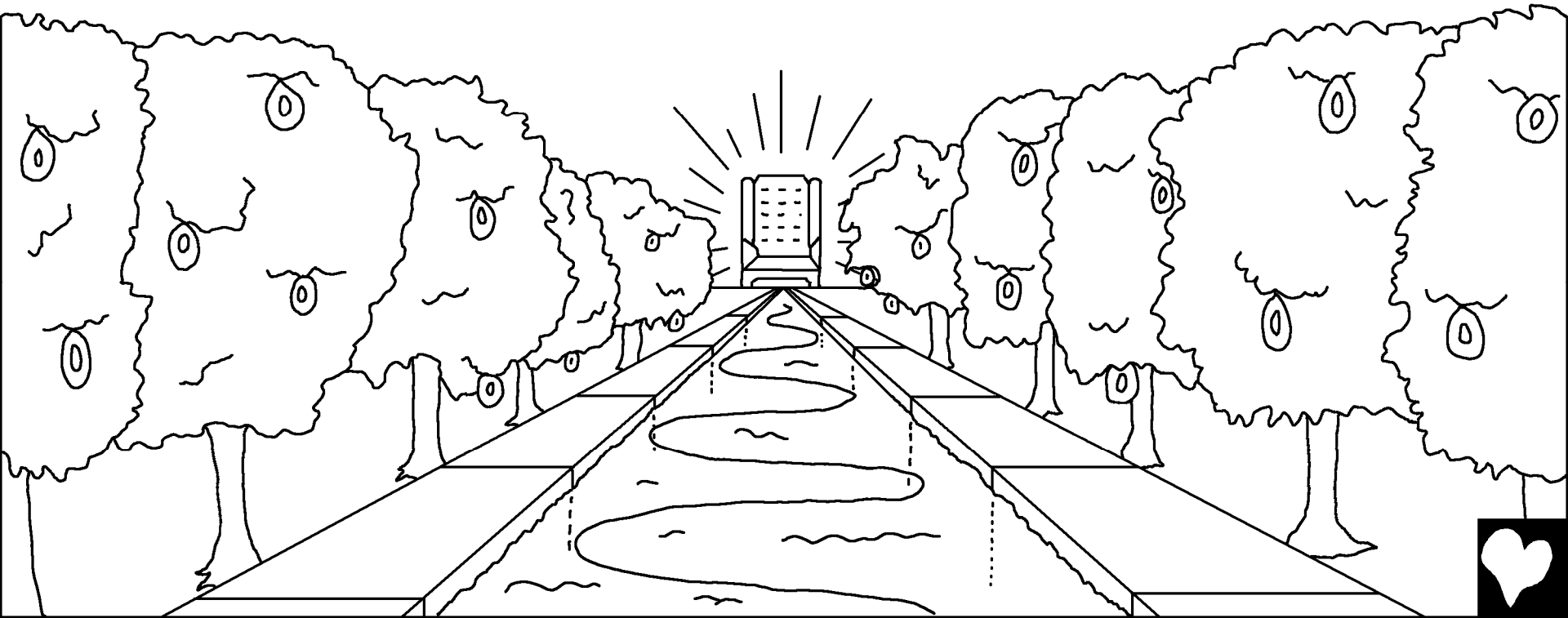

ሳብታ ቦንቼና ኮትካንታ ሳግዝድንካንተኬ ቆለንና ኮትካንታ ሳግዝድንክል ኮት  
ካተመንካንታ ዐይነረ ማታ ኦርፈን ኮትካንታ ከት ሳግዝድንግንዳ ዝግሳዩ።

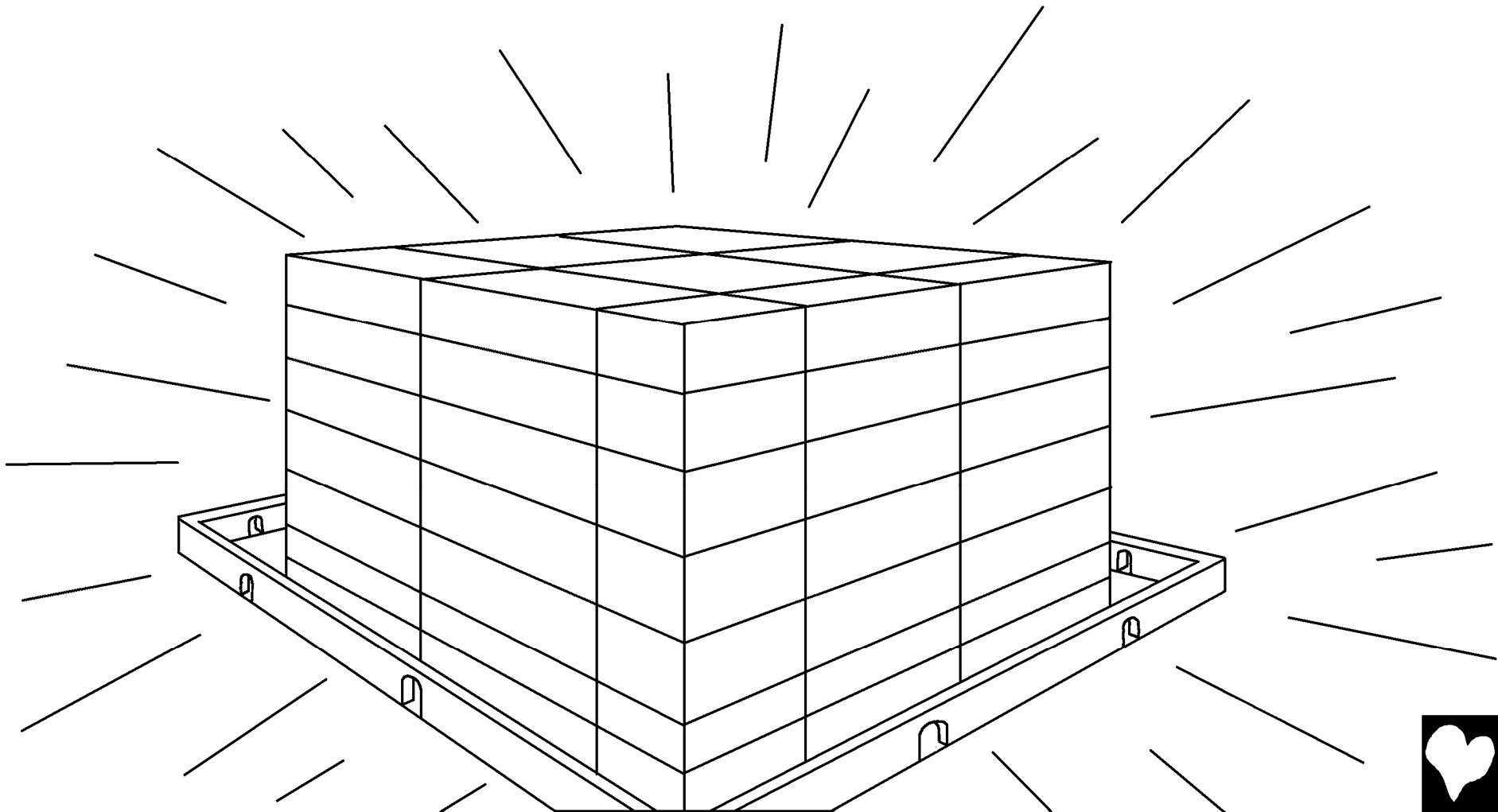

ይንኤርዝድን ሪ ማቻንዳ ቦድሶ ኮታር አርዳዬ፣ ቱና ማቻን ሪም  
ይድባብኬ ማልትንም ኬዝድባብ ቦድሶ ኮታር አርዳክዬ፣ ኮታር  
አርድባብከሰረ ኬታ ላምና ዶቅንት  
ማጻፍና ጻፍምስባብከሰ ዐክዬ።



“ኬታ ኤርመንመረ ሙዳ ኬታ አፍንዘንካ  
ዐጭተረ፣ ኤና እሪ ሪንከሰ ሙዳ ሰገዳንካንታ ደእ  
አነረ ሞርእ አነረ ኤፍ አነረ ማጥር ይና ኮዘንካ ኦሰ  
ዶቃዬ” ኩነረ ጋይድንዳ አንድር ኡፍሰ ባንቸንታ  
ዶቅንት ጎንገንዘንካ ወድንካ ኤሰርሱቴ።



ይና ኮዘንካ ኦስ ፀረሰነረ ባድና ዶቅተራክዬ፥ ሳብተኬ ቆለንንታ ባንቸም ጎንገና ካተመንኮታር ማተረ፥ ክታ ፍክሰንባብከሰረ ክትም ጎይንደኬ፥ ክታ ባለንመረ ሰደኬ፥ ክታ ላምነረ ኬታ ባለንዘን ጸፍምተረ።



ደእስባብ መረንከስምኬ ባከንከስም ባንቸምንከስታ ዶቅንት ጎንገንታ እሪ ከት  
ዎእስንካ ሰድቴ፥ ማጻፍንከሰረ ፎቸምሰኬ፥ ዶቅንት ማጻፍ ማቻንዳ ኣብ ማጻፈረ  
ፎቸምሴ፥ ደእስባብከሰረ ማጻፍንከሳር ኬታ ፍክስና ጻፍምሶ ፀፈርሳንከካ  
ፍርደንም ተየኬ፥ ባሀርነረ ይንታ ዋር ደእሶ ዶቅድባብከስም ወቸሴ፥ ደእኬ  
ደእስባብከስ ዶቅድን ጎርነረ ከታር ፀቅባብ  
ደእስባብከስም እምሰኬ፥ ዋልቃ ዋልቃ  
ኤድንከሰረ ይንታ ፍክስንግንዳ  
ፍርደን ተዬ። ላምና ከታ  
ዶቅንት ማጻፍናር ጻፍምሶ  
ፀፈራክባብ መደና ኖሀ  
ባሀርናር ኣይትምሴ።

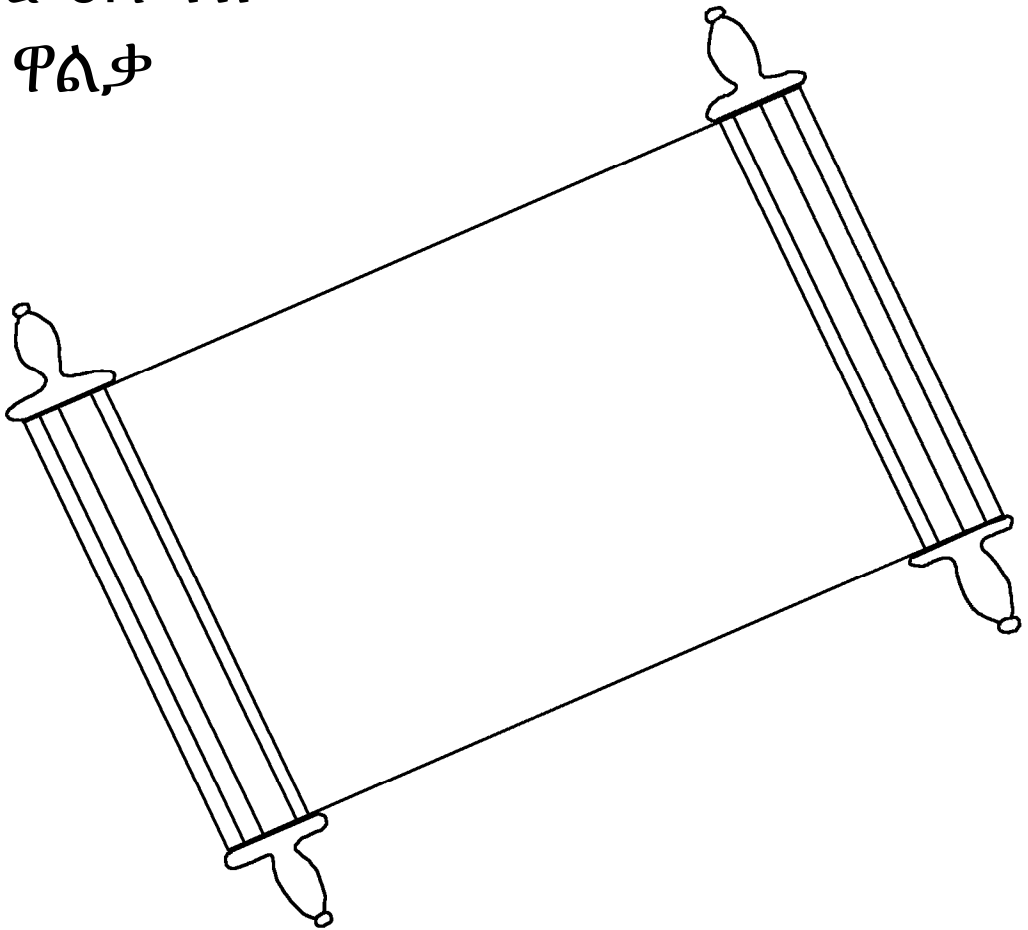

ክታ አያንንኬ እሰነረ “ኮሬ!” ጋይደኬ፥ ኤሰርድባበረ “ኮሬ!” ክት ጋያ፥  
ዎቼርሰባበረ ፀዳ፥ ዝግዝባበረ ደቅንት ሎቀን ፀረሰነረ ናክካይሳ  
ዉቸኩን ክት ዎጫ።



ክትካ አሜንድባብ ሙዳ ስለንካ ደቅንት ደቅድንግንዳ  
ዳት ከት ካይዳክንግንዳ ሳብ ፍጫ ሙደን አንድር  
ሶልምሳንካንታ ዋልቃ ይንታ  
ይንቸንም እምሴ።



ሮማ 3:23 ኤድንከስ ሙደና ጎማ ፍክሴ፥ ሳብ ከትካንታ እምሳን ቦንቼና ከታዘንካ ካይቴ።

ሮማ 6:23 ጎመዘንካ ዐፈርድን ናክና ደእዬ፥ ሳብዘንካ እምምድን እምንተና ማቼ ዎንታ ጮይስን የሱስ ክርስቶስንካ ዐፈርድንዳ ስለንክንደታ ዶቅንትዬ።

ዕብራውያን 9:27 ኤድካንታ ዋልቃዱት ደእ ከትካንታ ጋይምቴ፥ ደእንታ ቡረረ ፍርዳ ከታዘን ዶቅዴ።

ኤፈሶን 2:8,9 የታ የ ኣቃንዳ ኣሜንካ ወቸ እምንተንጎኬ፥ ና ኮነረ ሳብታ እምንታ ዳት የንዘንካ ካዬ። ዐየነረ ጋይርዳክንግንዳ ኣቅንተንታ ወቸ እምንተና ዐፈርሳንዳ ከታ ፍክሰካ ካዬ።

ሮማ 10:9,10 የሱስ ጮይስ ማትንተን የስታ ኣፈንካ የስ ማርከርሰኬ ሳብ ከትም ደእያርንካ ኣምሳንደትመረ የስታ ቡዳርንካ የስ ኣሜንሴ ኣቅተራዬ። ኤድ ቡዳርንካ ይ ኣሜንሴ ጭልምዴ፥ ይንታ ኣፌከረ ይ ማርከርሴ ኣቅዴ፥



ዮሀንስ 3:16,17 “ከትካ አሜንድባብ ሙዳ ስለንካ ደቅንት ደቅድንግንዳ ዳት ከት ካይዳክንግንዳ ሳብ ፍጫ ሙደን አንድር ሶልምሳንካንታ ዋልቃ ይንታ ይንቸንም እምሴ። ሳብ ይንታ ይንቸን ፍጫሙደንዘን ከት አይቻንዳ፥ ፍጫ ሙደና ክታ ይንቸንካ አቅድንግንዳ ዳት ፍጫሙደንዘን ፋረድካንታ ካዬ።”

1 ዮሀንስ 5:11-13 ክታ ማርካትቼነረ ሳብ ስለንካ ደቅንተን ከት ዎካንታ እምሳንግንደኬ ኮነረ ደቅንትና ክታ ይንቹንካ ደቅድንደትም ማርከርድንዴ። ሳብታ ይንቸና ደቅድባብካንታ ደቅንት ደቅዴ። ሳብታ ይንቸና ካየንባብካንታ ማቼ ደቅንት ክታ ካዬ። የታ ሳብታ ይንቸንታ ላምንካ አመንድባብከስ ሙደና ስለንክንደታ ደቅንት የንታ ደቅድንዳ ማትንተን የ ኤስተርንግንዳ ኮም ሙዳ የካንታ ጻፍትቴ።



ዮሀንስ 14; 2 ቆርንቶስ 5; ለምላም 4, 21, 22

Storyline by: Edward D. Hughes

Illustrated by: Lazarus  
and Alastair Paterson

Adapted by: Sarah S.

Gayil Ethiopic NT (gyl) The Word for the World Ethiopia

<https://www.bible.com/bible/4130/MAT.1.GYLNTETH>

©2026 Bible for Children, Inc.

[www.M1914.org](http://www.M1914.org)

[www.bibleforchildren.org](http://www.bibleforchildren.org)

