

[www.BibleForChildren.org](http://www.BibleForChildren.org)

Joni 14

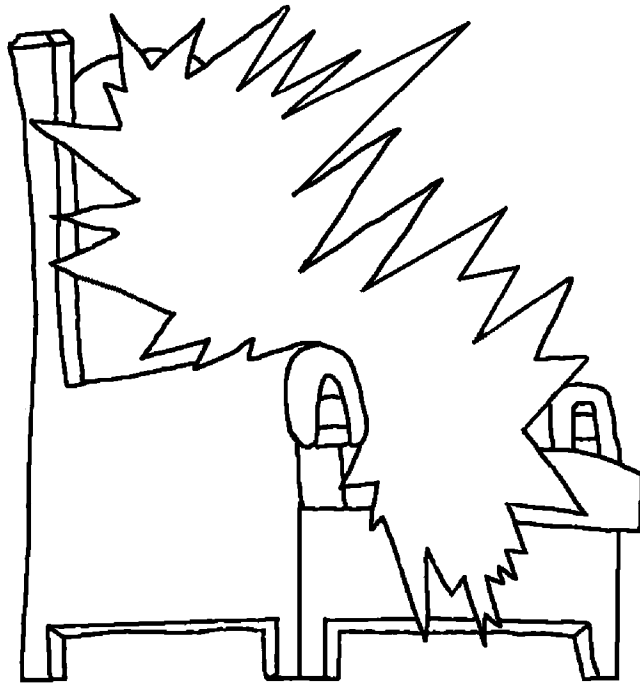

Yesu nkye, <<Kede dishiya ku e basi. Ku beigaskye nja Mirikisi; ku kwa beigaskye nja Ni. A siki gizi Adaa na laki ma nyowa; nde e ma yomu aba, da Ni gye ku. Na te de ni gyala anya sobon ku. A beyi de ni te gyala ku anya, Na zo de ni la ku te anya na, de kuma anya ni nja ni du.>>

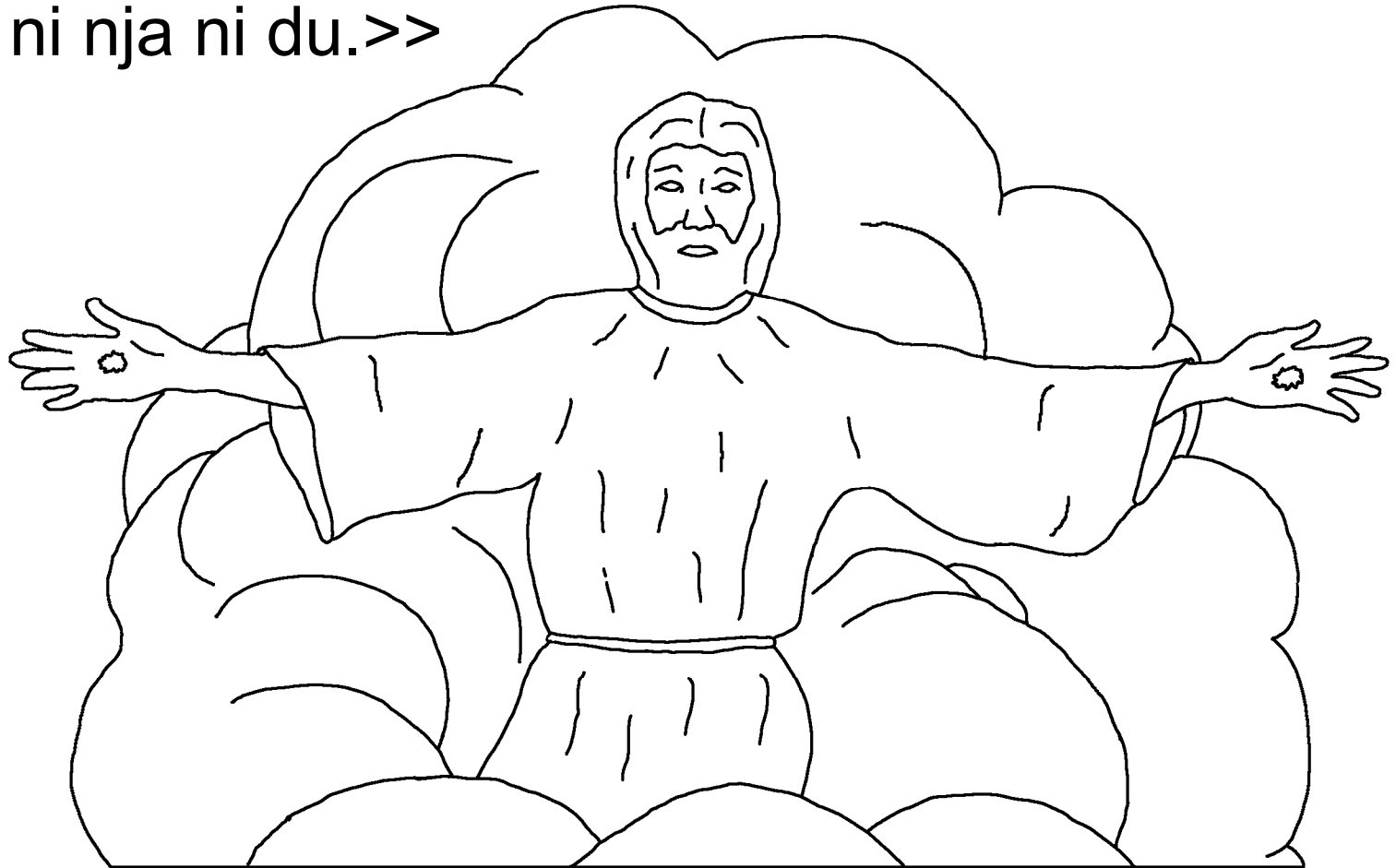

Eni ni ma, Yaaya, yayiwa ku, nsu biya Yesu Ni ma  
oboki anki nsu ankuri ni kadishiya a siki Genbeki  
ni worede ma nsu solota yi. Su la ni ta

Patmos geri de gyewe ni  
riki sobon ni ma beyi



manki kelima  
beta Mirikisi nja  
gaskye de  
Yesu pelesa.



Dandani se Aworo Mirikisi sonka a kiya naa. Anya ni a bisi nse da zunwa a kiya kingbolo solota.

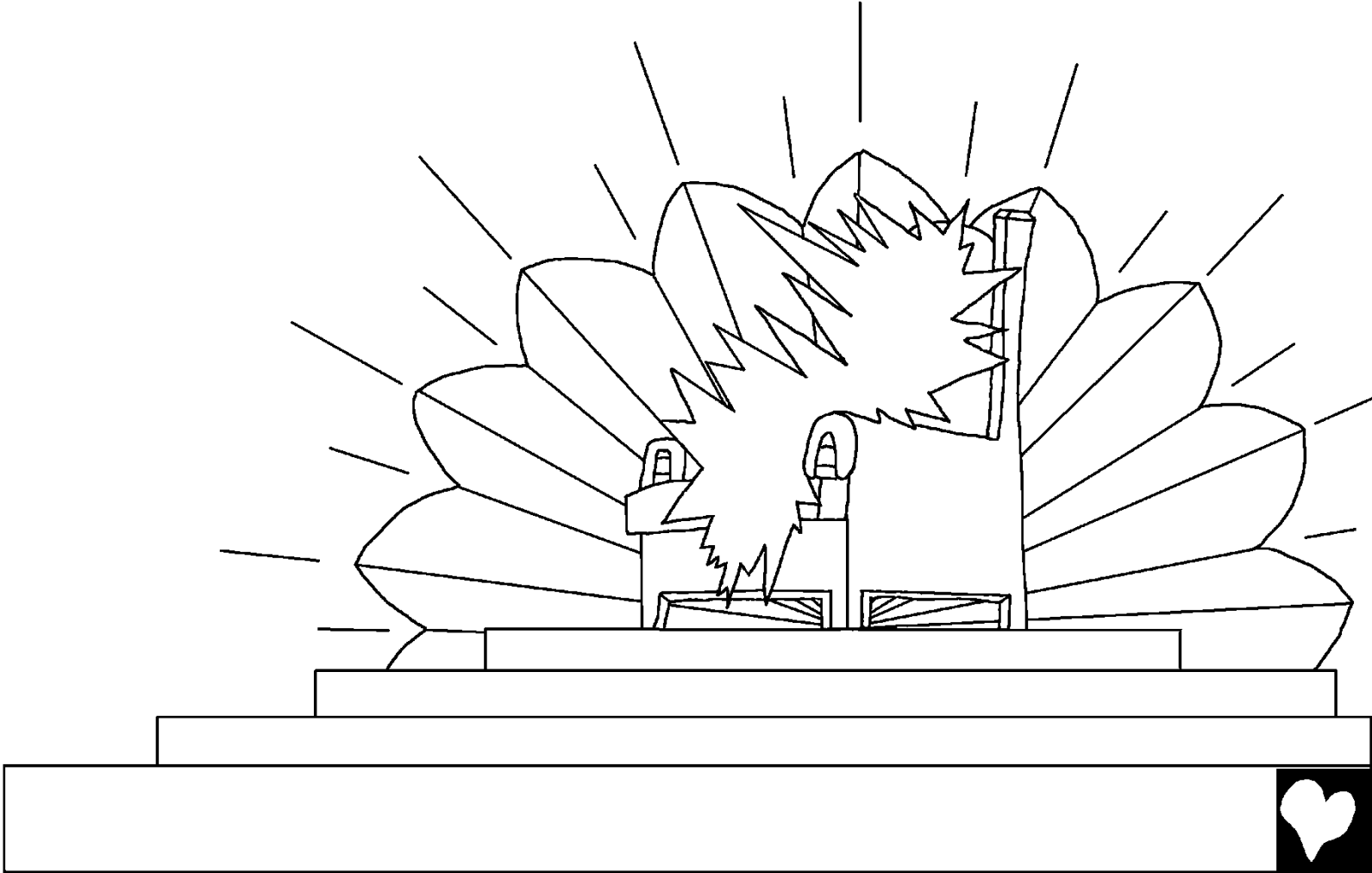

Se Ni kwa zi guru mbode Mirikisi yi a bisi, a kisi, a siki  
durinya a kisi kisi, nja a siki totolo riki nja guru mbo  
nsu leyi sua yi wonka nkye:

<<Yobo, nja girima, nja sori, ni  
yiko, te nja nsude zunwa a  
kingbolo solota yi, nja Yaa  
Timshiya Mirikisi ni gbogbo!>>

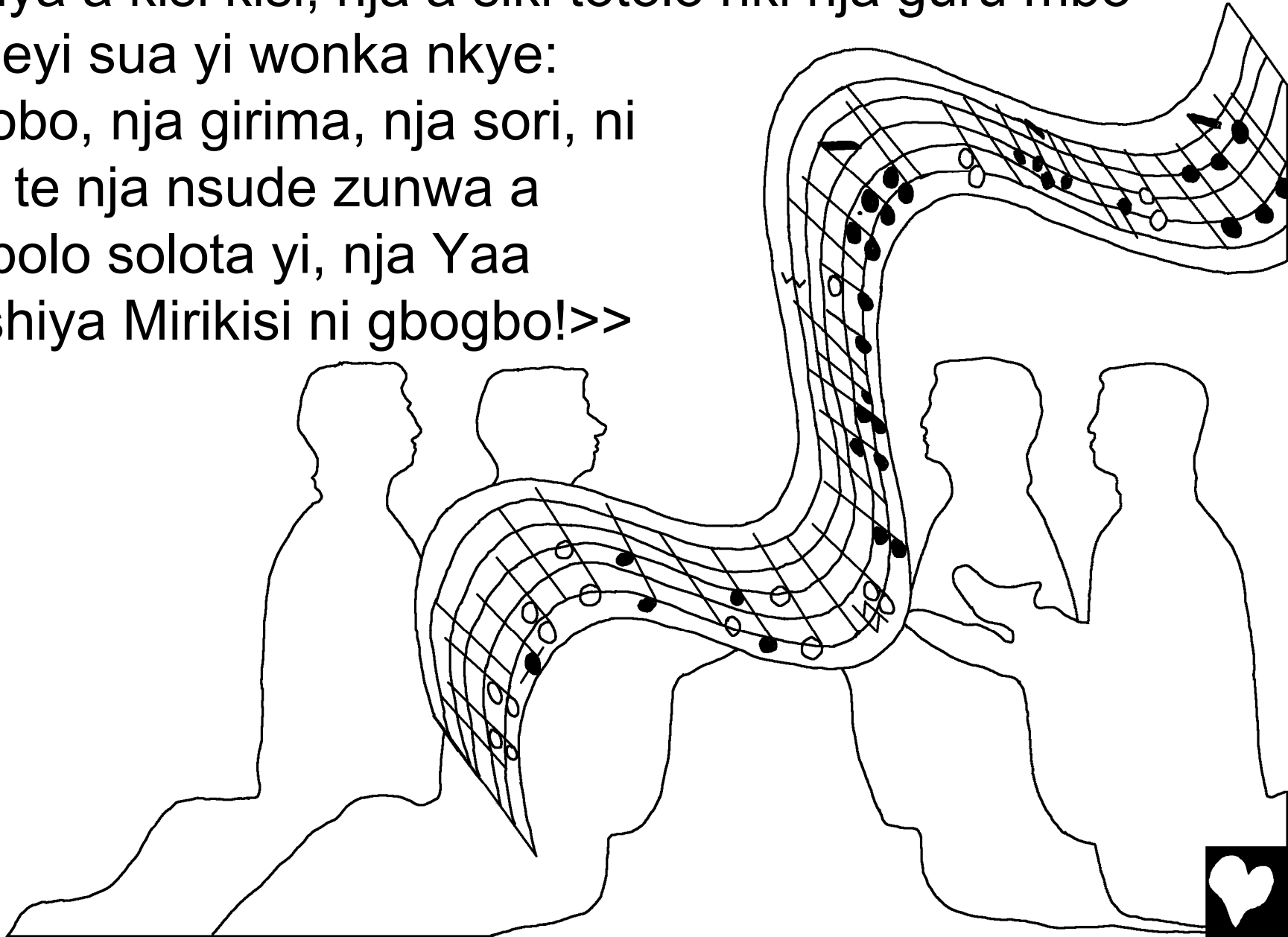

Ni geni totolo geri Nsuseki, sabuwa Wurishelima, ma sonka dege bisi anya Mirikisi, Mirikisi shiriya yi kankye okeshe de su yi gyaga kyakyawu ma pekye de e gom nja minji yi. Se Ni zi murinya daa yi beta nsori dege kingbolo solota: nkye, <<Kuzukam anya zunwa Mirikisi

ma nja ntani yi! yaa zunwa nja su, sua ma ntani yi. Mirikisi nkiya yi yaama nja su, yaa kwa ma Mirikisi asu, Mirikisi yaa shire su anwe a ndani asu.>>

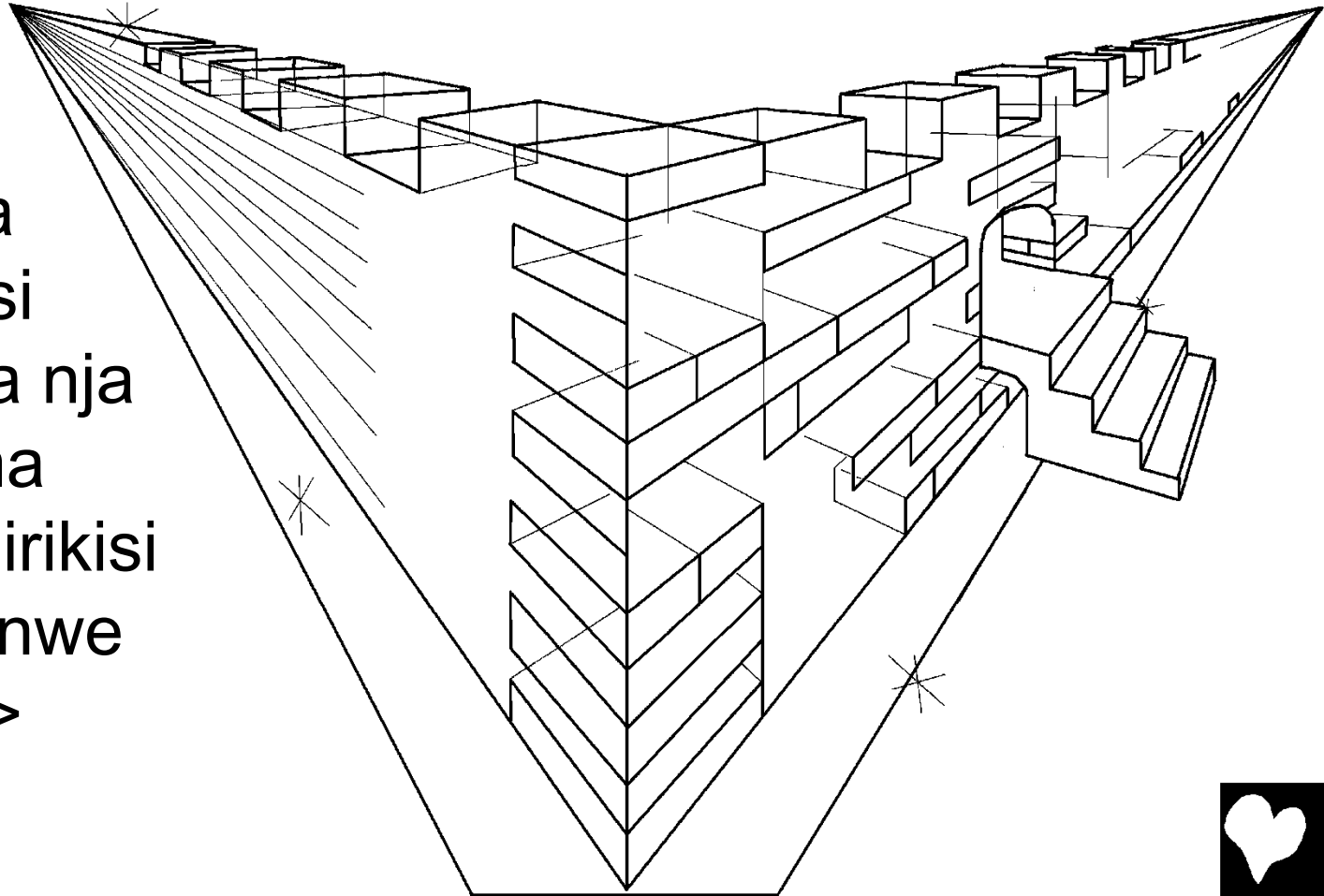

Se meleku Mirikisi nana ni totolo riki ni leyi, de ma yi asikye kankye gilasi, de ma sonka dege kingbolo solota ni Mirikisi nja ni Yaa Timshiya ni ma yi gudu a sisika turiki totolo geri.

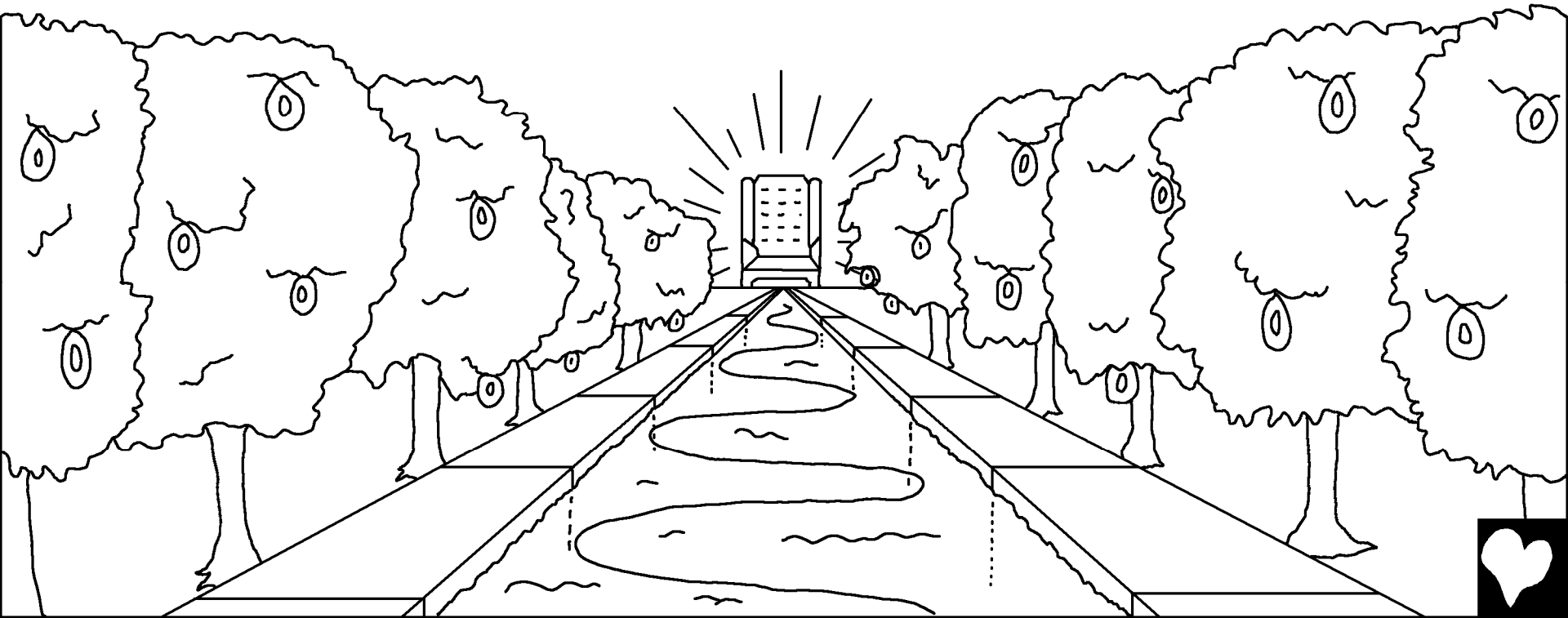

Totolo geri mu yaa bila asikye nana ko ni wonta ba,  
sobon dereja ni Mirikisi e shiya yaa ba yi asikye, nja  
Timshiya na ema kankye pitila yi.

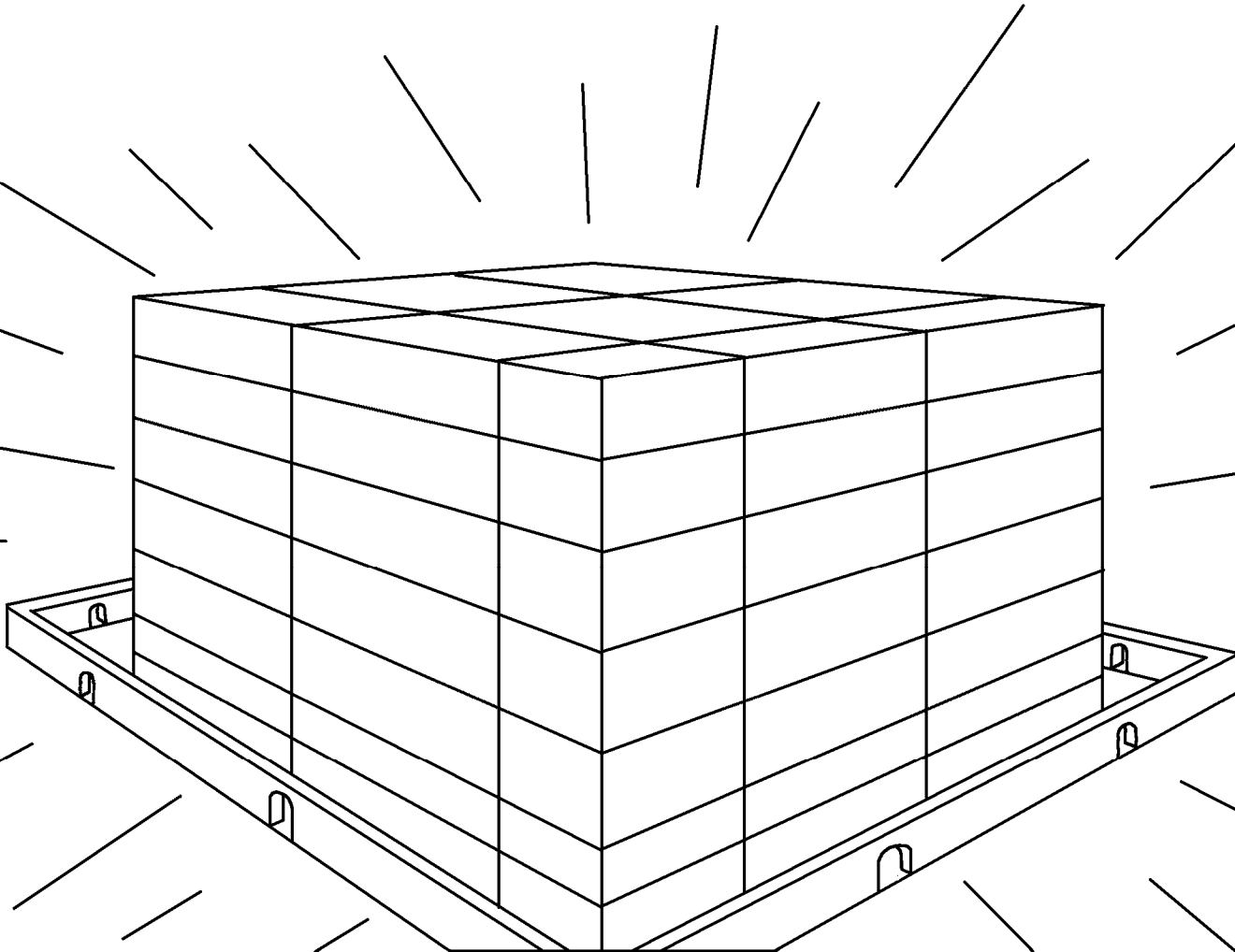

Sede ba mbode ma nsu dola de yaa yuru a siki yi ba,  
ko nsude yaa yi mbo ni kumnya ko nsu yaruwa, sede  
worede seni su ma a siki  
takada leyi ni Timshiya.



<<Mirikisi yaa shire su anwe a  
ndani asu. muntu yaa ma kuma  
gagaba ko beki siki ko kuka ko  
Genbeki, sobon wuri mbo rigye  
bise wo.>>



Ba mbodaa de ma ni arigbotu a totolo geri ni ba. Sede kingbolo solota ni Mirikisi nja ni Timshiya na yaa ma totolo geri ni, se nsu bunwa yi sua bowuta yi. Sua geni pisika yi nja sua rubuta seni yi a baki gan su.



Se Ni geni worede su muntu, toree nja yaya dende,  
sakisi a geba kingbolo solota. Su bure worosu takada,  
se su kwa bure takada daa de ma takada leyi. Se  
worede muntu su yi su shiriya kyakya ni mbode su yi,  
yiride ema a rubutu a siki takada woromu.  
Guru nsude su rubuta seni yi a siki  
takada ni leyi mu ba, su la yi kutiri  
te a siki totolo romu wuta mu.

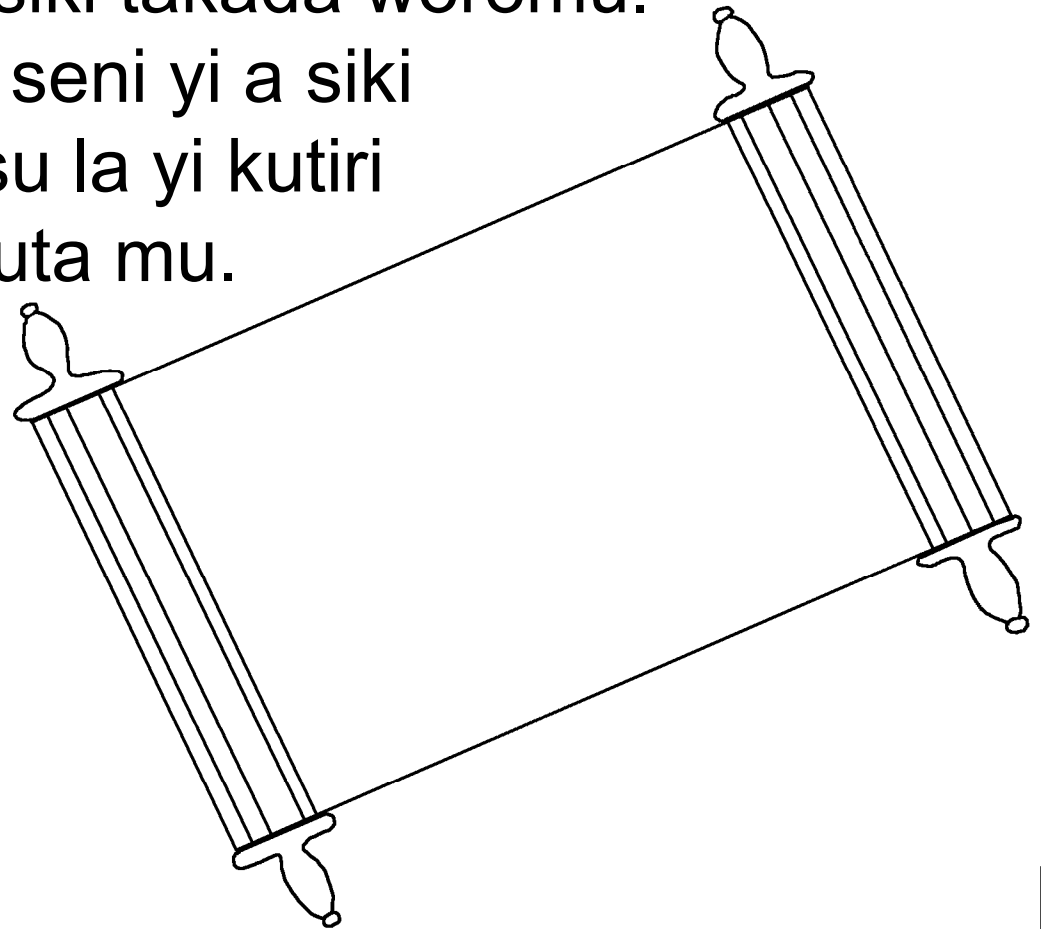

Aworo Mirikisi nja ntani Mirikisi nkye Yesu, <<Zo!>>  
Guru nsude zi nsum e shi ma e pala nkye, <<zo!>> du  
nsude yaa bila de sha riki, e zo; du nsude yaa bila riki  
nsu beyi leyi kyawuta.



Sobon so de Mirikisi yi ntani durinya  
mu ari e beyi Yaa yi ndandaa, sobon  
guru nsude yeda nja shi yaa muntu  
ba sede yaa mani leyi ni gbogbo.



Roman 3:23

Konwawa yi lepi nja mu yi nisa dereja Mirikisi,

Roman 6:23

Sobon nani wuta ni lepi e shiya ma muntu; sede  
kyawuta ni Mirikisi e shiya ma leyi ni gbogbo  
a siki Kiristi Yesu Obagizi mu.

Abi 9:27

Konse e ma dole na e muntu sen daa, a beyi  
nsum Mirikisi yaa yi shiriya,



Apisawa 2:8,9

Sobon ta anya aniyeri la mu samu sila, te anya beigaskye, da mu ma yi aku naba, sede kyawuta ni Mirikisi, ba sobon ni ANKI kyakyawu de mu yi naba, de kede nseda dege dolo.

Roman 10:9,10

Nde ki pala mbaki ke nkye, Yesu e ma Obagizi la, ki kwa beigaskye a siki dishiya ke nkye Mirikisi dege yi a kumsha, Mirikisi yaa sila nke. Sobon dege siki dishiya nsebeki yaa beigaskye de yi zunwa mere lepi a geba Mirikisi, ni baki la nsebeki yaa beyi sheeda de e samu sila.



## Joni 3:16,17

Sobon so de Mirikisi yi ntani durinya mu ari e beyi Yaa yi ndandaa, sobon guru nsude yeda nja shi yaa muntu ba sede yaa mani leyi ni gbogbo. Mirikisi saka Yaa yi a durinya ba de e yi ntani durinya shiriya naba, sede e sila ntani durinya.

## 1 Joni 5:11-13

Osu na e ma sheeda nkye: Mirikisi ba mu leyi ni gbogbo, leyi mu e ma a siki Yaa e yi na. Du nsude man Yaa e man leyi; du nsu de man Yaa ni Mirikisi ba e man leyi ba. Ni rubuta ku mbo worosu mu oku de ku yeda ni seni Yaa ni Mirikisi de ku shina nkye ku ma ni leyi ni dindindin.



Joni 14; 2 Korentiyawa 5; Revelation 4, 21, 22

Storyline by: Edward D. Hughes

Illustrated by: Lazarus  
and Alastair Paterson

Adapted by: Sarah S.

Gwandara NT (gwn) The Word for the World International  
and The Word for the World Nigeria

<https://www.bible.com/bible/4458/MAT.1.GAA>

©2026 Bible for Children, Inc.

[www.M1914.org](http://www.M1914.org)

[www.bibleforchildren.org](http://www.bibleforchildren.org)

