

**Littafi mai Tsarki na yara**

**Ke gabatar da**

**Sama'ila,  
Dan Hidimar  
Allah**



**Wanda ya Rubuta: Edward Hughes**

**Mai Zane: Janie Forest  
Alastair Paterson**

**Mai niyyan daukan nauyi: Lyn Doerksen**

**Fassarawa: Bible Society Nigeria**

**Wanda ya Wallafa: Bible for Children  
[www.M1914.org](http://www.M1914.org)**

**©2024 Bible for Children, Inc.**

**Zaku iya kofan wanna labarin ku wallafa idan  
har ba zaku sayar da shi.**



**Hannatu mace ce mai kirki, ta auri Elkana, mutumin kirki. Dukansu sun yi wa Allah sujada suna aikata nagarta ga mutane. Amma akwai abin da Hannatu ba**

**ta da shi a rayuwarta. Tana so ta sami yaro. Oh, ina misalin hanzarin ta sami jariri! Ta yi ta jira, tana addu'a tana sa rai tana jira na lokaci. Babu yaron da ya zo.**

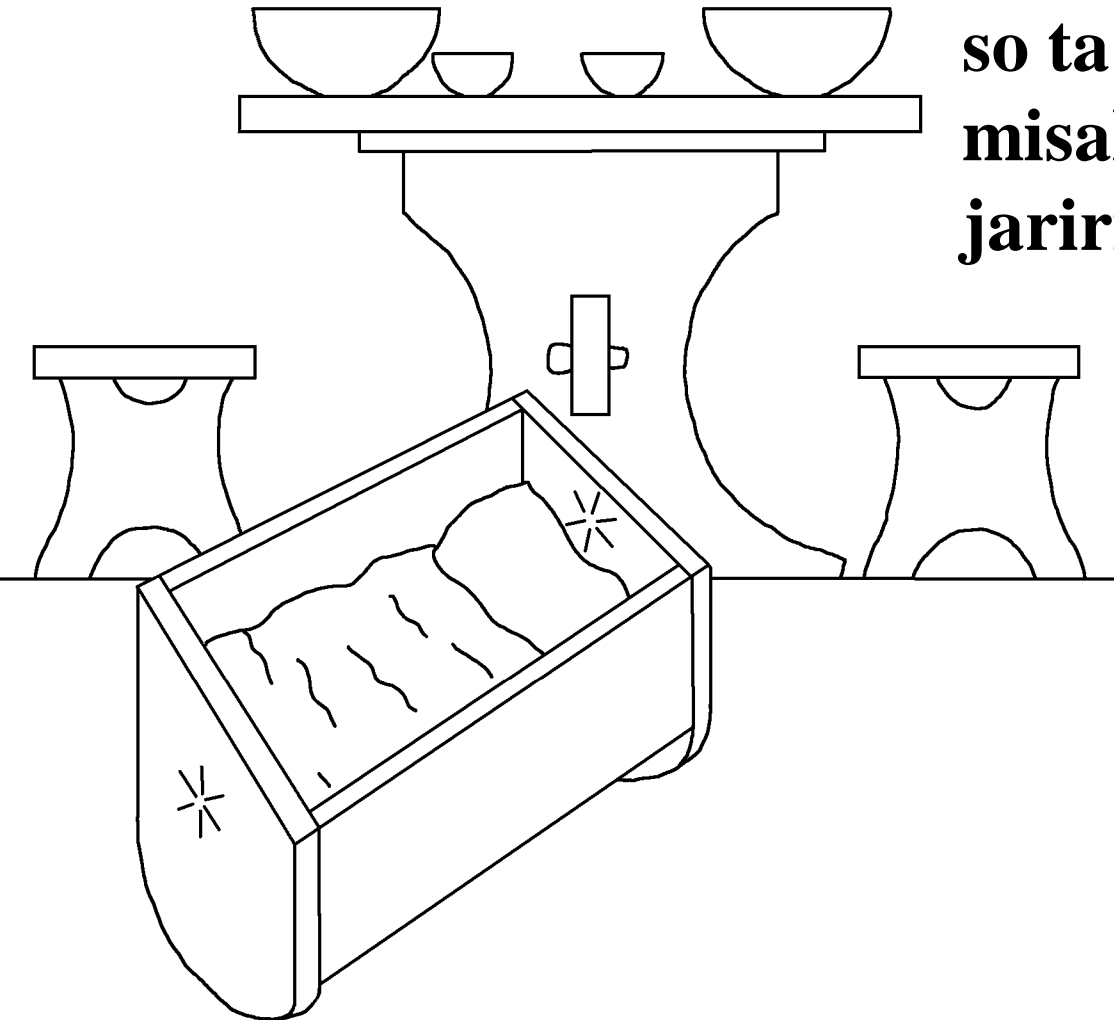



**Kowane shekara, Hannatu  
takan tafi ta yi sujada a  
haikalin Allah. Wani  
shekara sai ta yi wa Allah  
alkawari cewa in ya ba ta  
da namiji, za ta ba wa  
Allah yaron ya yi masa  
hidima har abada.**



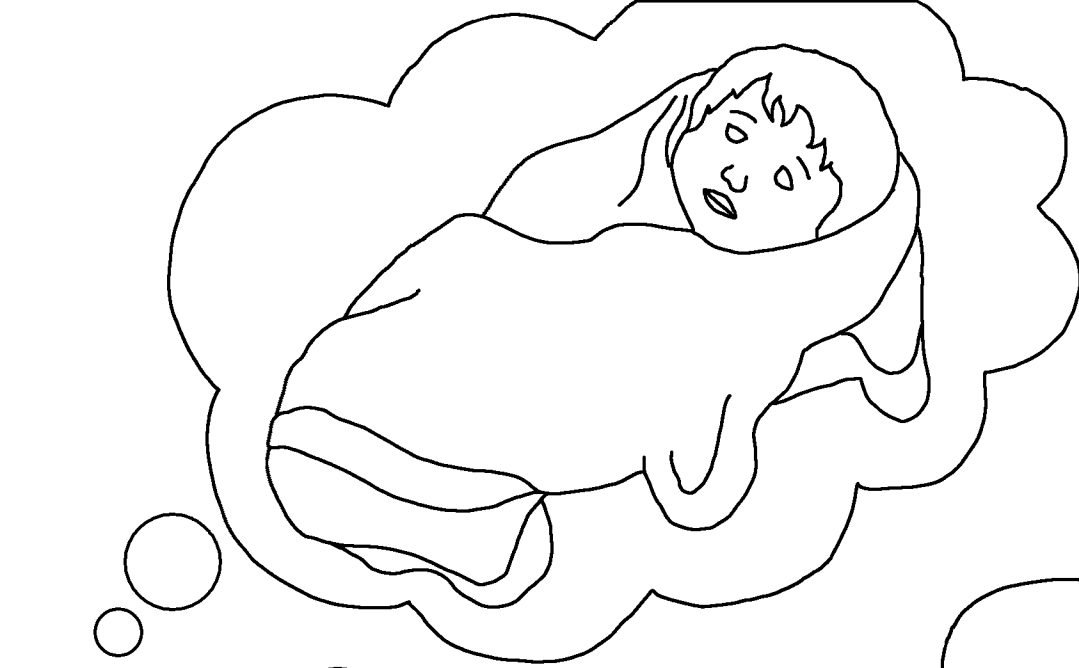

**Eli tsohon Firist ya hange Hannatu tana addu'a. Yana tuna nin watakila Hannatu ta bugu ne da ruwan inabi saboda ya gan leben bakinta yana motsi amma bai ji kalmomi suna fita ba. Eli ya yi mata fada.**



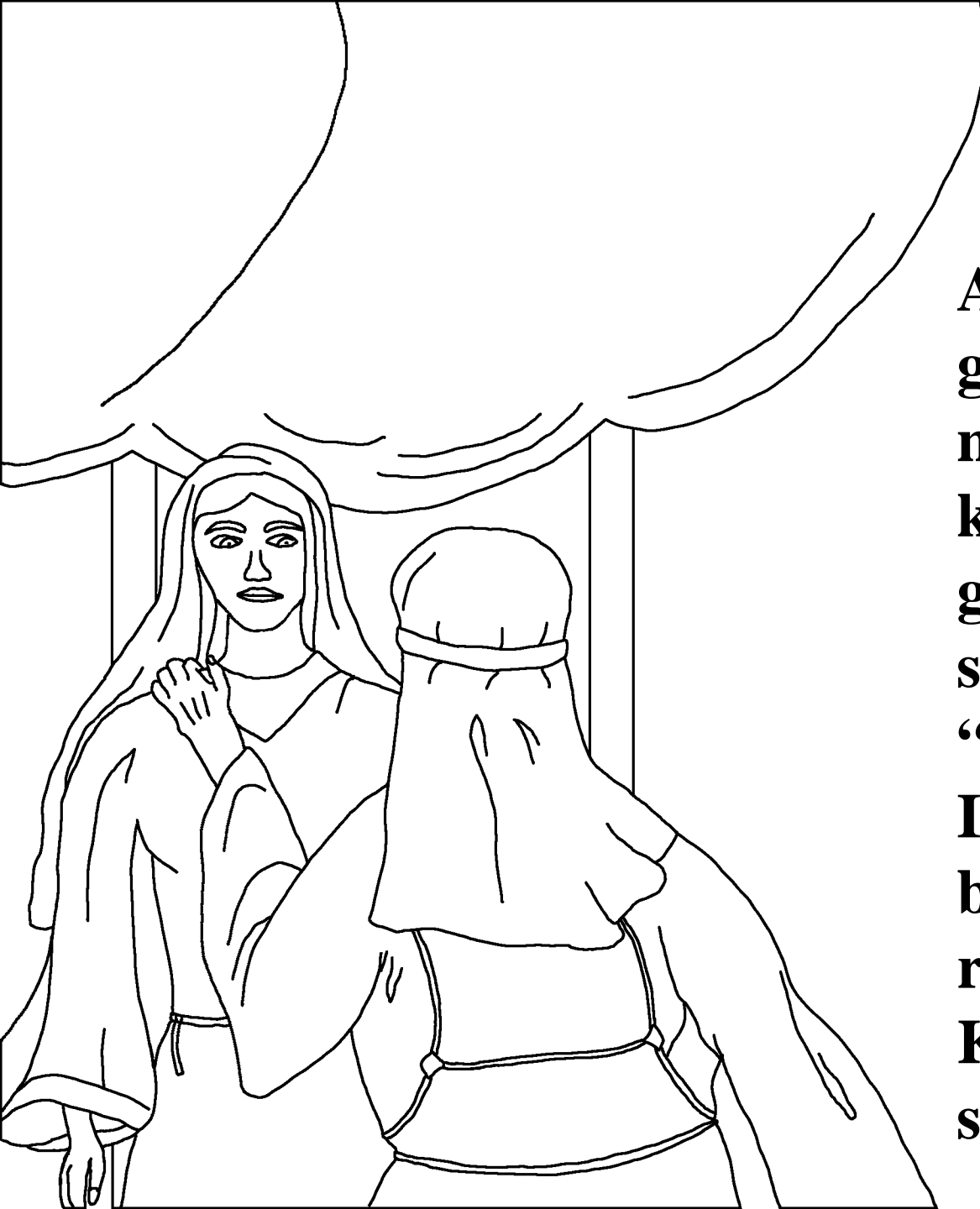

**Amma Hannatu ta  
gaya wa Eli addu'arta  
na neman yaro da  
kuma alkawarinta  
ga Allah. “Tafi cikin  
salama.” Eli ya amsa.  
“Kuma Allah na  
Isra'ila ya biya miki  
bukatanki wanda kika  
roka daga gareshi.”  
Kalmomin Eli  
suka ba ta bege.**



**Ba dadde ba sai farin ciki ya cika zuciyar Hannatu.  
“UBANGIJI ya tuna da ita” ya kuma amsa addu’arta.  
Da ita da Elkana suka sami yaro wanda suka ba shi  
suna Sama’ila. (mai ma’ana “Allah ya ji”). Amma ko  
Hanantu za ta tuna da UBANGIJI da alkawarinta  
gareshi?**

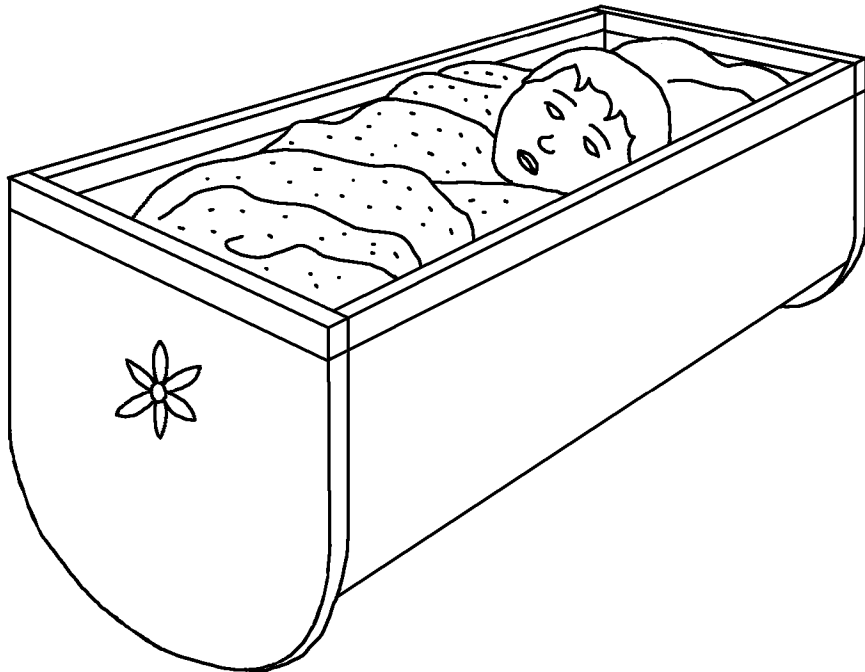



**Hannatu ta bar zuwa haikalin kowace shekara. Oh, aminiyata! Ta karya alkawainta ga Allah kenan? A'a, Hannatu tana jira ne sai Sama'ila ya yi girma ya kai yadda zai zauna da Elai yana taimake shi a tentin da hidimar Allah. Sa'an nan ta kawo shi a tentin.**





**Allah ya daukaka  
amincin Hannatu  
mai girma. Bayan  
Sama'ila, Allah ya  
ba ta 'ya'ya maza  
uku da 'yan mata  
biyu. Kowane  
shekara Hannatu  
takan tafi tentin  
domin ta yi wa  
Allah sujada – ta  
kuma kai sabon  
rigar ta yi wa  
Sama'ila.**



**Ba Sama'ila ne kadai mataimakin Eli ba.  
'Ya'yan Eli Hofni da Finehas, su ma sun  
yi aiki a wurin. Amma ba su daukaka  
sunan Allah ba ta wurin mugayen  
ayyukan da suka aikata, kuma sun ki su**

**canja duk da rokon  
da babansu Eli ya  
yi. Yakamata da  
Eli ya kore su daga  
yin aiki a tentin.  
Amma bai yi ba**

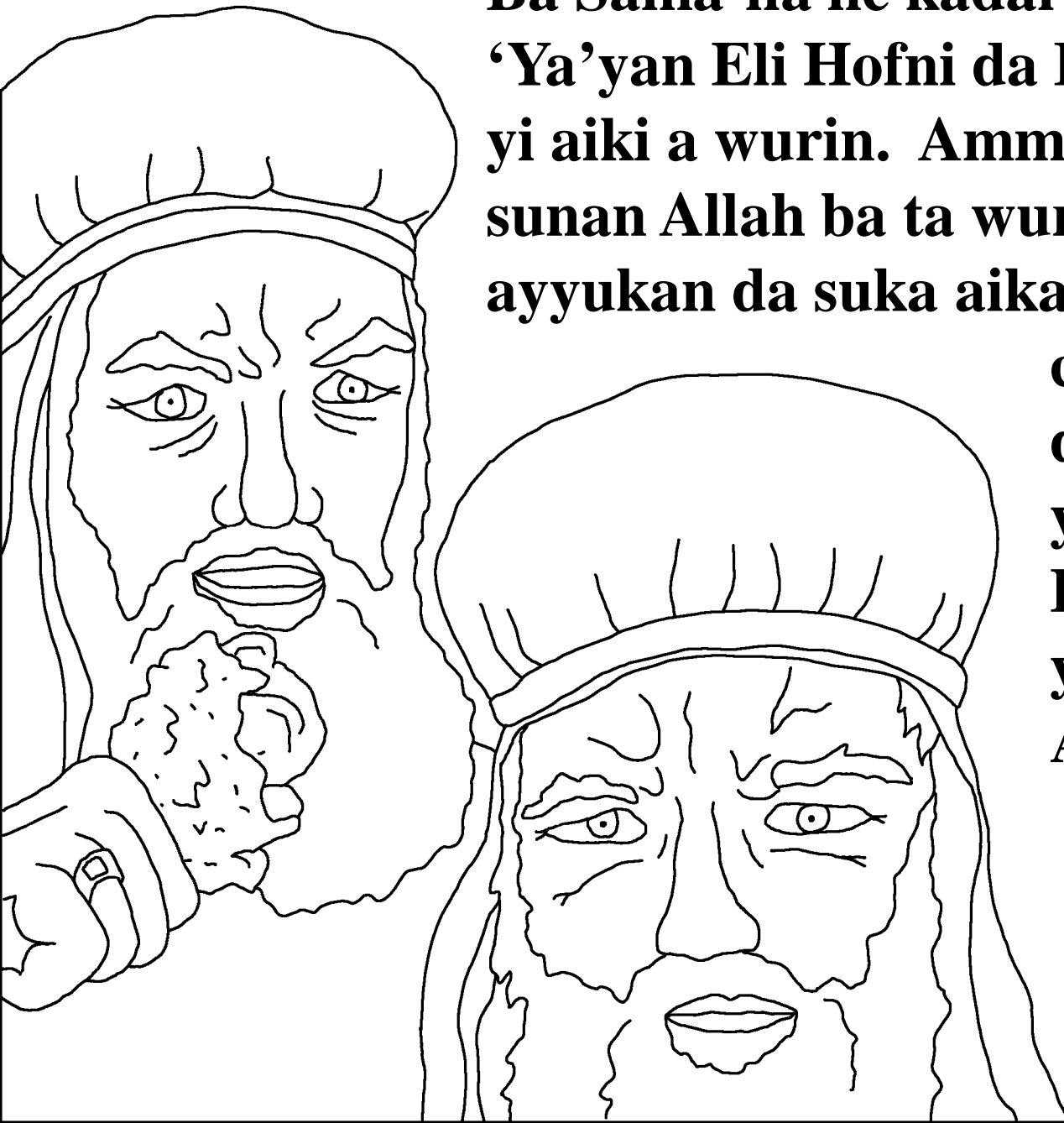

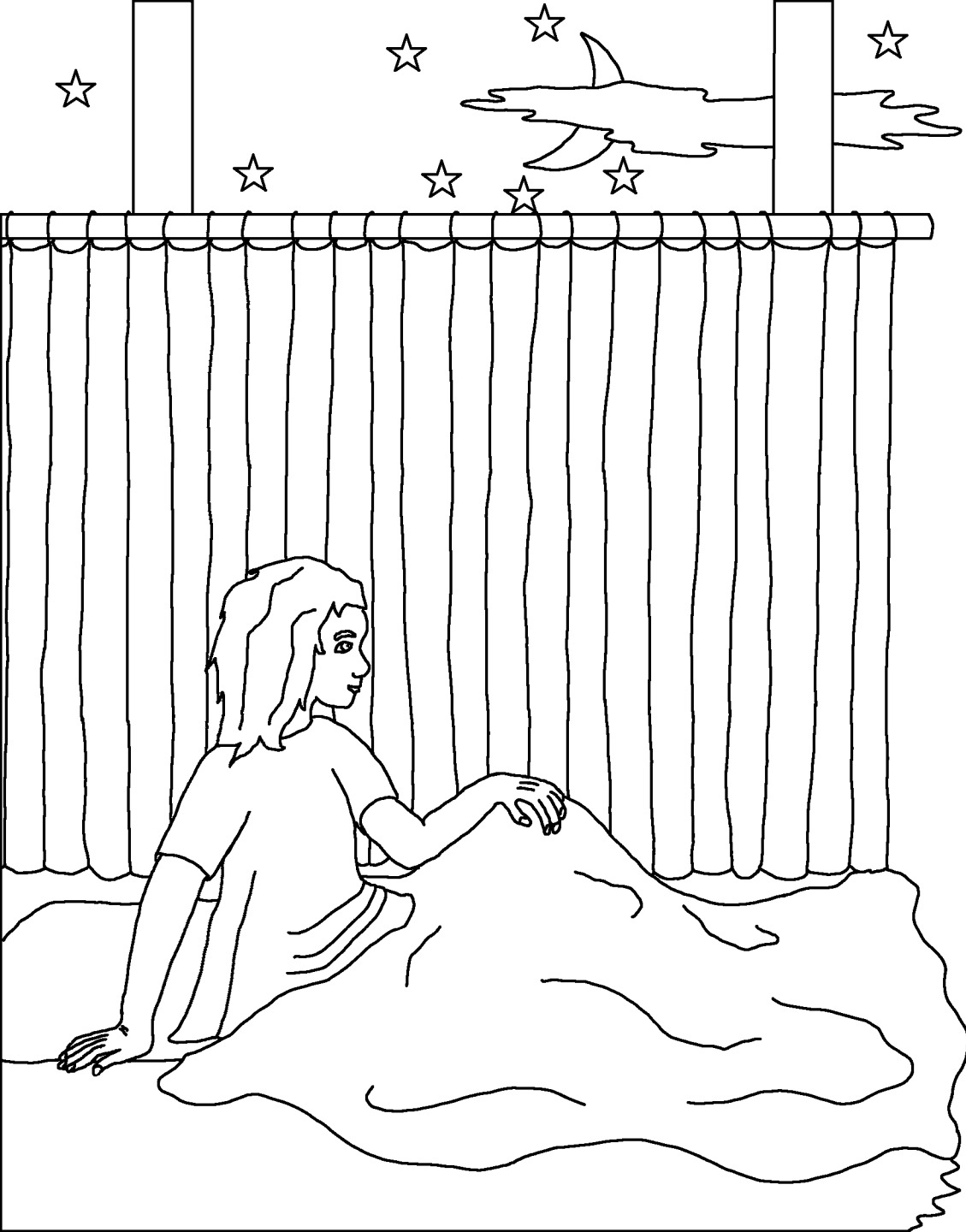

**Wani dare, Sama'ila ya ji murya na kiransa. Saurayin yana gani kamar Eli ne yana kira. "Ga ni nan," ya ce. "Ban kira ka ba," Eli ya amsa. Wannan ya faru sau uku. Sai Eli ya sani cewa Allah yana so ya yi magana da Sama'ila ne.**



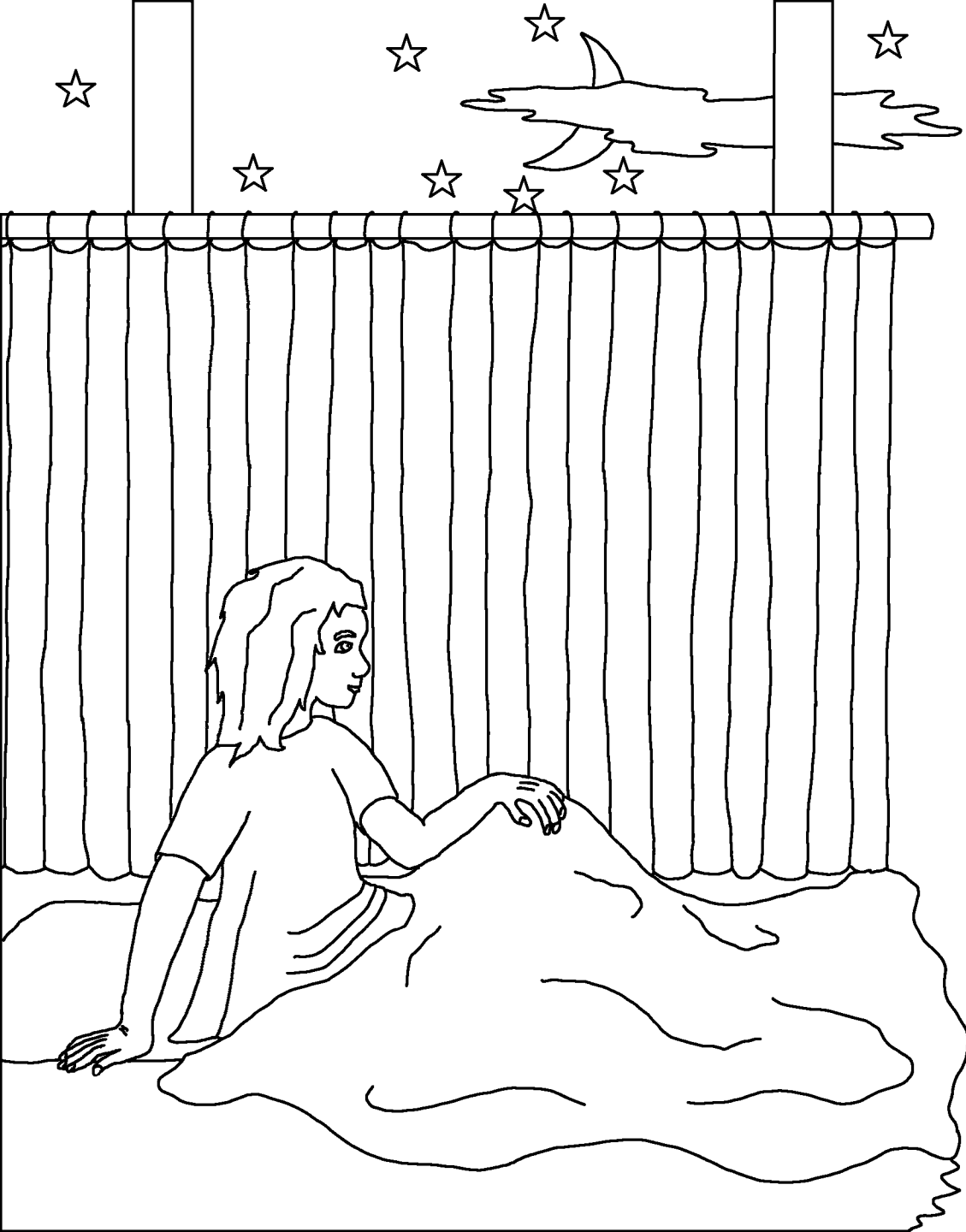

**Eli ya gaya wa Sama'ila, "Idan ya kira ka, dole ka ce, 'Yi magana UBANGIJI, gama bawanka yana ji.'" Allah kuwa ya kira, sai ya ba wa Sama'ila sako mai muhimmanci.**



**Da safe Eli ya kira Sama'ila. "Mene ne abin da UBANGIJI ya fada maka?" ya tambaya. Saurayi Sama'ila ya gaya masa kome da kome. Mugun sako ne – Allah zai hallakar da duka iyalin Eli saboda Hofni da Finehas sun yi mugunta sosai.**



**Gargadin Allah ya zama gaskiya. Lokacin yaki tsakanin Isra'ila da Filistiyawa, mugayen 'ya'yan Eli guda biyun nan suka jagorance yakin rike da Akwatin Allah a gaban sojojin Isra'ila. Abokan gaban suka kwace Akwatin sai suka kashe Hofni da Finehas tare da Isra'ilawa masu yawa.**

**Sa'ad da Eli ya ji labarin, sai ya fadi daga kujerarsa, ya karya wuyansa, ya mutu rana daya da su.**



**Akwatin ya jawo wa Filistiyawa matsifa. Suka sa shi a haikalin Dagon, allahnsu na karya. Da safe, gunkin Dagon ya fadi da fuska a kasa. Filistiyawa suka ta da shi daga kasa – amma washegari kuma sai ga shi a kasa. A wannan karon Dagon ya faffashe.**

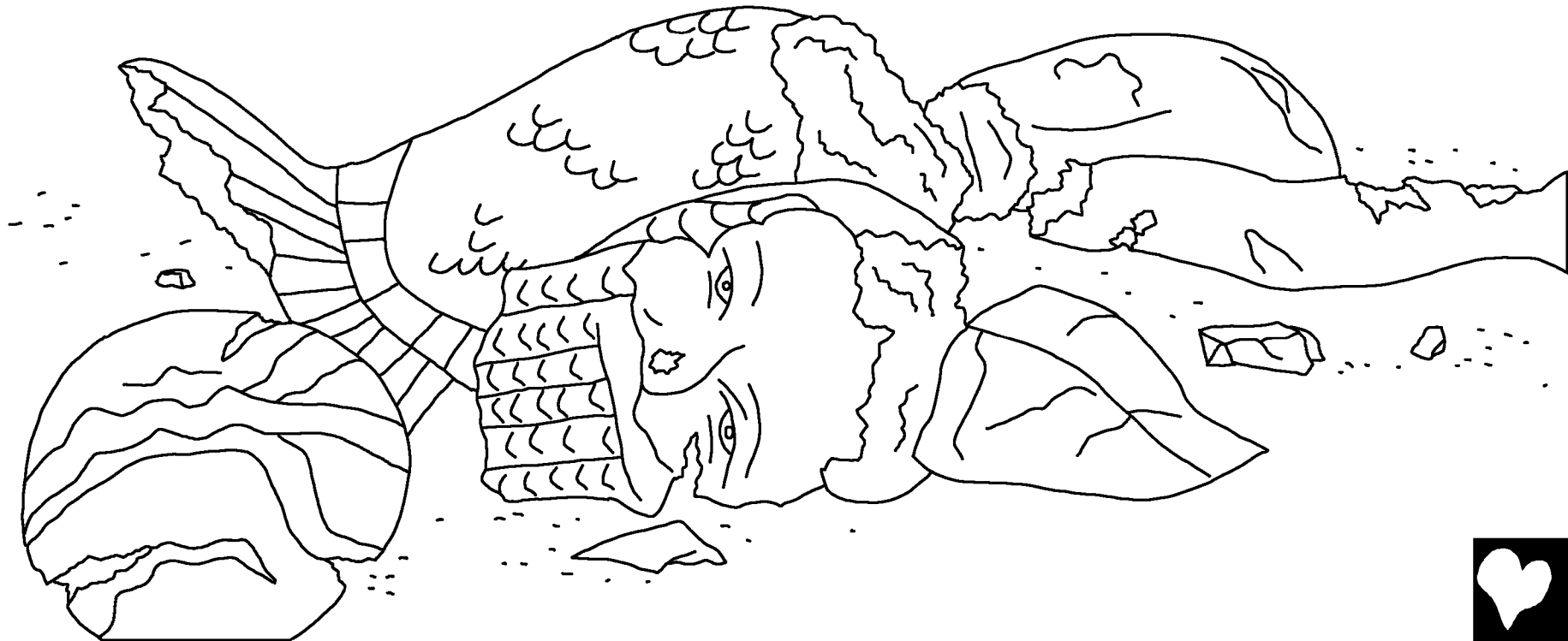

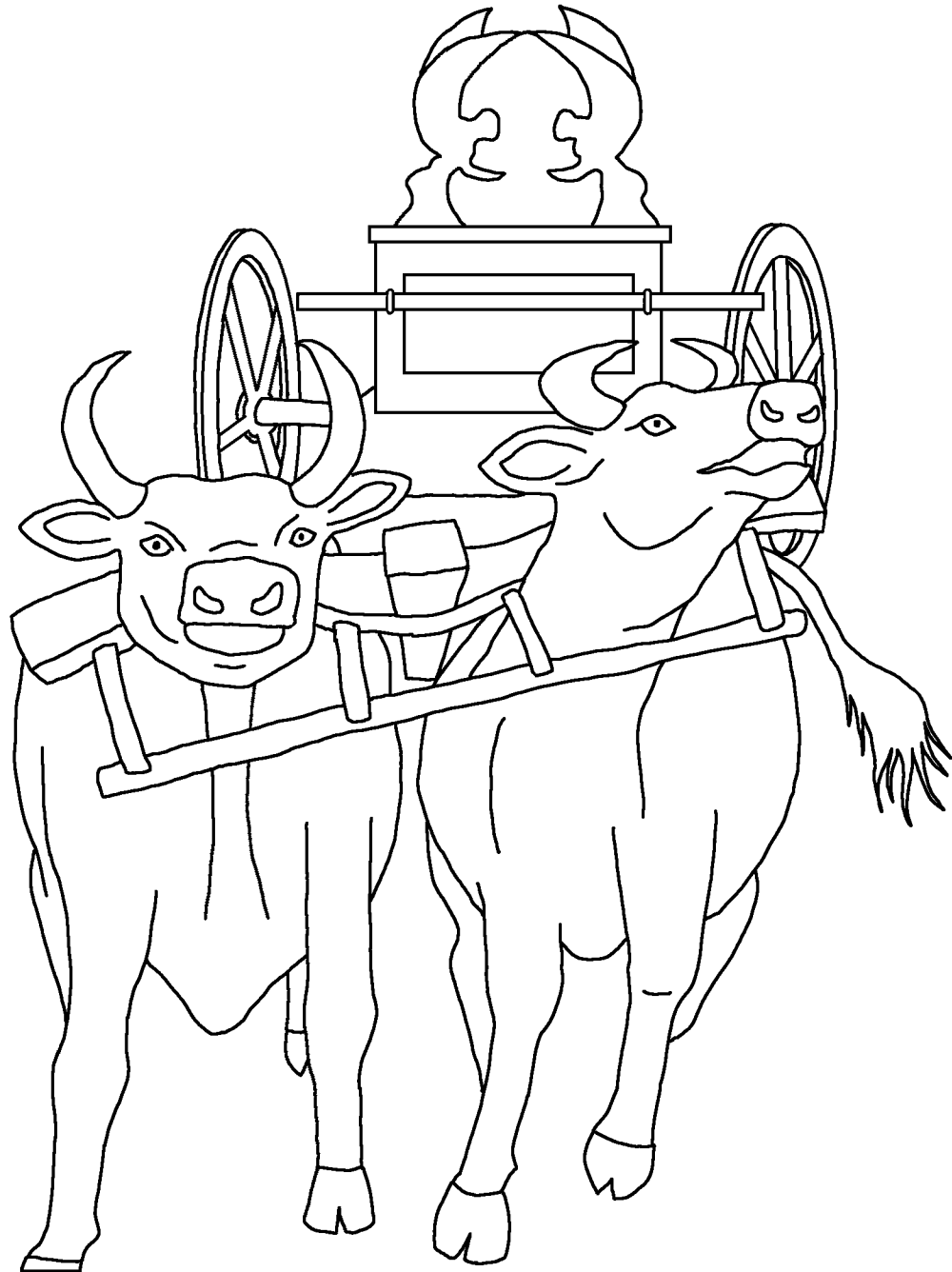

**Ciwo da mutuwa ya bazzu ko'ina a tsakanin Filistiyawa. Domin su sani ko Allah yana hukunta su ne, sai Filistiyawa suka sa shanu biyu su ja Akwatin. Amma suka bar yaran shanun a wurinsu. “Idan shanun sun haura zuwa Isra'ila, sai suka bar ‘ya’yansu, za mu sani cewa Allah ne ya aikata wannan,” suka ce. Haka shanun suka haura!**



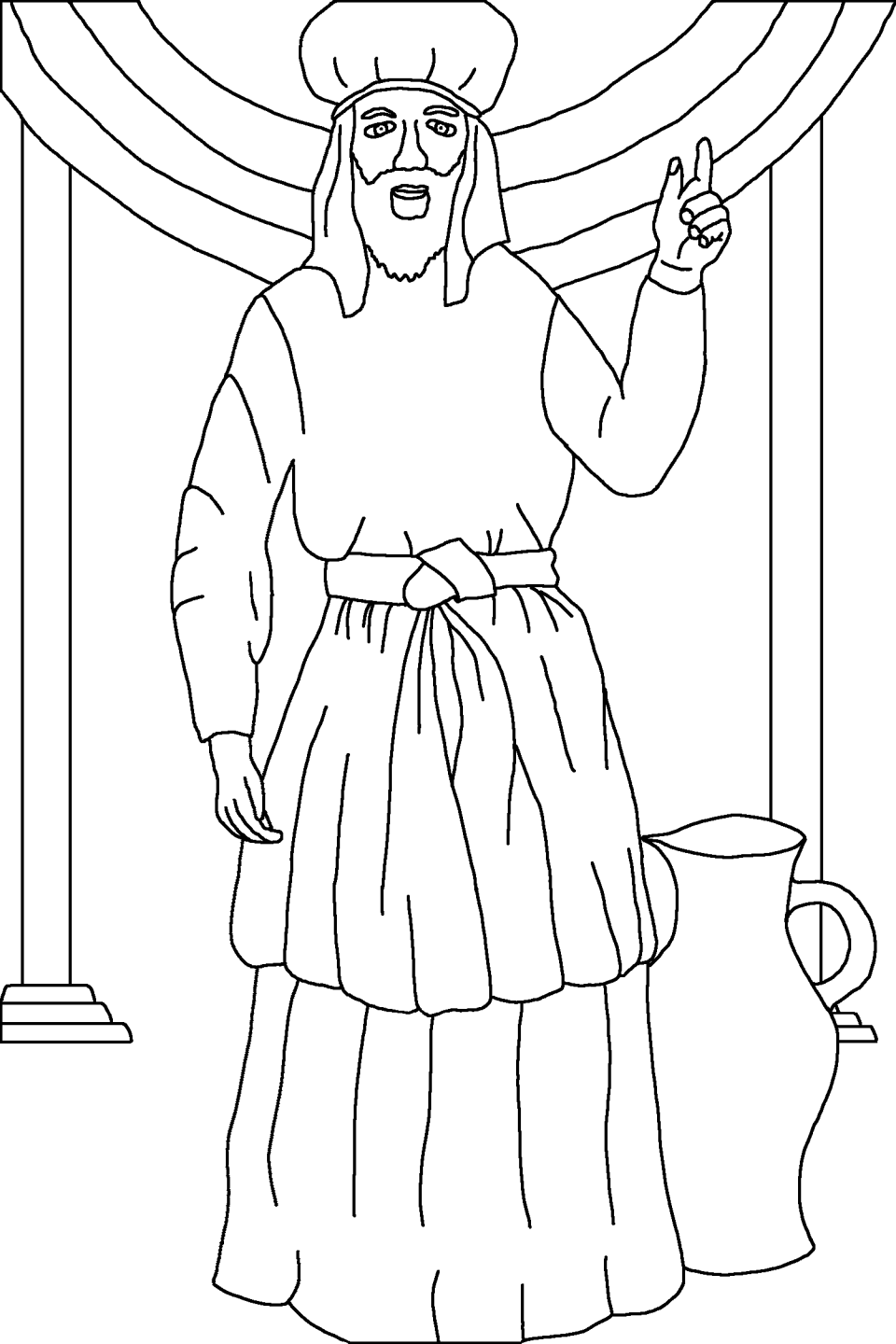

**Sai Sama'ila, wanda yanzu ya yi girma, ya yi magana da duka mutanen Isra'ila. "Idan kuka dawo wurin UBANGIJI da dukan zukatanku... Zai kubutar da ku daga hannun Filistiyawa." Mutanen suka yi biyayya ga annabi mai aminci na Allah. Hannun Ubangiji ya sauka a kan Filistiyawa duka kwanakin Sama'ila.**



**Sama'ila, Dan Hidimar Allah**

**Tahiri da ga maganar Allah, littafi mai Tsarki**

**a na samu a**

**1 Sama'ila 1-7**

**“Shigowar maganar ka yana baduar kawo  
haske.” Zabura 119:130**



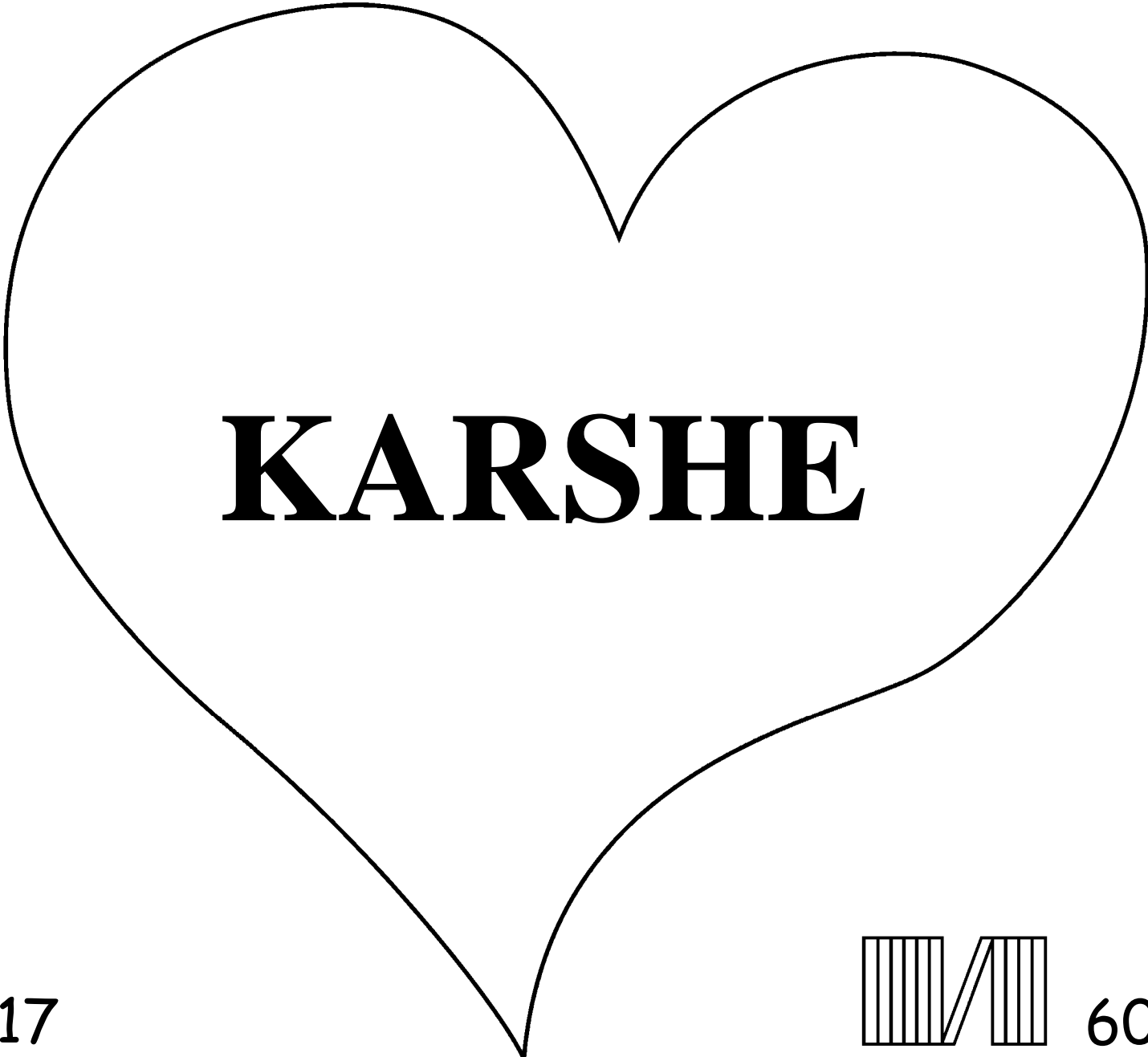

**KARSHE**

17

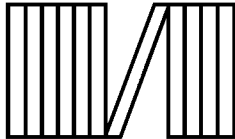

60



**Wanan tahiri daga littafi mai-tsarki na mana bayanin  
Allah mu wanda ya halicce mu wanda yake son mu san shi.**

**Allah ya san da cewa mun yi abubuwan da ba su da kyau, wanda yake  
kira zunubi. Sakamakon zunubi mutuwa ne, amma Allah ya na  
kaunan mu sosai. Ya aiko da Dansa Yesu, ya mutu a kan giciye ya sha  
wahala domin zunuban mu. Kuma sai Yesu ya tashi daga matattu ya  
koma gida a sama. Idan ka bada gaskiya ga Yesu. Ka rokeshi gafaran  
zunuban ka, zai yafe. Kuma zai zo ya zauna a cikin zuciyar  
ka kaima kuma zaka zauna a zuciyar shi har abada.**

**Idan ka yadda da wannan gaskiya ne, Ka cewa Allah:  
Ya Yesu, na bada gaskiya kai Allah ne, ka kuma zamu mutum don ka  
mutu domin zunubi na, kuma yanzu ka tashi. Ina rokon ka, ka shiga  
cikin zuciya na kuma ka yafe min zunubai na, Domin in samu sabon  
rai yanzu, kuma wata rana in zauna tare da kai har abada. Ka  
taimake ni in yi maka biyayya kuma in yi rayuwan da  
zai gamshe ka a matsayin dan ka. Amin.**

**Ka karanta littafi mai-tsarki kuma ka yi magana da  
Allah a kulla yaumin. Yahaya 3:16**

