

[www.BibleForChildren.org](http://www.BibleForChildren.org)

# Yahiya 14

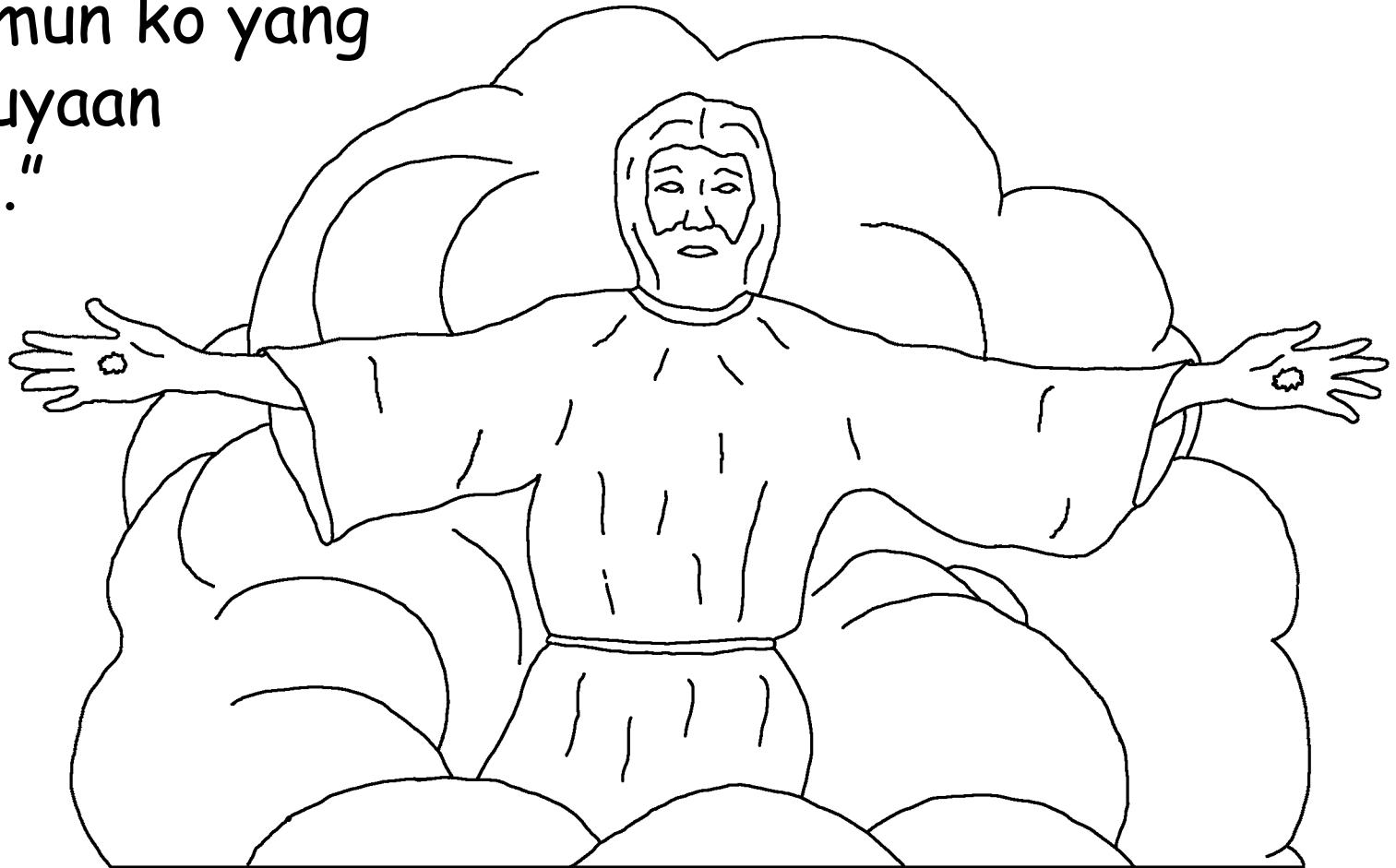

Ansinyan yagalaong si Isa sang mga inindowan nan,  
"Ayaw kamo magkarido. Pagsarig sang Tohan aw  
pagsarig oman kanak. Adto sang baay ng kanak Ama  
madaig yang mga kowarto. Kong di yan ng bunna, di  
ako magalaong kamayo na makadto da ako antak  
andamun ko yang  
pagauyaan  
mayo."



"ANa, pagkatapos aw maandam da ko, magabarik ako  
adi aw paagadun ta kamo kay antak daw wain ako,  
idto oman kamo."



Ako si Yahiya sambok na lomon mayo, aw sabap  
sang pagkasambok natun kang Isa kaupdanan  
oman mayo sang pagsabar ng mga

kasikotan na madatung  
sang mga otaw na



yamasakop sang  
pyagadatowan  
nan.



Sangaon dyadaa ako na magonawa ng piniriso adto  
sang poo ng Patmos sabap ng yagaosiyat ako ng  
pyaglaongan ng Tohan aw yang

kabunnaan na pyapakatigam  
kanak ni Isa.

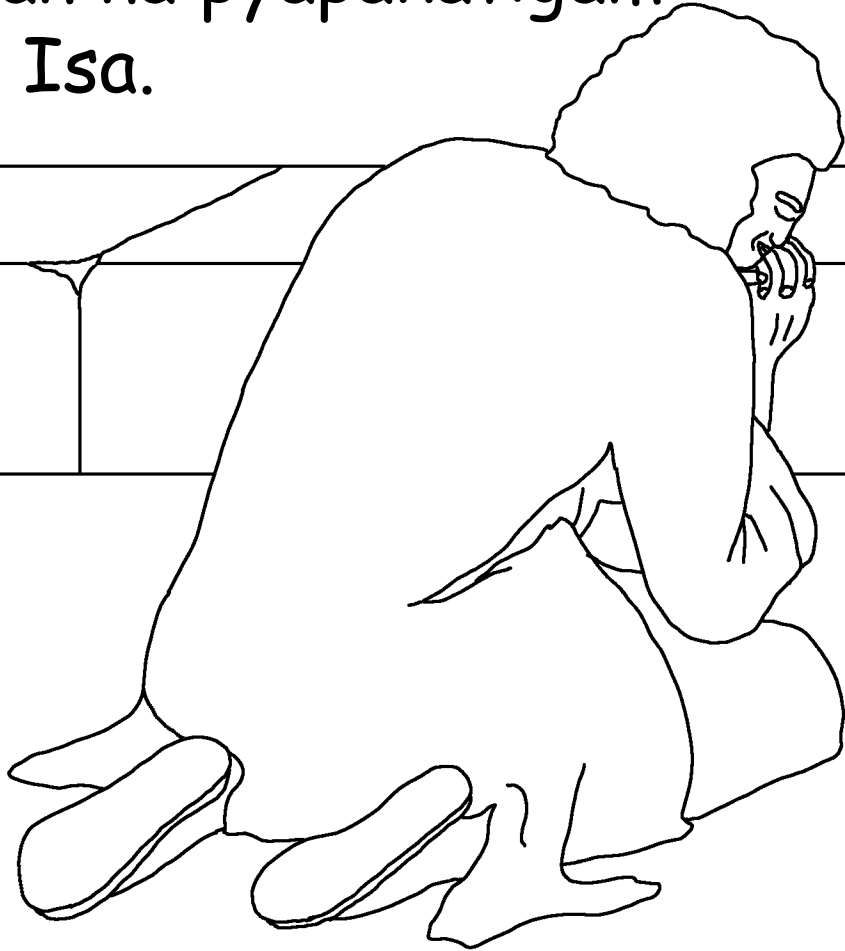

Sakadyap pyagabuutan ako ng Nyawa ng Tohan aw  
kikita ko adto sang sorga yang sambok na ingkodanan  
ng soltan aw aon yagaingkod ansan.



Ansinyan yamadungug ko na yanagkanta oman yang  
kariko ng mga byabaoy ng Tohan, yang kariko na adi  
sang sorga, adto sang donya aw  
adto sang saad ng lopa aw adto  
oman sa suud ng dagat.

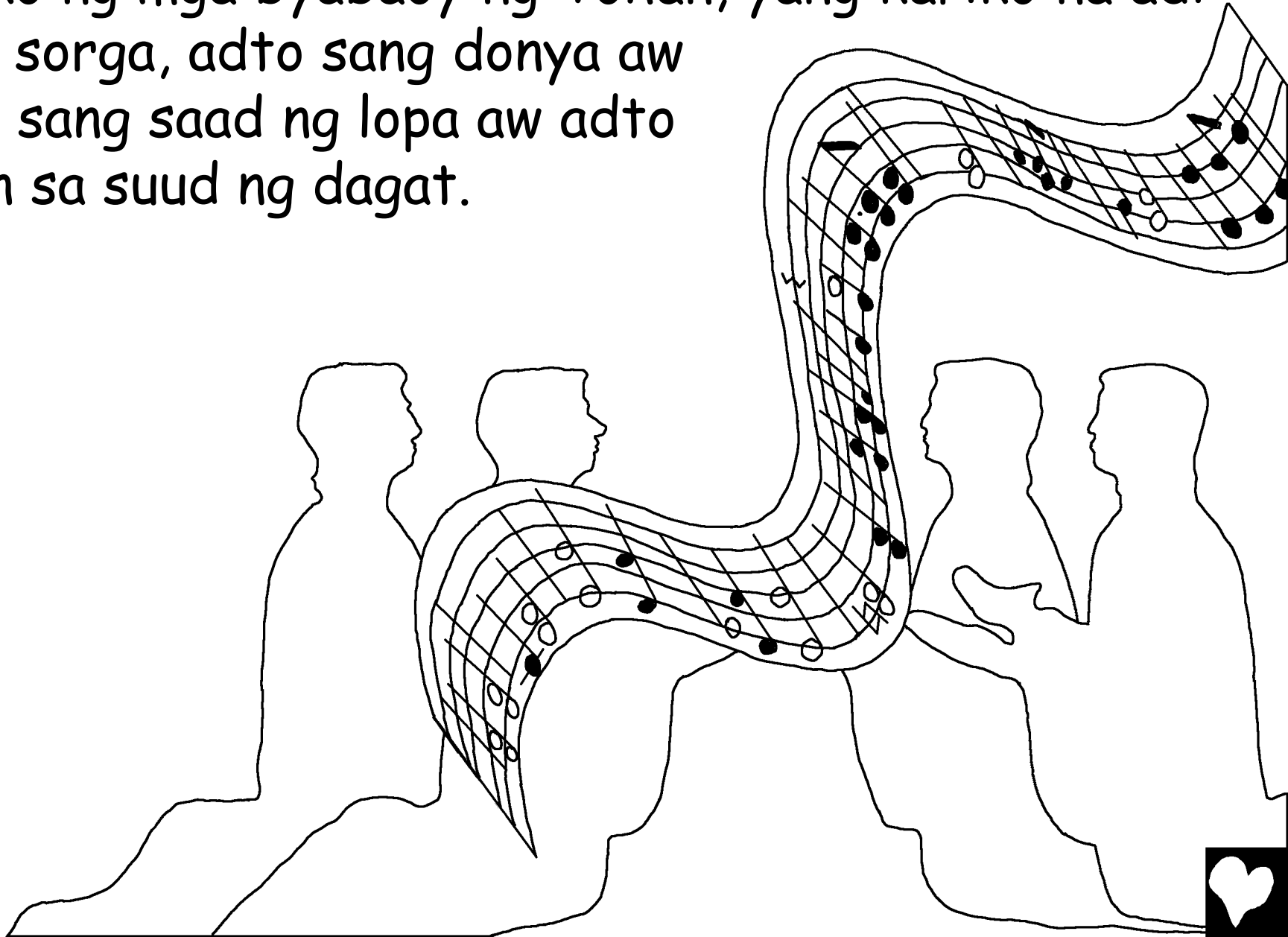

Laong nilan, "Pojiun ta yang yagaingkod sang  
ingkodanan aw yang Karniro. Dait silan bantogon aw  
pojiun taman sa taman kay kanilan  
yang kariko ng kabarakat!"

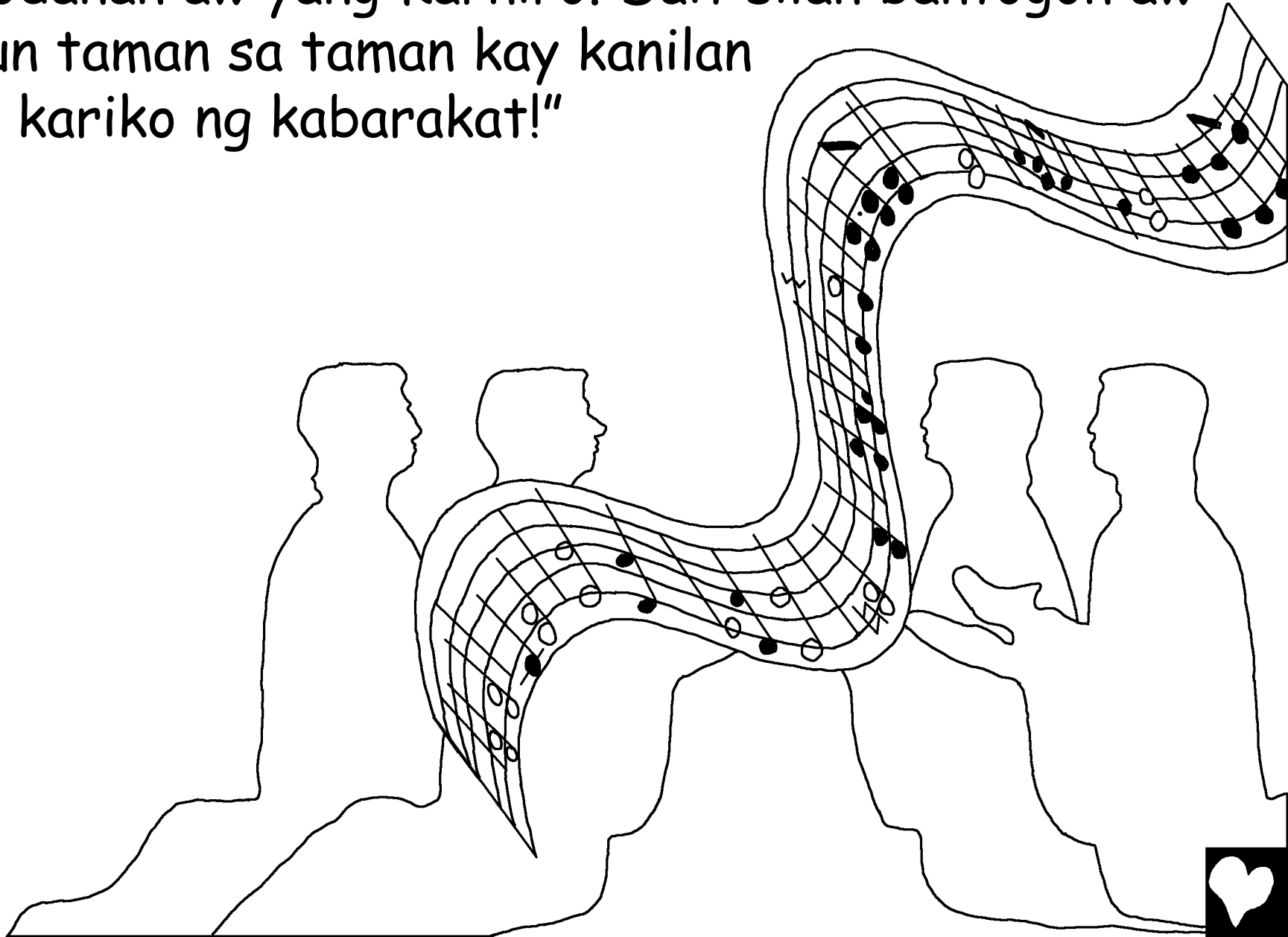

Aw kikitita ko yang sotti na syodad na yan yang bago na Awrosalam na pyapakunsad ng Tohan sikun sang sorga. Madyaw yan tanawon na maynang bobay na akawinun da sang kanan bana.

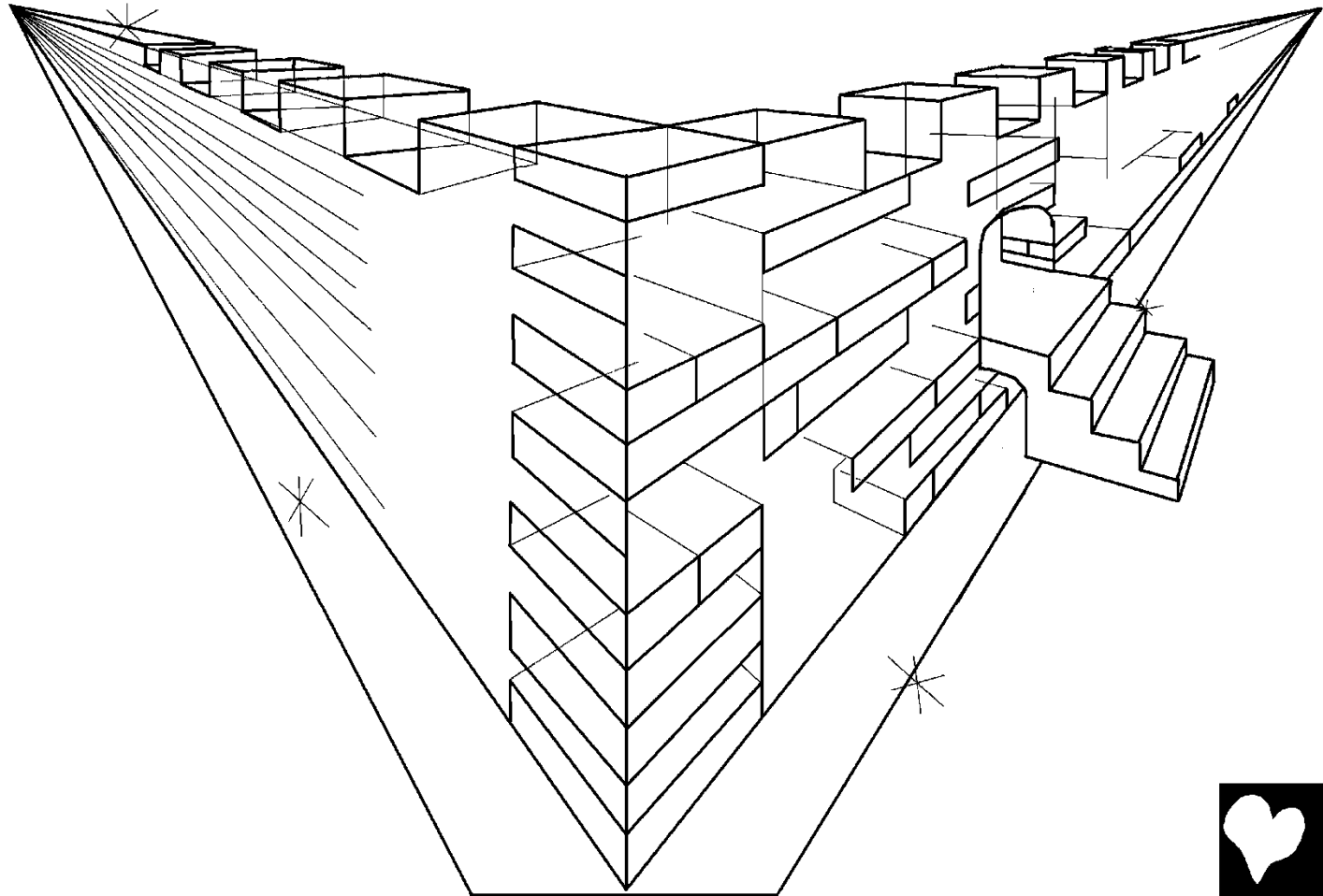

Ansinyan aon dyudungug ko na matanog na sowara sikun sang ingkodanan ng Tohan na yagalaong, "Adon, sambok da yang pyagauyaan ng Tohan aw yang mga otaw kay iyan da yan magauya upud kanilan. Yang Tohan magapabilin kanilan kay yan da yang Tohan nilan aw silan yang mga otaw na sakop nan."

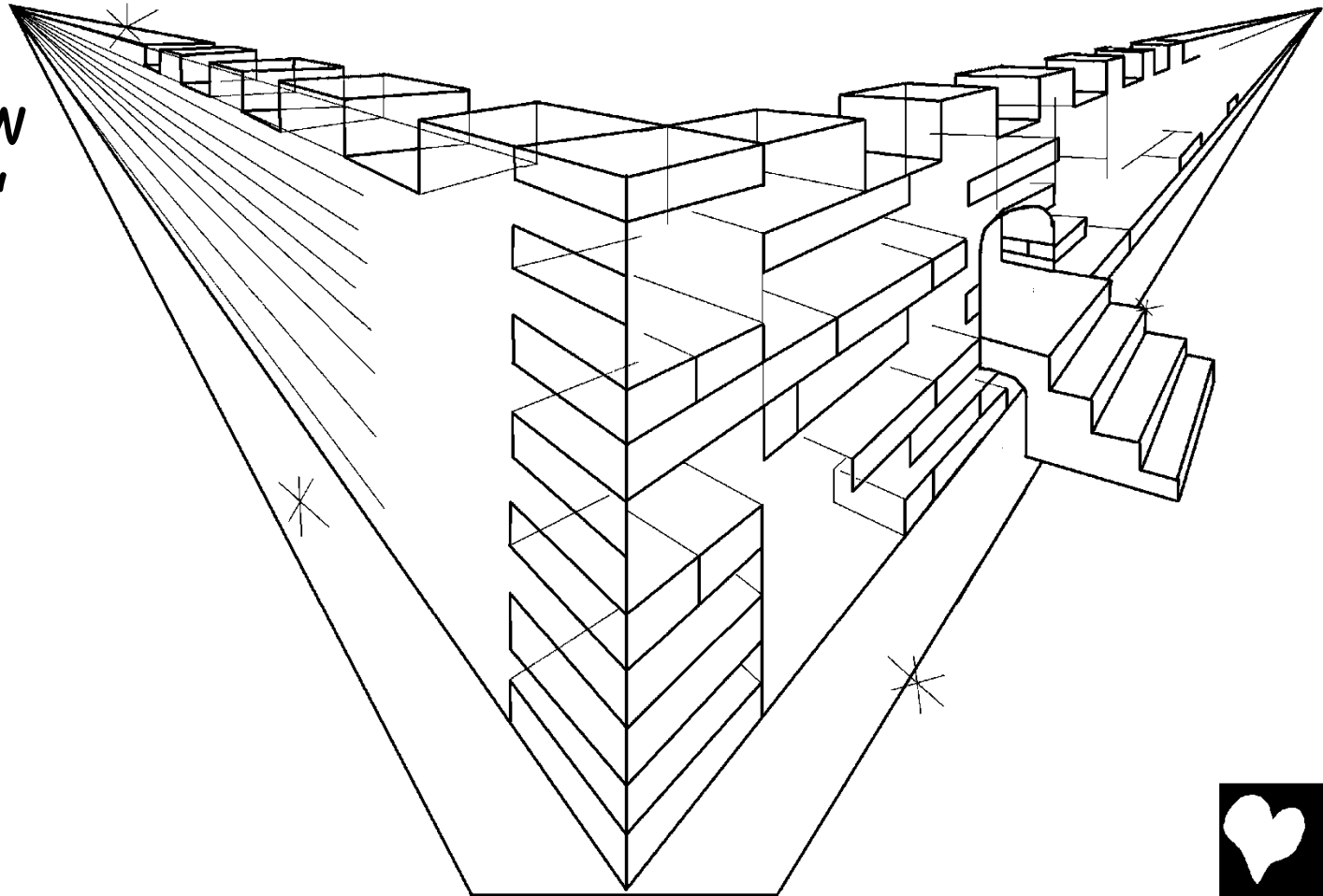

Adon, pyapakita kanak ng malaikat yang tobig na makaatag ng kinabowi na way kataposan na yang katinaw sinyan magonawa ng kristal aw yang pyagasikunan adto sang ingkodanan ng Tohan aw yang Karniro.



Yan na syodad di oman magakinaanglan ng allag ng suga atawa bowan kay kyakaallagan yan ng dakowa na kasiga ng Tohan. Aw yang Karniro magonawa ng ilawan sinyan.



Awgaid di makasuud sinyan na syodad yang maskin sino na dili ng sotti, mga otaw na yagainang ng kamasiyatan atawa mga bakakun.

Yang makasuud gaid sinyan na syodad yang mga otaw na yang ngaan nilan yamakasorat sang libro ng Karniro na ansan yamakalista yang mga otaw na yatagan ng kinabowi na way kataposan.



“Agarisan da nan yang kariko ng lowa nilan. Di da silan amatay atawa amarido, di da silan magatiyao atawa amasakit kay yamawaa da yang ona na kabutang nilan.”



Way maskin ono na ikitaun ansan na syodad na yaharam ng Tohan. Iyan san yang ingkodanan ng Tohan aw yang Karniro aw yang mga sogowanun nan magasambayang kanan. Makita da nilan yang parangay ng Tohan aw adto sang guya nilan yamakasorat yang ngaan ng Tohan.



Adon, kikita ko yang kariko ng mga patay, mga ilado aw dili ng ilado na yanagindug sang adapan ng ingkodanan. Ansinyan byoboklad yang mga libro aw byoboklad oman idtong libro na ansan yamakalista yang ngaan ng mga otaw na yatagan ng kinabowi na way kataposan. Na, yokoman da yang kariko ng mga patay sobay sang ininang nilan na yamakasorat adto sidtong mga libro.

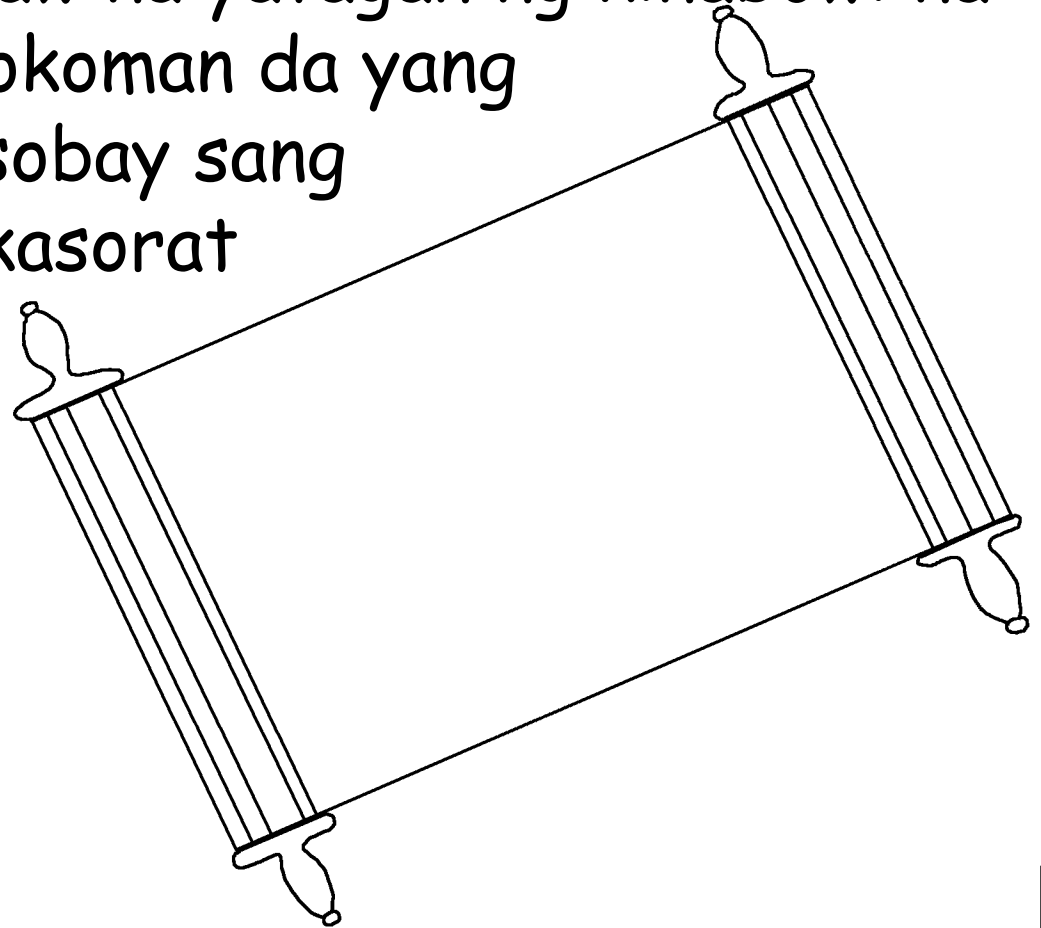

Aw yang kariko ng mga otaw na yang ngaan nilan wa akasorat sang libro na ansan yamakalista yang mga otaw na yatagan ng kinabowi na way kataposan, titimbag oman silan adto sang atoon.

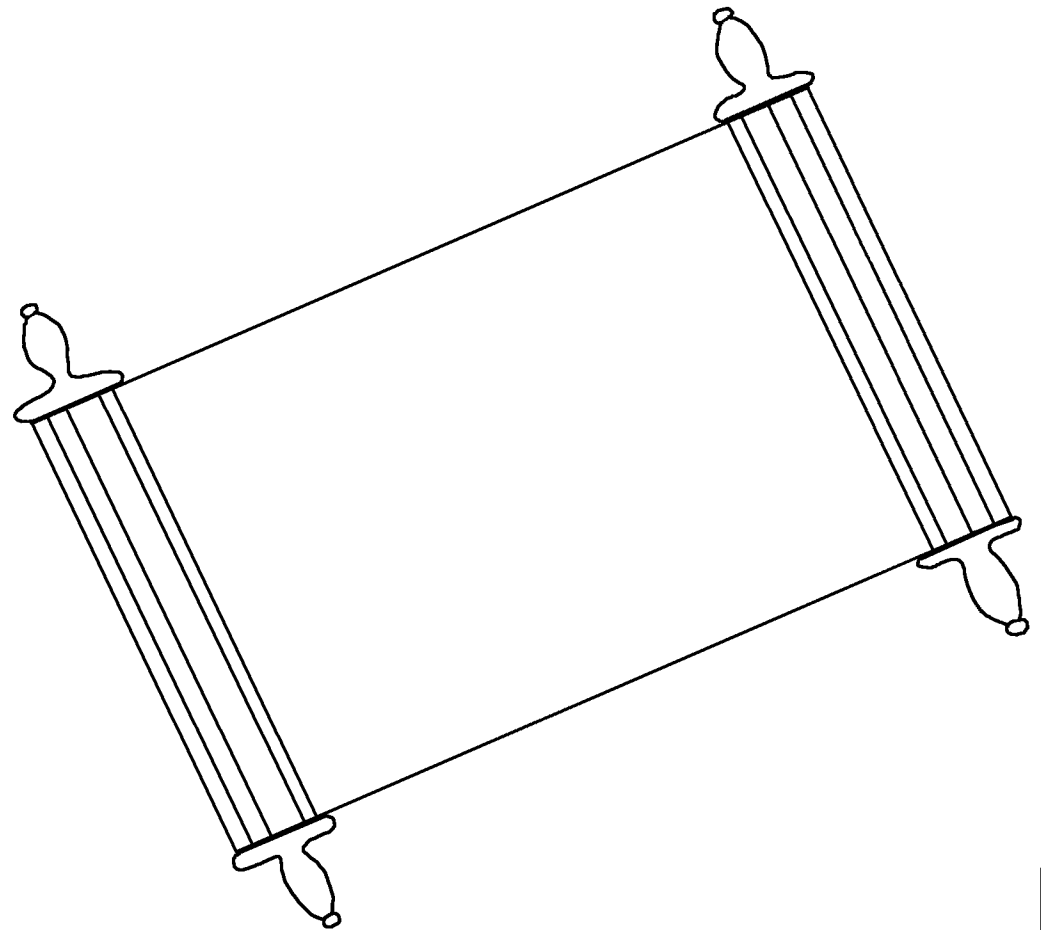

Ansinyan yagalaong yang Nyawa ng Tohan aw yang bobay na akawinun, "Adi kaw!" Aw yang kariko ng yamakadungug sinyan magalaong oman, "Adi kaw!" Sino-sino kamayo yang yamalangga aw marim maginum, dood kamo aw inum kamo ng tobig na

makaatag ng kinabowi na way

kataposan kay painumun kamo ng way bayad.

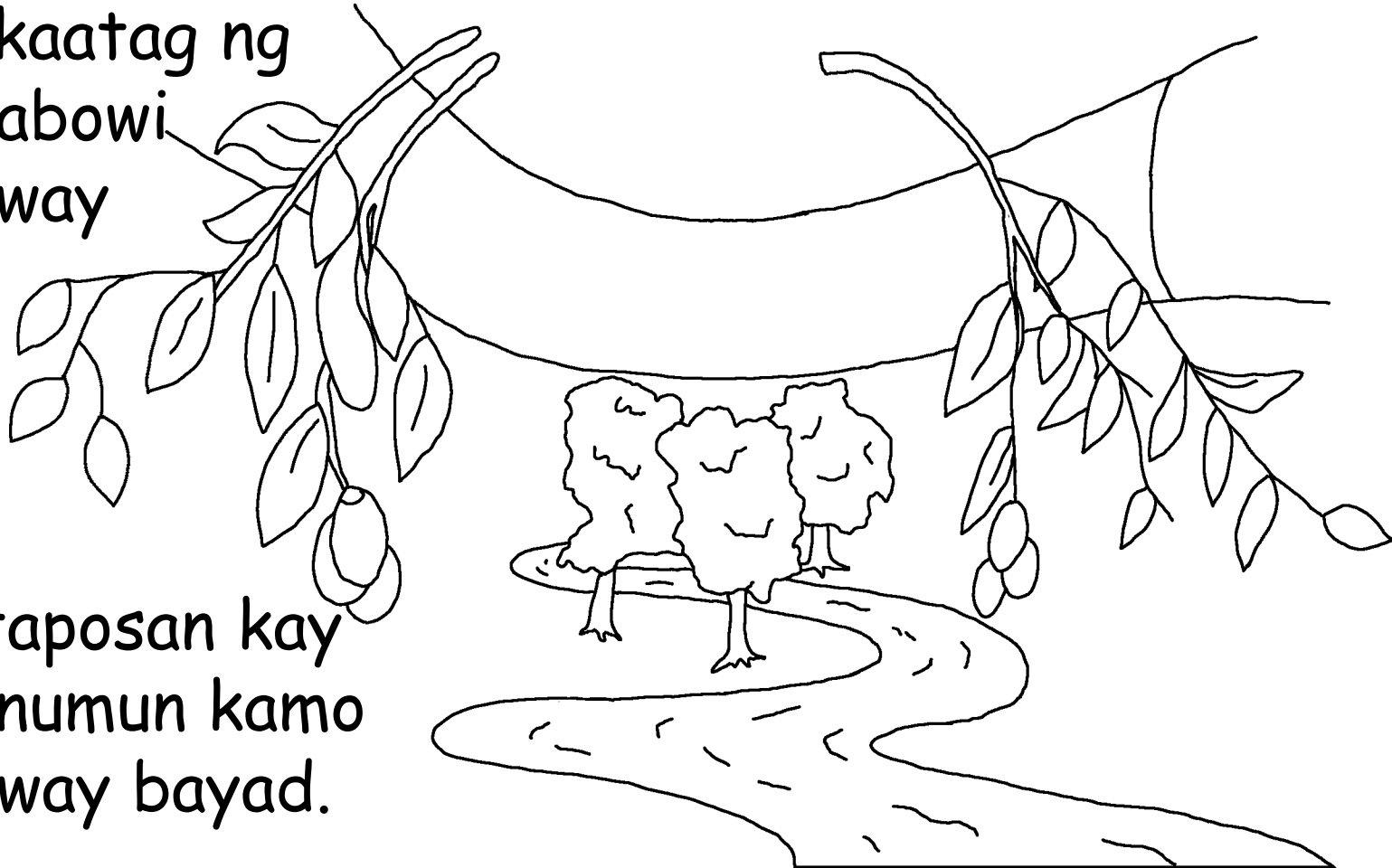

Sabap sang dakowa na looy ng  
Tohan sang manosiya yatag nan  
yang tamisa na Anak nan kay  
antak sino-sino yang amangintoo  
kanan di amanarka, awgaid  
akaonan yan ng kinabowi  
na way kataposan.



Roma 3:23 Kay yang kariko ng manosiya yagapakadosa aw yagapakawat sang Tohan kay wa silan makatoman sang kahanda nan kanilan.

Roma 6:23 Kay yang bayad sang kadosaan yang kamatayun. Awgaid yang atag ng Tohan yang kinabowi na way kataposan sabap kang Isa Almasi na kanatun Tagallang.

Hibrani 9:27 Na, kahanda ng Tohan na amatay yang manosiya ng makaisa aw pagkatapos san hokoman silan ng Tohan.



Ipisos 2:8,9 Kay, idto sagaw, sabap sang looy ng Tohan yamallowas kamo aw sabap oman sang pagpangintoo mayo sang Almasi, aw dili sabap sang sarili na pagpaningkamot mayo. Yang kalowasan yatag kamayo ng Tohan. Agaw, way sino-sino na makapaambog kay yang kalowasan dili bonga ng ininang mayo.

Roma 10:9,10 Kong magalaong kaw na si Isa yang Tagallang, yang Dato na Labi na Mabarakat, aw iklas yang pagpangintoo mo na byobowi oman yan ng Tohan, amalowas kaw sikun sang mga dosa mo aw amasorga kaw. Kay amponon aw atarimaun ng Tohan na matorid yang sino-sino na iklas yang pagpangintoo nilan. Aw sabap sang paglaong nilan na yamangintoo silan, amalowas silan.



Yahiya 3:16,17 Sabap sang dakowa na looy ng Tohan sang manosiya yatag nan yang tamisa na Anak nan kay antak sino-sino yang amangintoo kanan di amanarka, awgaid akaonan yan ng kinabowi na way kataposan. Kay pyapadaa ng Tohan yang Anak nan adi sang donya dili antak hokomon yang manosiya na isiksaun awgaid antak malowas silan sabap kanan.

1 Yahiya 5:11-13 Aw yani yang pagpangimunna ng Tohan na yatagan nan kita ng kinabowi na way kataposan aw yani na kinabowi iyan sang kanan Anak. Agaw, sino-sino yang yatarima sang Anak ng Tohan, kyakaonan ng kinabowi na way kataposan. Awgaid sino-sino yang wa magatarima sang Anak ng Tohan, waa ansan kanan yang kinabowi na way kataposan. Na, syosorat ko yani kamayo na yamangintoo sang Anak ng Tohan antak mayo katigaman na aon kinabowi mayo na way kataposan.



Yahiya 14; 2 Korinto 5; Pyapakita 4, 21, 22

Storyline by: Edward D. Hughes

Illustrated by: Lazarus  
and Alastair Paterson

Adapted by: Sarah S.

Kalagan, Eastern Bible (kqe) © 2012, Wycliffe Bible  
Translators, Inc. All rights reserved.

<https://live.bible.is/bible/KQEBLI/MAT/1>

©2025 Bible for Children, Inc.

[www.M1914.org](http://www.M1914.org)

[www.bibleforchildren.org](http://www.bibleforchildren.org)

