

www.BibleForChildren.org



Jon 14



Yesumi nipuna disaipel alinu-para talo: Nimina lo
robaa-para kone adaapu nasuma kedaame komape
kone page nasalepape. Nimimi Gote madaa kone
rulaoma ni madaa page kone rulaalepape.



Naa Aapana ada adaapu aaya-le nimina ada robe
ameke puma kiritao saata palua. Neme makirae agale
nalagialo. Nimina pirape su puma makiritaoma sumare
nimi mulalo epalua. Go pea-le naa raapu piramina.



Ni Jon-re nimina ame ria piru aayo. Ni Yesu raapu
piruma nimi raayome kedaa riamina. Go puma
naaGote-na Yapi Di-na piruma naa raayo

komea-para puma kedaa epe-rupa ria
piramina. Neme abalade

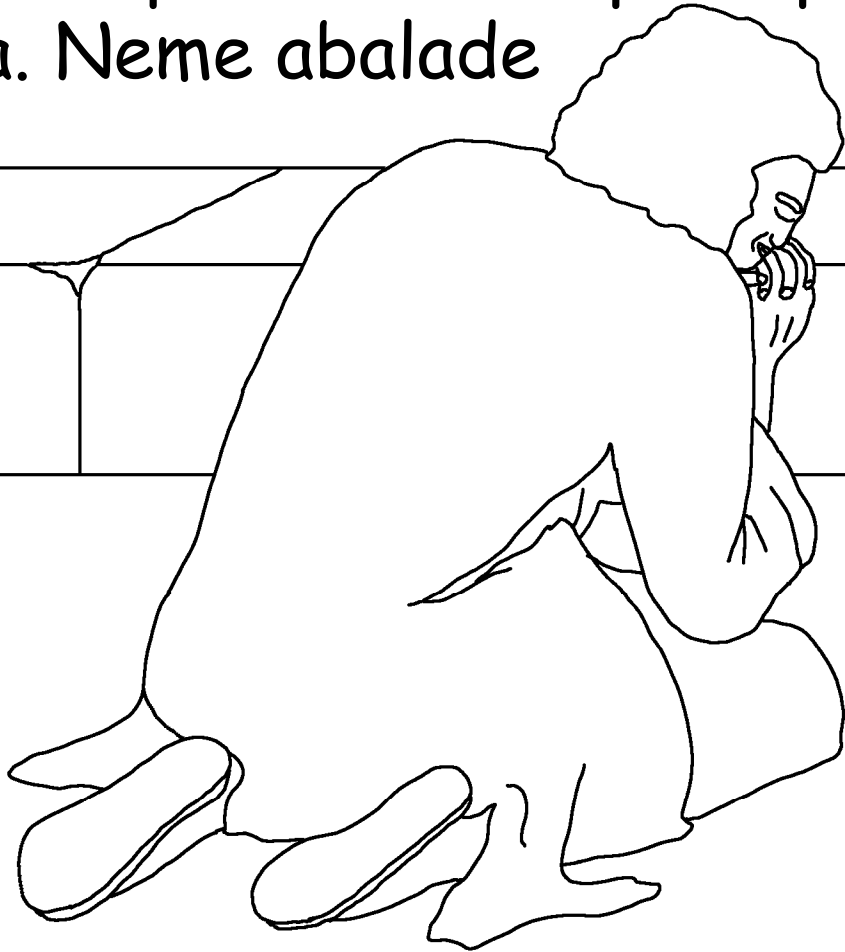

Gote-na agale
lakeloma neme
Yesumi mea
waalisade agale
lagelisuade.



Go raburi wagepu Holi Spirit ni piri-para ipuma puri
gisa. Go pisa pare so yaa-para pirape siaa king meda
wisa ali meda go madaa pirisa-daa adisua.

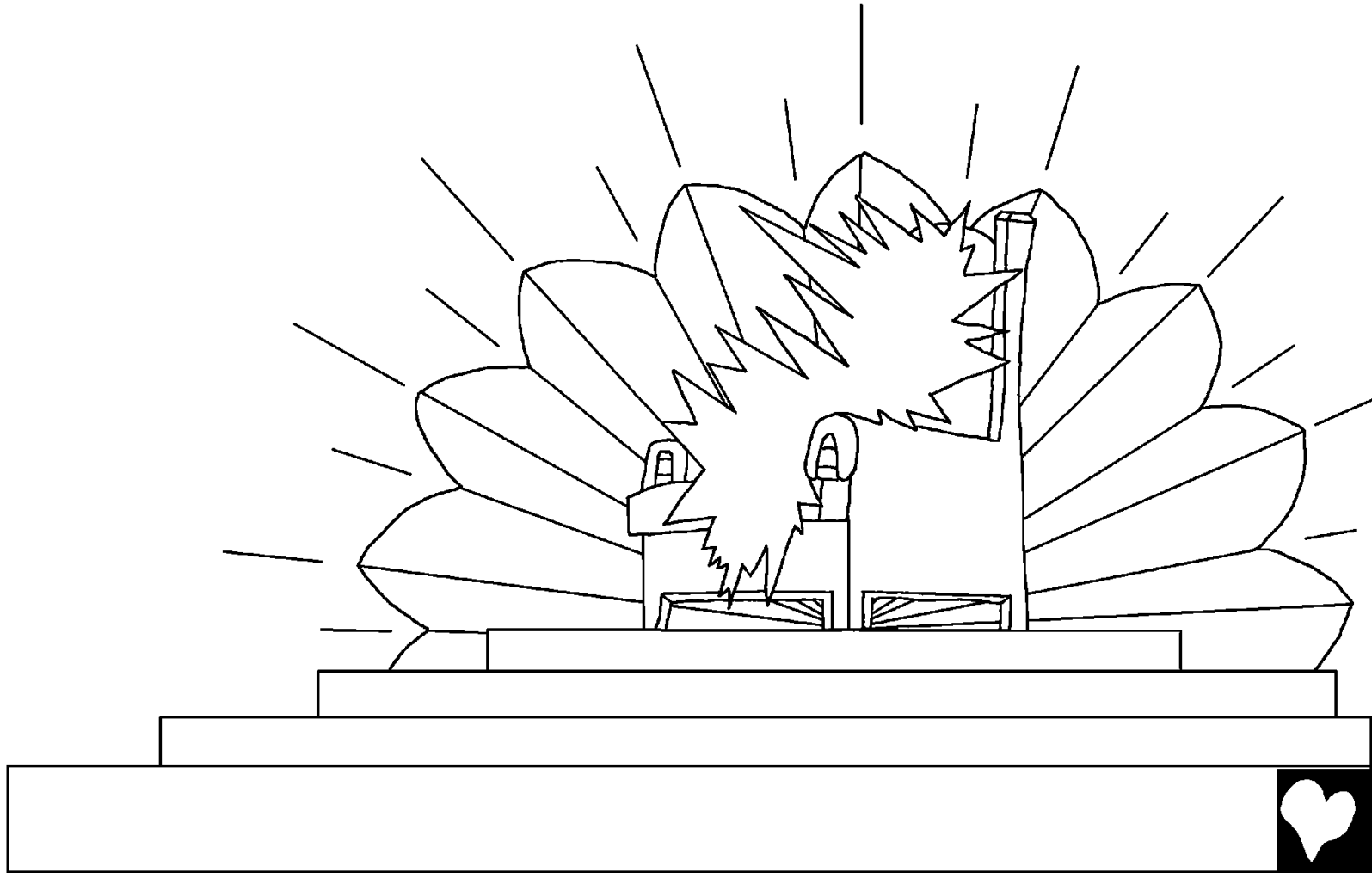

Go rabu neme so yaa-para piri ele raayo-para su
kamaa piri ele raayo-para su ru-nane piri ele page
go ele raayona agale pagisua. Gore
nimu raayome yaaloma go-rupa
lisimi: Gote-re Mudu Ali siaa king
madaa pia-le nipuna sipsip si page
Nipu laapome adaa bi-para bi
minasaape
kone-para epe
paanapuri-para
Orapuri
raayo-para
ade abuna
yaalo muaaepe
lisimi.

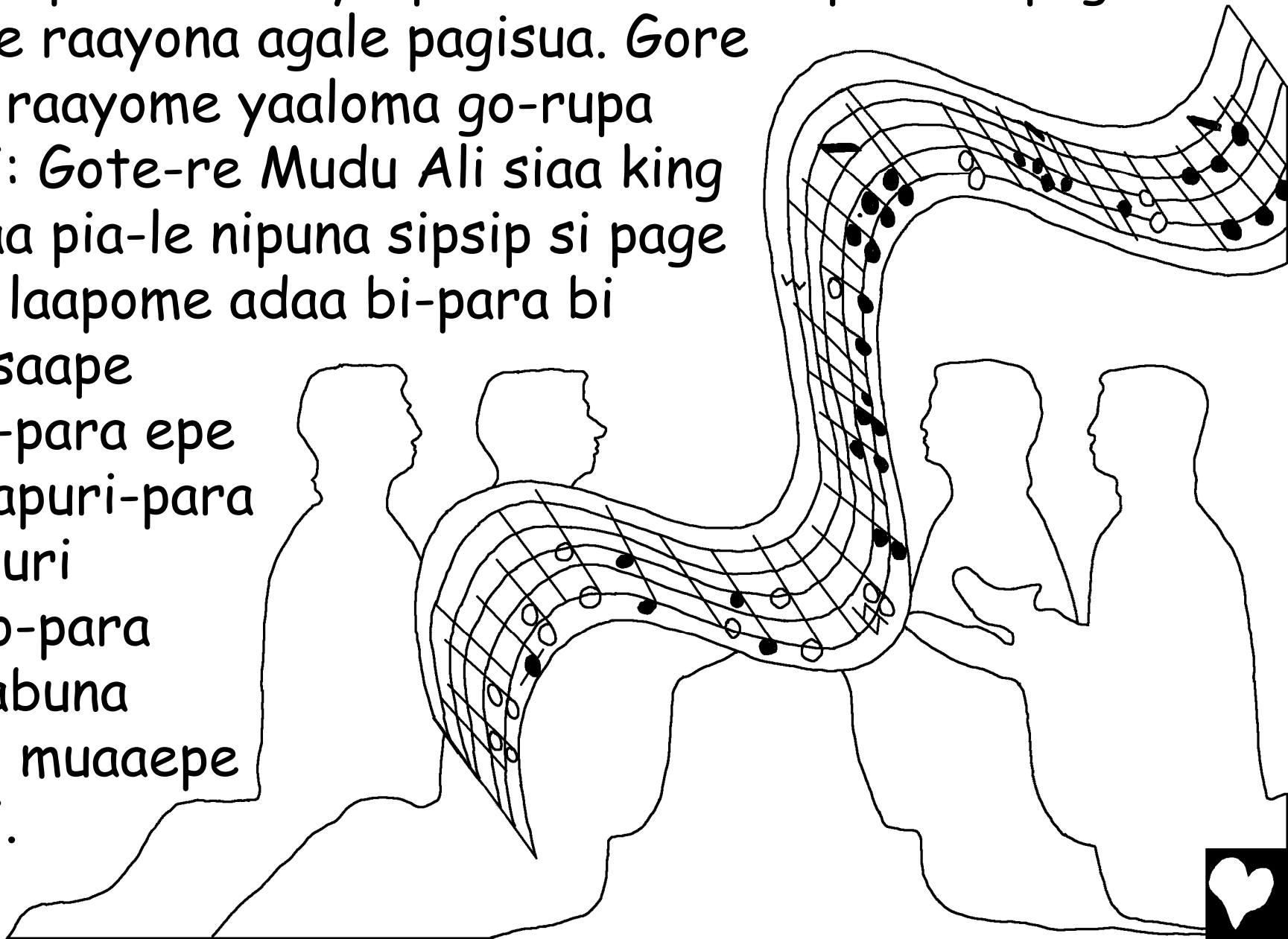

Go puma neme kagaa opaliade epe Jerusalem su-para
siti adisua. Go adisua rabu kagaa adare-re Gote-na su
giyoma su kamaa ipisa. Gore Jerusalem su-para siti
nipumi au ora epe meda puma saasa. Go auri nogonumi
ali polalo raana waru komoma au epe-rupa peme-rupa
mada puma

Jerusalem
kagaa go ipisa.
Go rabu agale
meda mo ali mudu
pirape siaa king
wisa-para puri paloma
go-rupa lisa: Pagalepa.

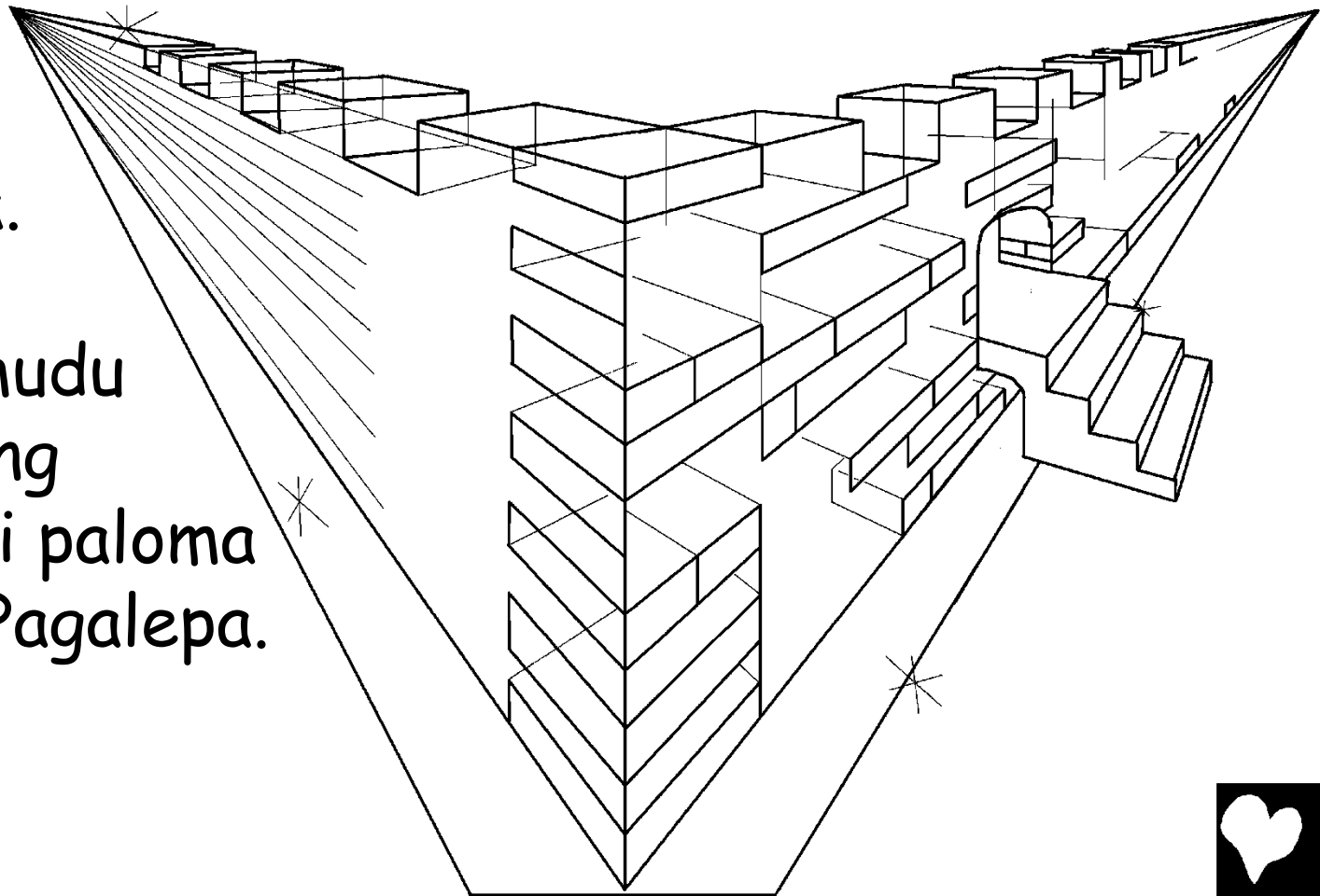

Abiri Gote-na kagaa adare-re nipuna enaalinu raapu aaya. Go pea-le nipu nimuna rikirana salia rabu nimi nipuna ruru enaali piralimi. Gore Gote nipu nimu raapu piralia-pulu ora nimuna Gote komea raapu piralimi.

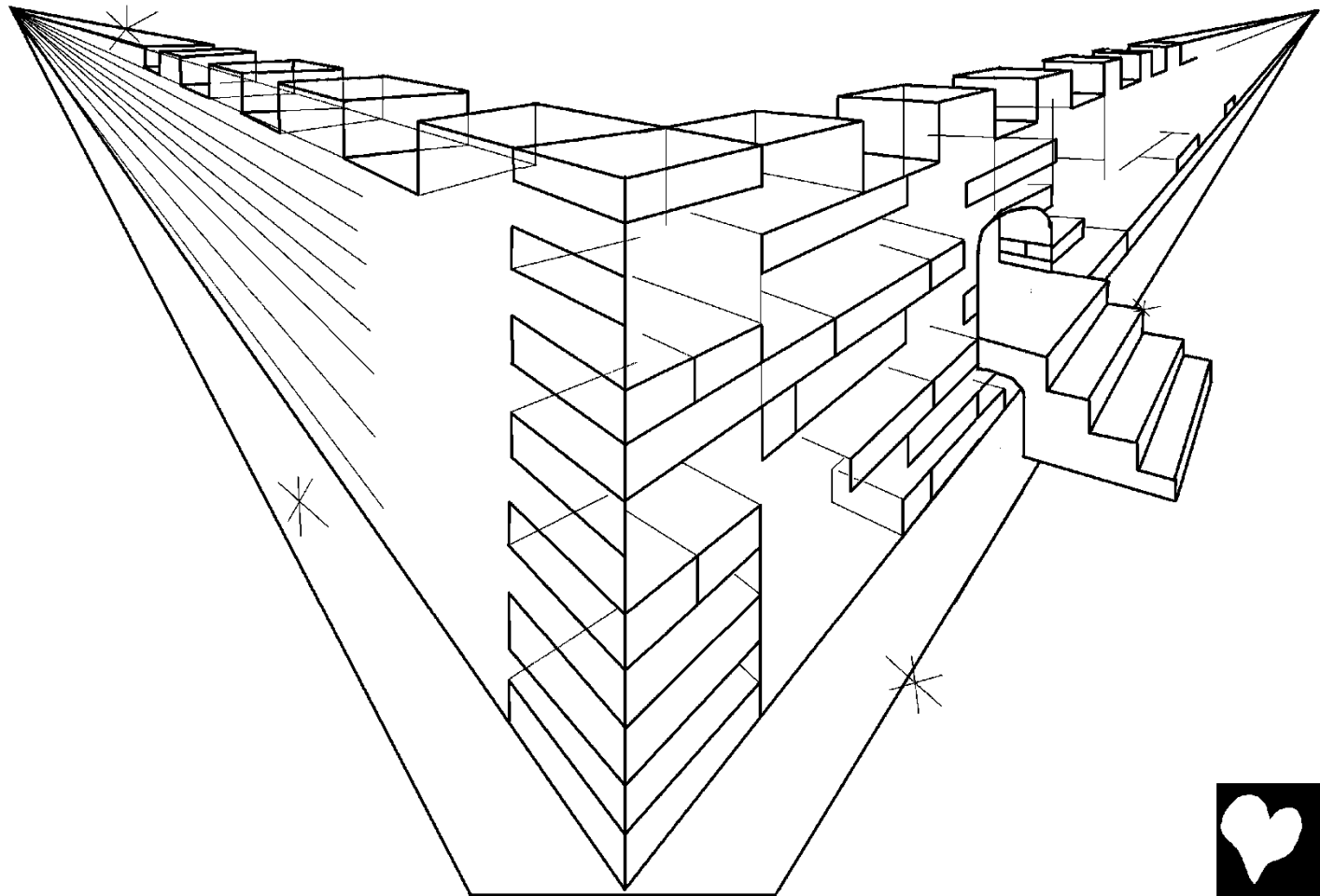

Go puma mo ensel-me ora epe pupulae ipa meda
waalisa. Go ipare wasupa-rupa lepo lepo palai adisua.
Go ipare Gote-para sipsip Si laapona Siaan King
rolo-para yokoma ipuma lisanare enaalinu kagaa
mapiraape ipa yade lo lagisa.

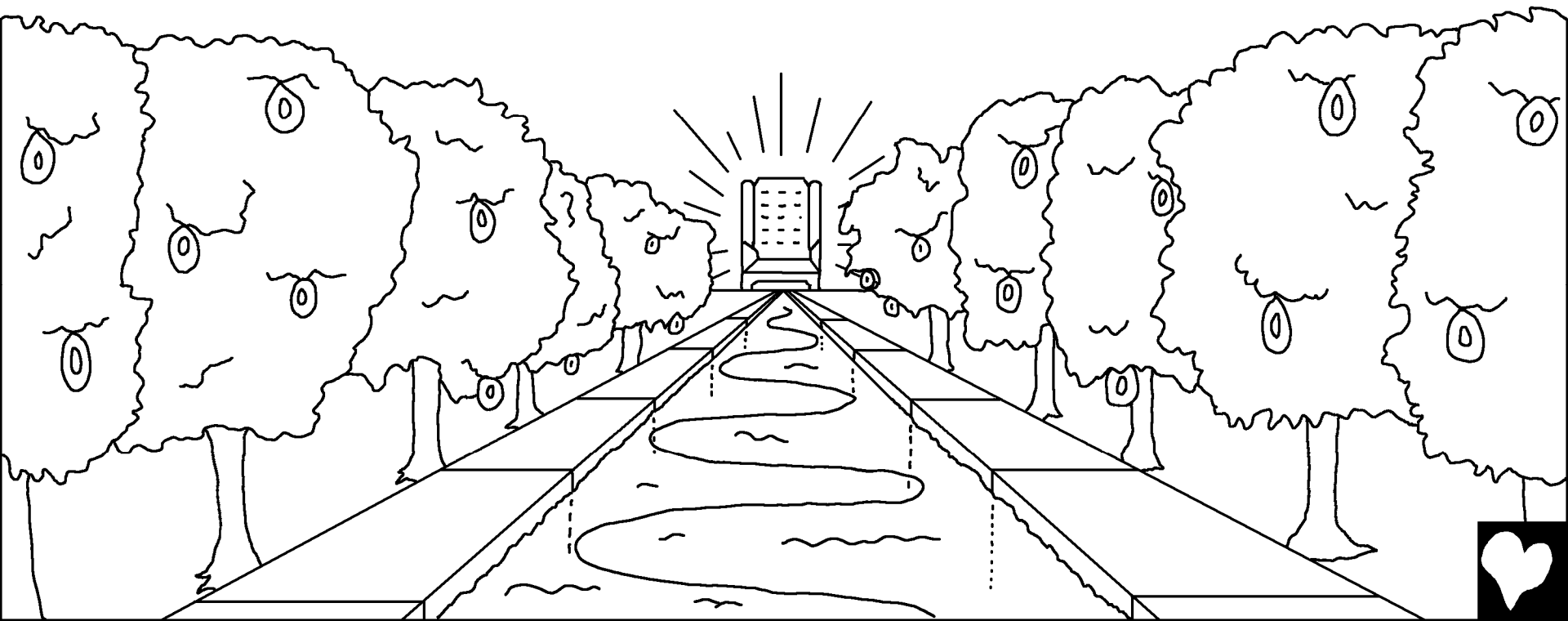

Go adare-parare naare kasua laaapo narooaya pare
Gote nipuna epe paana purimi ma-aulaomaa rooaya
lisa. Go page sipsip mena Simiri go adare-na lam-me
pea-rupa roalia.

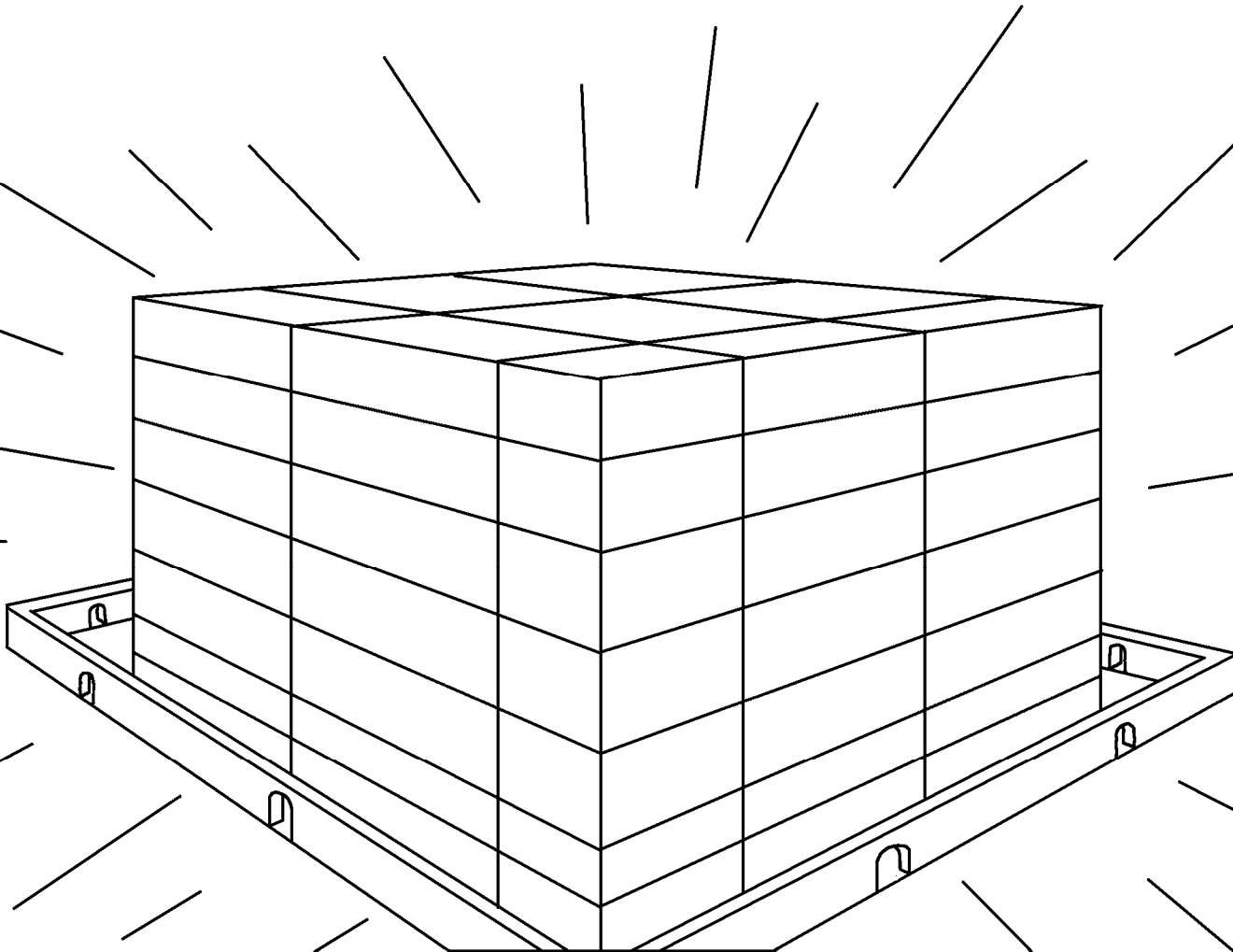

Go palimi pare koe koto pi elenu-para koe ele puma
yala mapolaateme enaalinu-para makirae agale le
enaalinu-para go raayore adare
ru-nane mada na-epa
kodobalimi. Gore ora
mada dia yapare mo
sipsip Simi enaali
medalomana biri ade
abuna epe-rupa pirape
buk madaa abala lu
wisa-pulu go enaalinu
komeare go adare-para
mada puma kodobalimi.



Go rabu nipumi nimuna lo pimi
re ipa raayore dia yaalia. Go
puma enaalinu nimu wala
nakomoma lo robaa-para kedaa
page wala namealimi. Go pumare
nimumi re page wala mada
nateme. Go puma nimumi radaa
page wala nanalimi. Go puma
abalana su yaa laapore ora dia
yaalia lisa.



Go puma ele raayo Gote-me ralu rubalia rabu koe
elenu meda go adare-para wala nasalia. Gore
Gote-para Sipsip Mena Si laapona ali mudu pirape
siala king-ri go ada re-para salia. Go puma Gote nipuna
kogono enaalinumi
nipuna bi minasaoma
beten lalaalimi.
Go puma naame
nipuna le agaa
adoma nipuna
biri naana eno
madaa lu
sabaalia.



Go puma neme abala kome enaali raayo adisua. Go puma mo enaali naralinu-para mudunu-para ali mudu pirape siaa wia-nane rekaasimi. Go puma mo siaa madaa piri alimi buk lobenalo maa kalisimi. Go puma ora epe-rupa kagaa piramala pope buk page mea lobesa. Go pumare nipumi buk-nupara nimuna pisimide kogono adoma rumaasa.

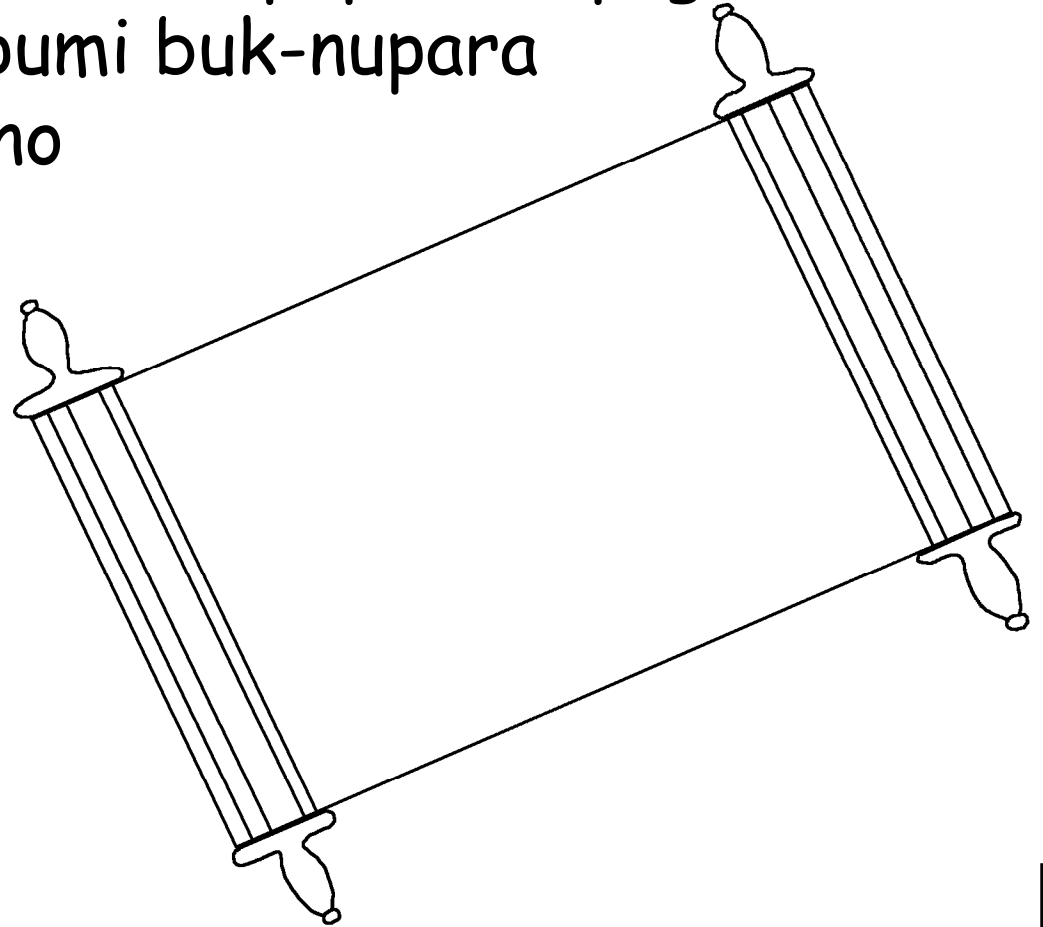

Go rabu mo abala kome enaali raayo kose naloma yoto rumaasa. Go pumare kose pagape alimi enaali raayona binu epe buk madaa nasalia-daare nipumi go enaalinu naaku repena sulaa rea-para maa lopalia.

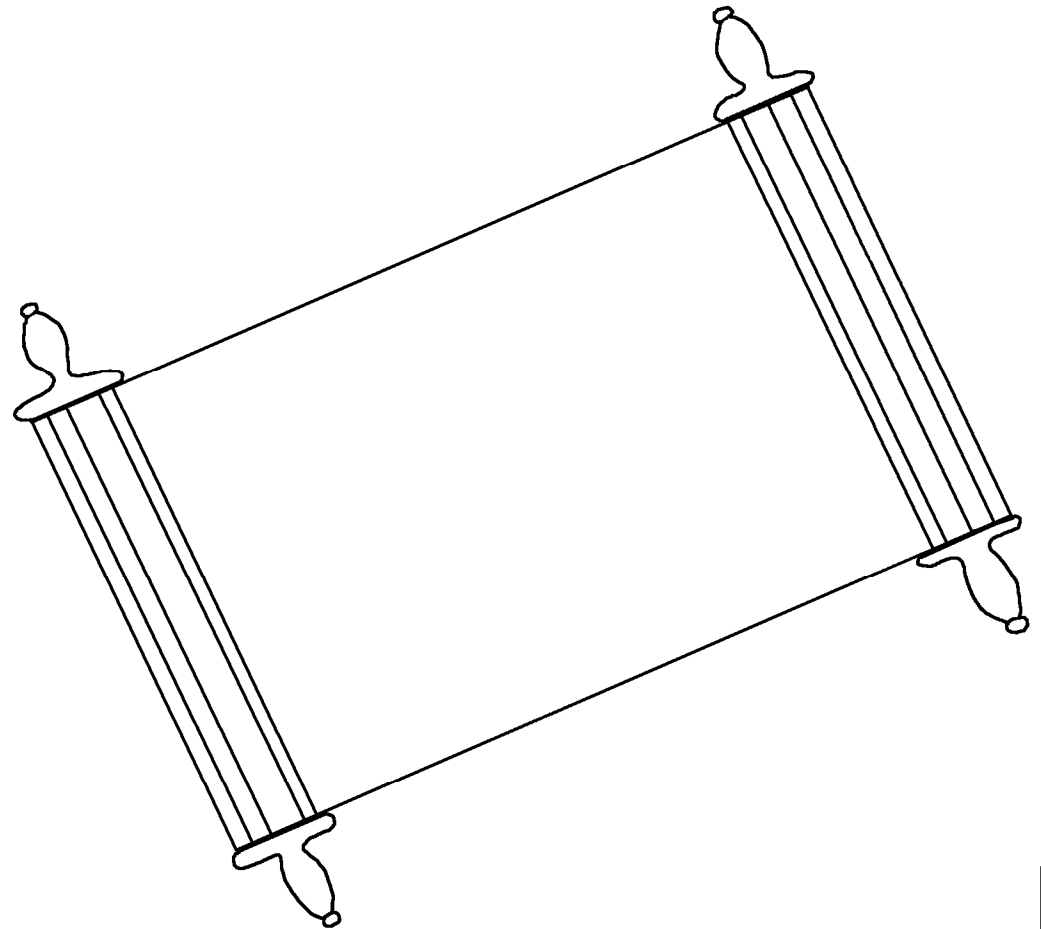

Gore Holi Spirit-para mo sipsip mena si laapome talo:
Nere nipu lisipi. Go pea-le enaali raayome go agale
pagalimiri nimu page epalimi. Go enaali raayome ipa
nalame komalimiri epe ipa nola baina lamina. Go puma
enaali raayome go ade abuna kagaa pirape ipa nolalo
palimiri go
ipa epa
nalepape.



Gore Gote-me su kamaa piri enaali
raayo madaa ranaame komisa-pulu
ora nipuna Si komea mea rapasa. Go
pea-le enaali raayome ni madaa kone
mapiraalimiri nimu ora
nakomalimi pare ade
abuna kagaa
piramala
palimi.



Rom 3:23

Enaali raayome pupitagi neme-pulu nimumi Gote-na ade abuna mapiraape kone na-ademe.

Rom 6:23

Pupitagi ne konemere enaalinu rudu katea rabu komape ele mealimi. Go pea pare Gote-me kode pa gi elemere naana Mudu Ali Yesu Keriso raapu ade abuna kagaa pirape kone mealima.

Hibru 9:27

Enaali raayore komea rabu komoma wala werepe Gote-me enaali raayo kose madaa epena tea.

Efesus 2:8,9

Gote-me nimi epe raba meape kone gisa-pulu nimimi Keriso madaa kone rulaoma ade abuna kagaa piraamala palima. Go konere naame pula pisima-rupadaa dia pare Gote-me naa pa kode gisa. Go puma naame ele meda mada napalima-pulu naana bi namakuaasaamina.



Rom 10:9,10

Naame gu-rupa mogelema: Nimimi nimina agaleme Yesu ora naana Mudu Ali loma nimina lo robaa-para Gote-me Yesu tapa-para marekaasa-le kone rulalimiri ade abuna kagaa piramala palima. Gore naana lo-parare kone rulaema-pulu Gote raapu naa redepo le enaalinu pima. Go puma naana agaleme Yesu ora Mudu Ali tema-pulu ade abuna kagaa piramala palima.

Jon 3:16,17

Gore Gote-me su kamaa piri enaali raayo madaa ranaame komisa-pulu ora nipuna Si komea mea rapasa. Go pea-le enaali raayome ni madaa kone mapiraalimiri nimu ora nakomalimi pare ade abuna kagaa piramala palimi. Go pea-pulu Gote-me ni nipuna Si su kamaa kose agale pagenalo namuma rapasa. Dia, pare enaali epe pora mea walenalo mea rapasa.



1 Jon 5:11-13

Gore ora agale Gote-me naa laguaayare go-rupa pagamina: Gote-me abalade naa ade abuna pirape kone gisa Go-rupa pisa-le ade abuna kagaa pirape konena re-re naa nipuna Si Yesu raapu piruma mu aaema. Enaali raayome Gote-na Si madaa kone rulaoma pogaluma pitimi-daare nimumi go ade abuna kagaa pirape kone mu aaeme. Go pea pare enaali raayome Gote-na Si madaa kone narulaoma nipu raapu napiruaemere nimu ade abuna nipu raapu napiralimi. Neme go pepa nimimi adaliminalo rapaatore nimimi ade abuna Gote raapu piruma makuaaliminalo rapaato. Nimimi Gote-na Si Yesuna bi madaa kone rulaeme-pulu ade abuna kagaa pirape-ai re adaliminalo rapaato.



Jon 14; 2 Korin 5; Paga 4, 21, 22

Storyline by: Edward D. Hughes

Illustrated by: Lazarus
and Alastair Paterson

Adapted by: Sarah S.

Kewa, East NT (kjs) © 2004, Wycliffe Bible
Translators, Inc. All rights reserved.

<https://www.bible.com/bible/1012/MAT.1>

©2026 Bible for Children, Inc.

www.M1914.org

www.bibleforchildren.org

