

Jon 14

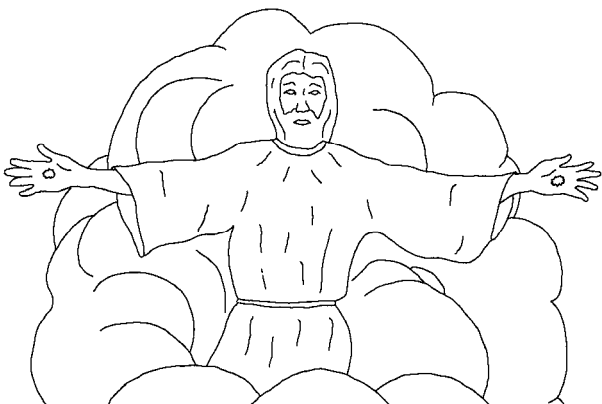

Yesumi nipuna disaipel aanu-para lalo: Nimina robaa-para kone adaapu nasua kedaame omape kone page nasalepape. Nimimi Gote madaa kone rulaawa ni madaa page kone rulaatepape.



Nina Aapana ada adaapu aaya-ga nimina pirape ada managola saata palua. Neme yaa agaa nalagialo. Nimina pirape su pua managolaawa suare nimi mulalo epalua. Goa pea-ga niaa raapu piramina.

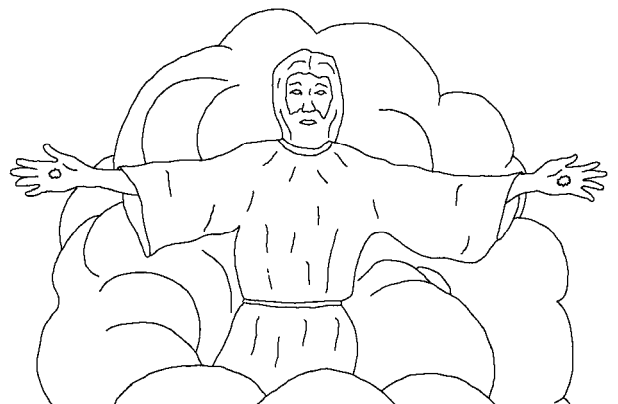

Ni Jon-re nimina ame ria piruaayo. Ni Yesu raapu pirua nimina riaayo-ga rayome kedaa riamina. Goa pua niaa Gote-na yapi Di-na pirua

niaa rayo padane-para pua kedaa epe-rupa ria pirimina.



3

Neme abade Gote-na agaa lakeloa neme Yesumi mea waasade agaa lakesude. Goa pisu pare nimumi ni yada tae aa mapiraawa

solwara rikiraana ae su Patmos-para mea mapiraasa.

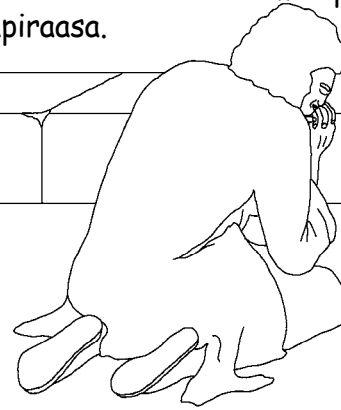

4

Go raburi aipapulu Holi Spirit ni piri-para ipua puri gisa. Goa pisa pare so yaa-para pirape siaa king meda isa pare aa meda go madaa pisrisa-daa adesu.

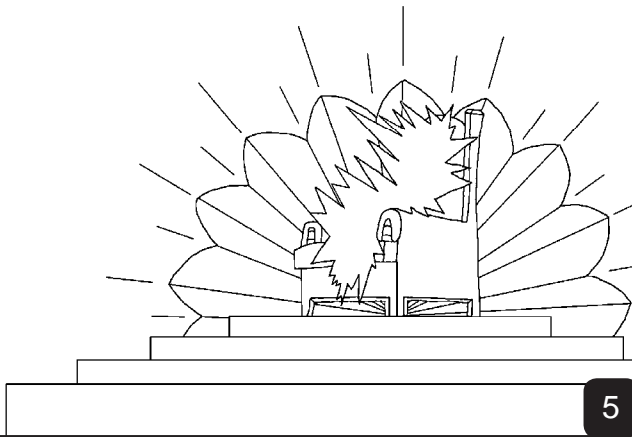

5

Go rabu neme so yaa-para piri oyae rayo-para su amaa piri oyae rayo-para su ru-nane piri oyae page go yae rayona agaa pagesu. Gore nimu rayome yaaloa gupa simi: Gote-re Aa Mudu siaa king madaa pia-ga nipuna sipsip si page nipu laapome adaa bi-para bi minasaape kone-para epe paana puri-para ora puri rayo-para oro yaalo yaalo muape simi.

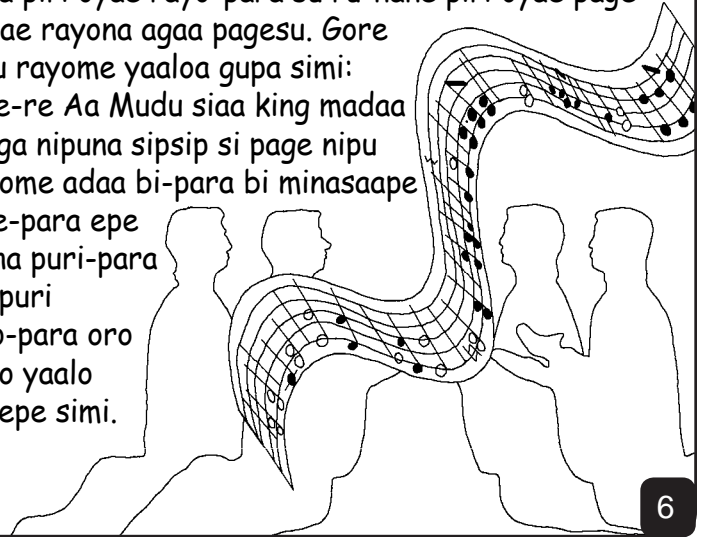

6

Goa pua neme kagaa opaliade epe Jerusalem su-para siti adesu. Go adesu rabu kagaa adaarere Gote-na su gimoa su amaa ipisa. Gore Jerusalem su-para siti nipumi pepena ora epe meda pua sasa. Go pepenare nogonumi aa polalo raana waru omoa pepena epe-rupa peme-rupa mada pua Jerusalem kagaa go plane ipisa.

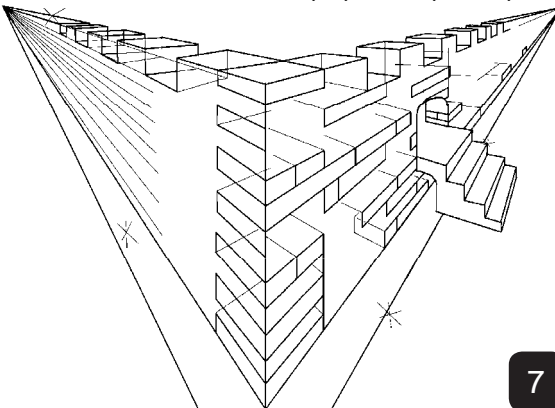

7

Go rabu agaa meda mo aa mudu pirape siaa king isa-para puri paloa gupa sa: Pagalepa. Abiare Gote-na kagaa adaarere nipuna onaanu raapu aaya. Goa pea-ga nipu nimuna rikiraana salia rabu nimi nipuna ruru onaa piralimi. Gore Gote nipu nimu raapu piralia-pulu ora nimuna Gote padane raapu piralimi.

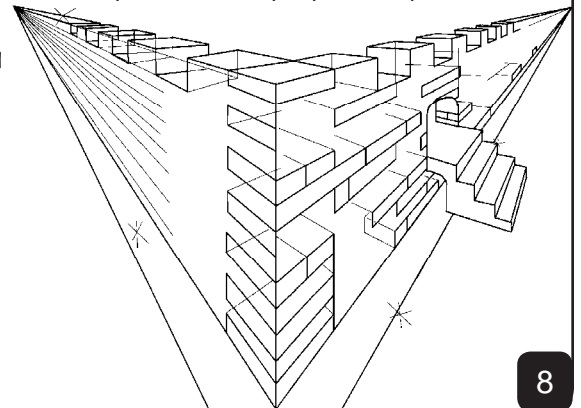

8

Goa pua mo ensel-me ora epe pupulae ipa meda waasa. Go ipare wasupa-rupa lepo lepo yaatae adesu. Go ipare Gote-para sipsip Si lapona king siaa rolo-para yokoa ipua sanare onaanu kagaa mapiraape ipa yade lo lagisa.

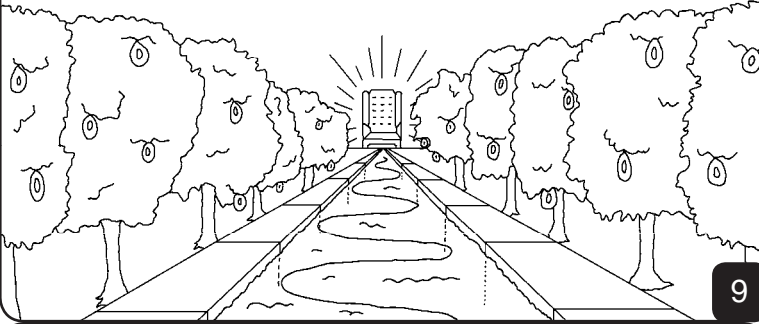

Go adaare-parare naare akua laaapo naroaaya pare Gote nipuna epe paana purimi ma-aulaawa roaawa sa. Go page sipsip mena Simiri go adaare-na lam paa-rupa roalia.

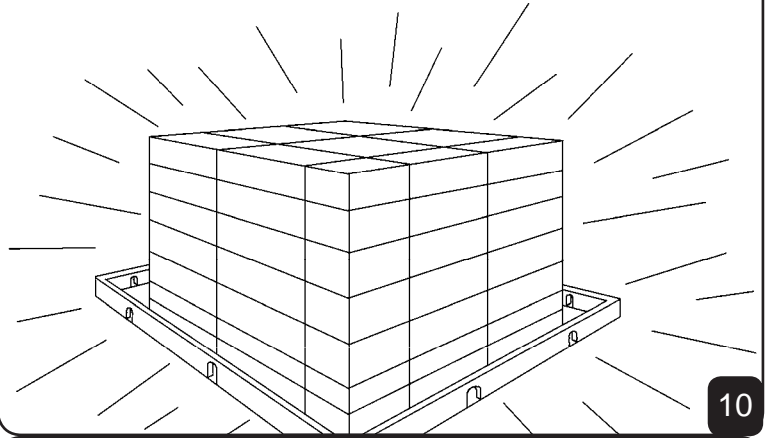

Goa palimi pare wae oto pi yaenu-para wae yae pua yala mapolateme onaanu-para yaa agaa ne onaanu-para go rayore adaare ru-nane mada naepa odobalimi. Gore ora mada dia yapare mo sipsip Simi onaa medalomana biri oro yaalo epe-rupa pirape buk madaa aba tu isa-pulu go onaanu padanere go adaare-para mada pua odobalimi.

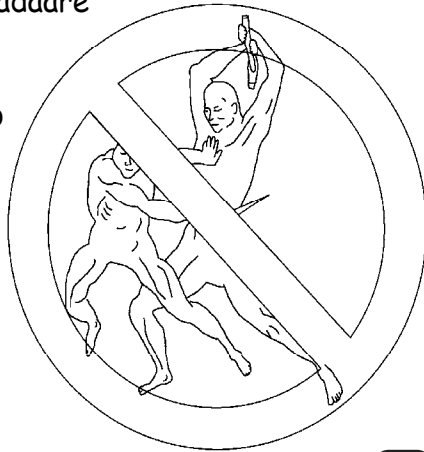

Go rabu nipumi nimuna lo pimi re ipa rayore dia yalia. Goa pua onaanu nimu wala naomoa robaa-para kedaa page wala namealimi. Goa puare nimumi re page wala mada nateme. Goa pua nimumi radaa page wala nanalimi. Goa pua abana su yaa laapore ora dia yalia sa.



Goa pua oyae rayo Gote-me ratu rubalia rabu wae yaenu meda go adaare-para wala nasalia. Gore Gote-para Sipsip Mena Si laapona aa mudu pirape siaa king-ri go ada re-para salia. Goa pua Gote nipuna kogono onaanumi nipuna bi minasaawa beten lalaalimi. Goa pua niaame nipuna ini agaa adoa nipuna biri niaana eno madaa tu saabalia.



Goa pua neme aba ome onaa rayo adesu. Goa pua mo onaa naraanu-para mudunu-para aa mudu pirape siaa ia-nane rekaasimi. Goa pua mo siaa madaa piri aame buk lobenalo mea kasimi. Goa pua ora epe-rupa kagaa piraama laama pope buk page mea lobesa. Goa puare nipumi buk-nupara nimuna pisimide kogono adoa rumaasa. Go rabu mo aba ome onaa rayo koso naloo yoto rumaasa. Goa puare koso pagape aame onaa rayona binu epe buk madaa nasalia-daare nipumi go onaanu naaku repena sulaa rea-para mea lopalia.

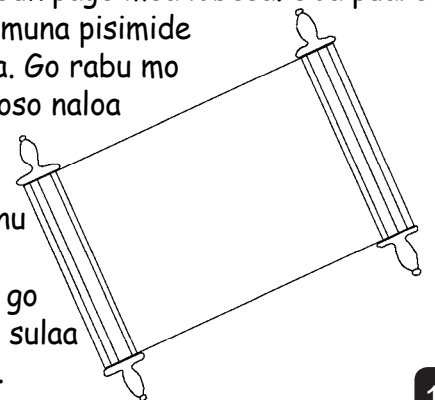

Gore Holi Spirit-para mo sipsip mena si lapome lalo: Nere ipu sipi. Goa pea-ga onaa rayome go agaa pagalimiri nimu page epalimi. Go onaa rayome ipa nalame omalimiri epe ipa nola baina lamina. Goa pua onaa rayome go oro yaalo kagaa pirape ipa nolalo palimiri go ipa epa nalepape.

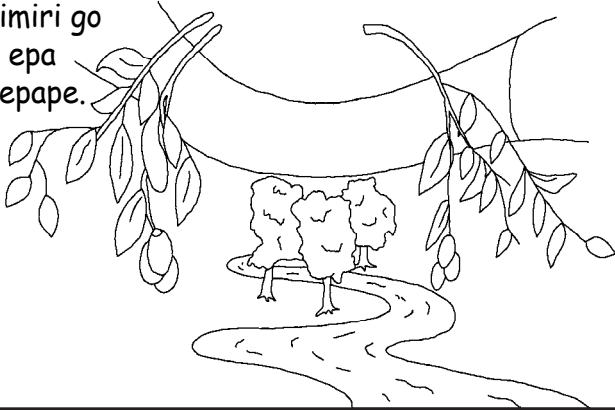

15

Gore Gote-me su amaa piri onaa rayo madaa pedo pu raaname omesa-pulu ora nipuna Si padane mea repasa. Goa pea-ga onaa rayome ni madaa kone mapiraalimiri nimu ora naomalimi pare oro yaalo kagaa piraama laama palimi.

16

Rom 3:23

Onaa rayome pupitagi neme-pulu nimumi Gote-na oro yaalo mapiraape kone na-ademe.

Rom 6:23

Pupitagi ne konemere onaanu yoto katea rabu omape yae mealimi. Goa pea pare Gote-me ode pa gi yaemere niaana Aa Mudu Yesu Krai raapu oro yaalo kagaa pirape kone mealima.

Hibru 9:27

Onaa rayore padane rabu omoa wala orope Gote-me onaa rayo koso madaa epena tea.

Efesus 2:8,9

Gote-me nimi epe raba meape kone gisa-pulu nimimi Krai madaa kone rulaawa oro yaalo kagaa piraama laama palima. Go konere niaame pula pisima-rupadaa dia pare Gote-me niaa pa ode gisa. Goa pua niaame yae meda mada napalima-pulu niaana bi naminasaamina.

17

Rom 10:9,10

Niaame gupa mogetema: Nimimi nimina agaame Yesu ora niaana Aa Mudu loa nimina robaa-para Gote-me Yesu matmat-para marekaasa-ga kone rulalimiri oro yaalo kagaa piraama laama palima. Gore niaana robaa-parare kone rulaema-pulu Gote raapu niaa redepo ne onaanu pima. Goa pua niaana agaame Yesu ora Aa Mudu tema-pulu oro yaalo kagaa piraama laama palima.

Jon 3:16,17

Gore Gote-me su amaa piri onaa rayo madaa pedo pu raaname omesa-pulu ora nipuna Si padane mea repasa. Goa pea-ga onaa rayome ni madaa kone mapiraalimiri nimu ora naomalimi pare oro yaalo kagaa piraama laama palimi. Goa pea-pulu Gote-me ni nipuna Si su amaa koso agaa pagenalo namea rapaasa. Dia, pare onaa epe pora mea wanalo mea rapaasa.

18

1 Jon 5:11-13

Gore ora agaa Gote-me niaa laguayare gupa pagamina: Gote-me abade niaa oro yaalo pirape kone gisa. Gupa pisa-ga oro yaalo kagaa pirape konena re-re niaa nipuna Si Yesu raapu pirua muaema. Onaa rayome Gote-na Si madaa kone rulaawa pogatua pitimi-daare nimumi go oro yaalo kagaa pirape kone muaeme. Goa pea pare onaa rayome Gote-na Si madaa kone narulaawa nipu raapu napiruaemere nimu oro yaalo nipu raapu napiralimi. Neme go pepa nimimi adalimalo repatore nimimi oro yaalo Gote raapu pirua niminaaminalo repaato. Nimimi Gote-na Si Yesuna bi madaa kone rulaeme-pulu oro yaalo kagaa pirapena re adalimalo repaato.

19

Jon 14; 2 Korin 5; Kudiri 4, 21, 22

Storyline by: Edward D. Hughes

Illustrated by: Lazarus and Alastair Paterson

Adapted by: Sarah S.

Kewa, West NT (kew) © 2004, Wycliffe Bible Translators, Inc. All rights reserved.

<https://live.bible.is/bible/KEWPNG/GEN/1>

©2026 Bible for Children, Inc.

www.M1914.org

www.bibleforchildren.org

20