

www.BibleForChildren.org



Yohana 14



“Muleke ukusuvuala mu numbula tsiinyo,
mukumwidika uNgeluve, innyidikagi najyune.
Uvutaamo uvaha mu nyumba jya Daada. tkaale ileke
ukva wu jiliwo, ndalino ndivavulile, manya ndili mu
nzila ukuluta kukvanotsehetsa aponu arakva
unyie.”

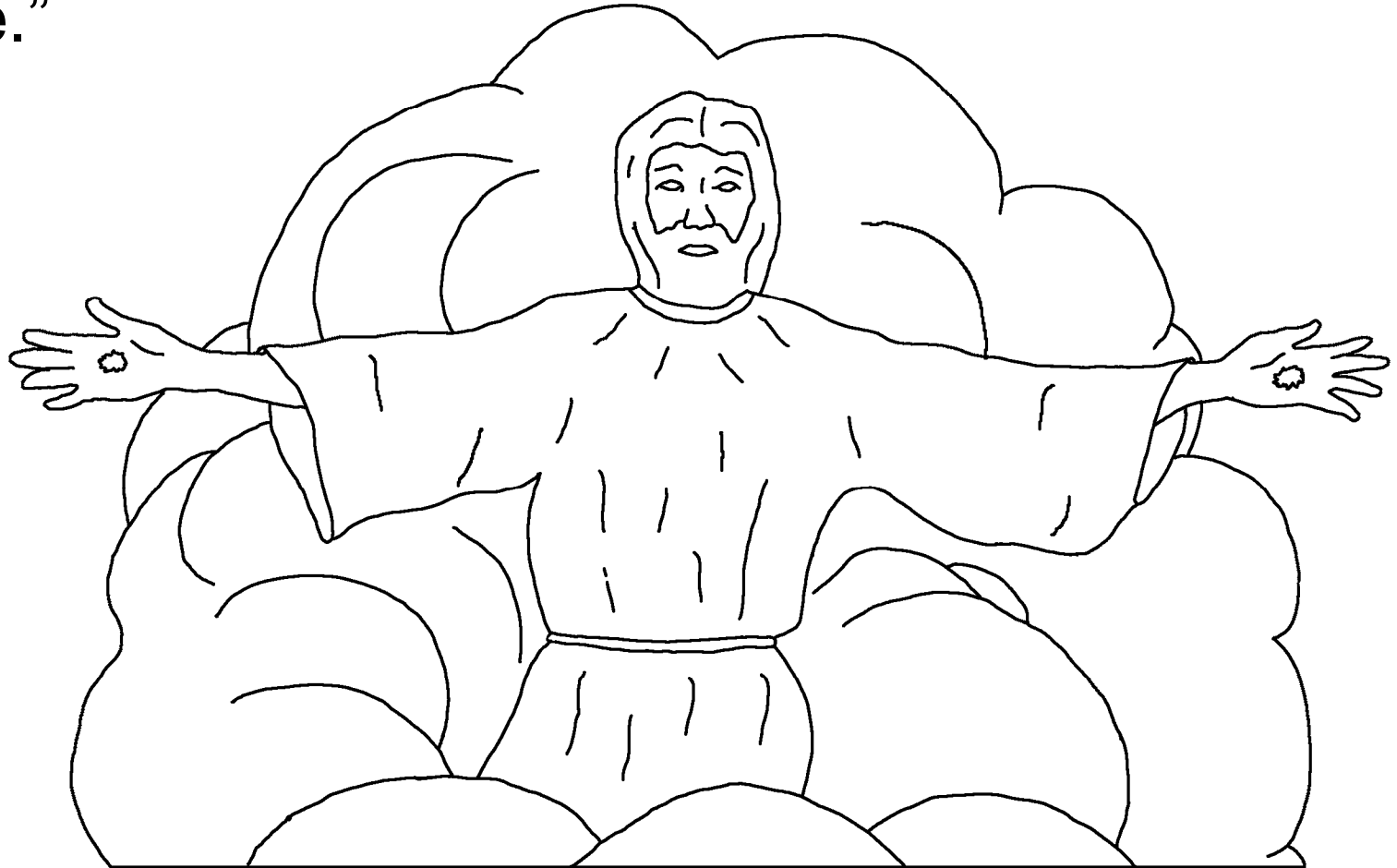

“Wu ndilutle nu kuvanotsehetsa, jundikilivuka ikange kukuvatoola unyie rakuta apoonu urwu ndiiva, najunyie ruw muveetsage paninie nuune.”



Une neene Yohana, ndi mwidikin'jiinyo ikange
neene ndili paninie nūnyie pa kulongwi jya
kankonga uYisu Kilisiti mu vukuvilwa na

mu Ludeeva lwa mwene
na mu lwijumilitso.



Ndyakungilwe mu kilunga ikili pagati pa Nyanza
ikitambulwa Patimo pakuba ndyalum bililaga
ilimenyu lya Ngulave na kwoleletsa

ikulongwi tsa Yisu Kilisiti.

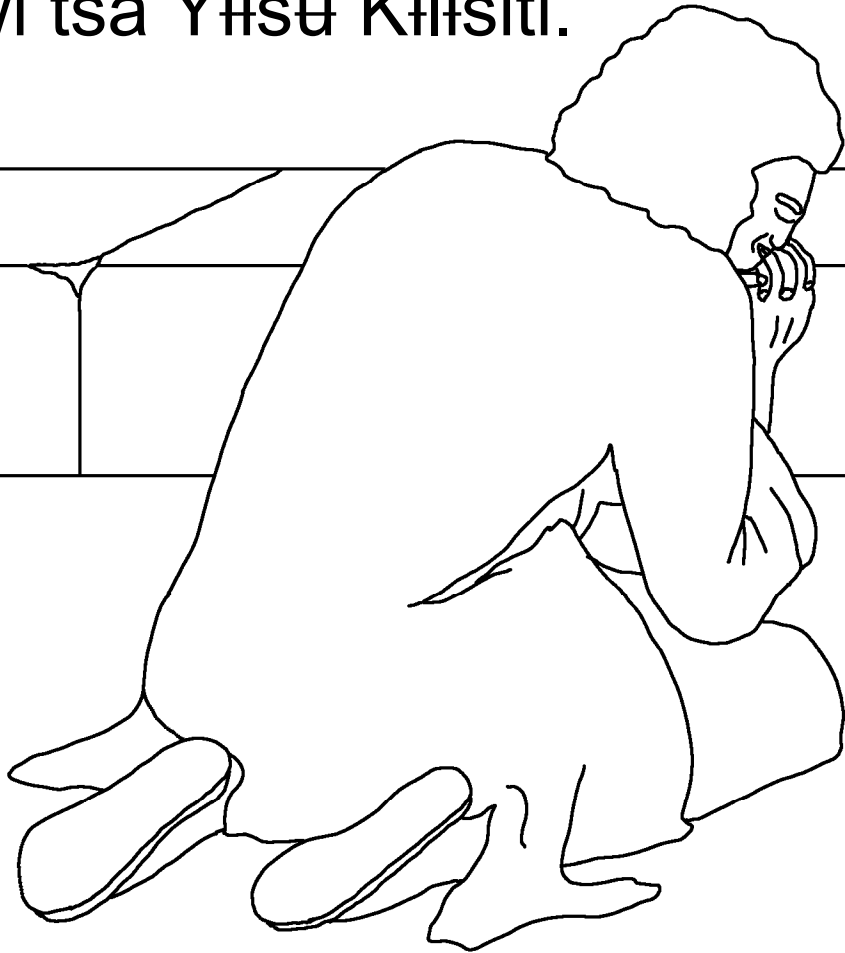

Baaho, uMero uMbalatse akannyitsila, ndikakivona
ikinyalwangula kya Ludeeva kiviikilwe kukyanya nuulya
uvakitaamyе.



Pwɛ, ndikarɛlika isipeliwa syoni isya kɛkyanya ni sya
mu kilɛnga ni sya kɛ vɛtsɛka ni sya mu nyanza
sikwimba siita, “ɛmwene ɛvi
ataamile pa kɛnyalwangɛla kya
Lɛdeeva nɛ Kakolo vanogelanie
ɛkwɛpilila ɛlɛginio nɛ wɛmikiwa
nɛ vɛdwadwa na maka gooni
sikutsooni na
sikutsooni.”

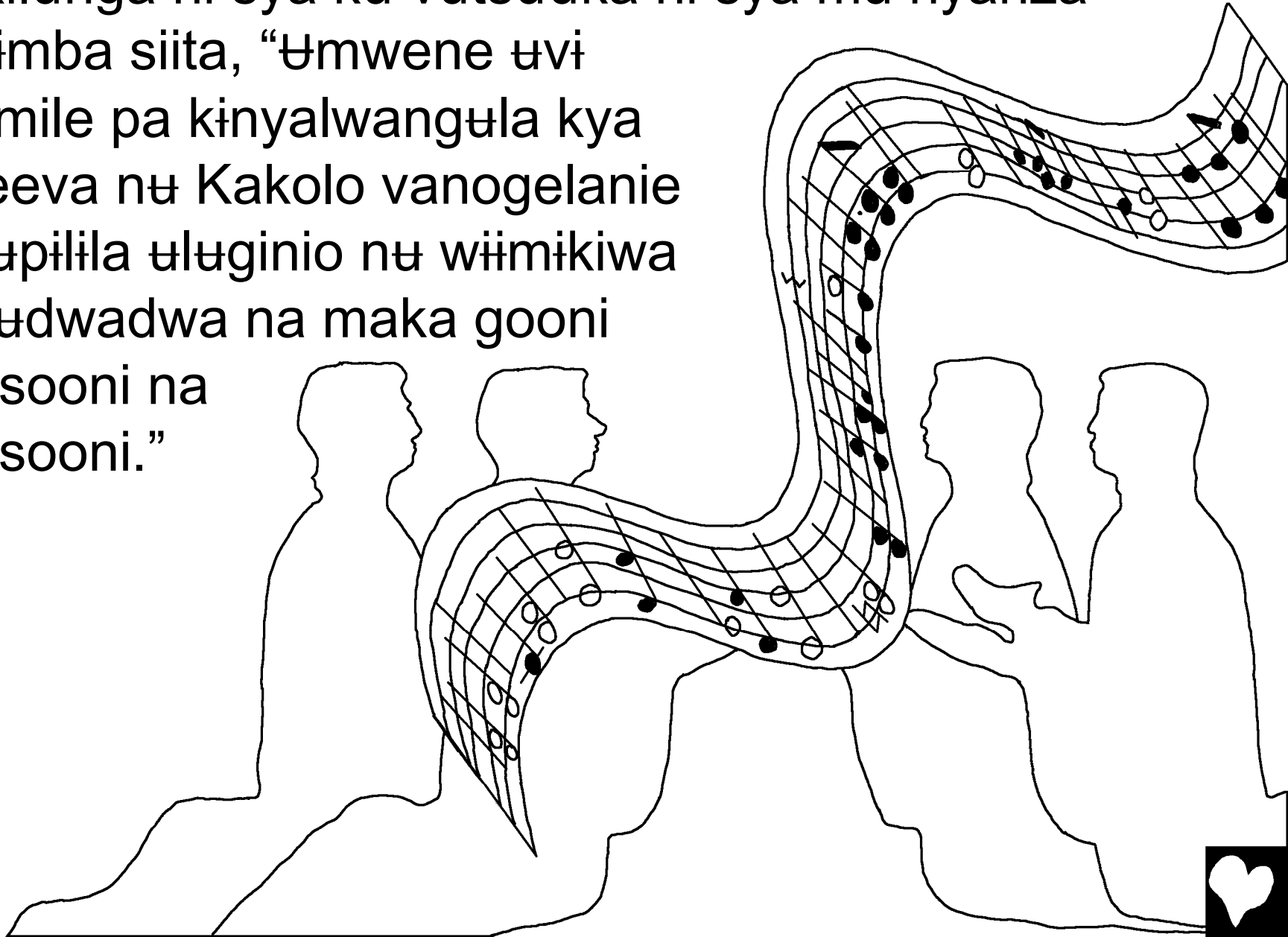

Ndikavuvona uvutsenge uvuvalatse, iYelusalemu
imya, vukwika ukhuma kukyanya kwa Ngulve.
Uvutsenge uwa waanotsiwe unonu ungata mminza
uvi avaanu vannotsiitse pa nsiki gwa vutegulanie. Pwv
ndikavulika ilimenyu ilivaha ukhuma pa kinyalwangula

kya Ludeeva
likata, “Lola!
Uvutaamo wa
Ngulve vuli
paninie na vaanu.
Itaamaga paninie
navo, viveetsaga
vaanu va mwene,
n mwene iveetsaga
Ngulve va veene.”

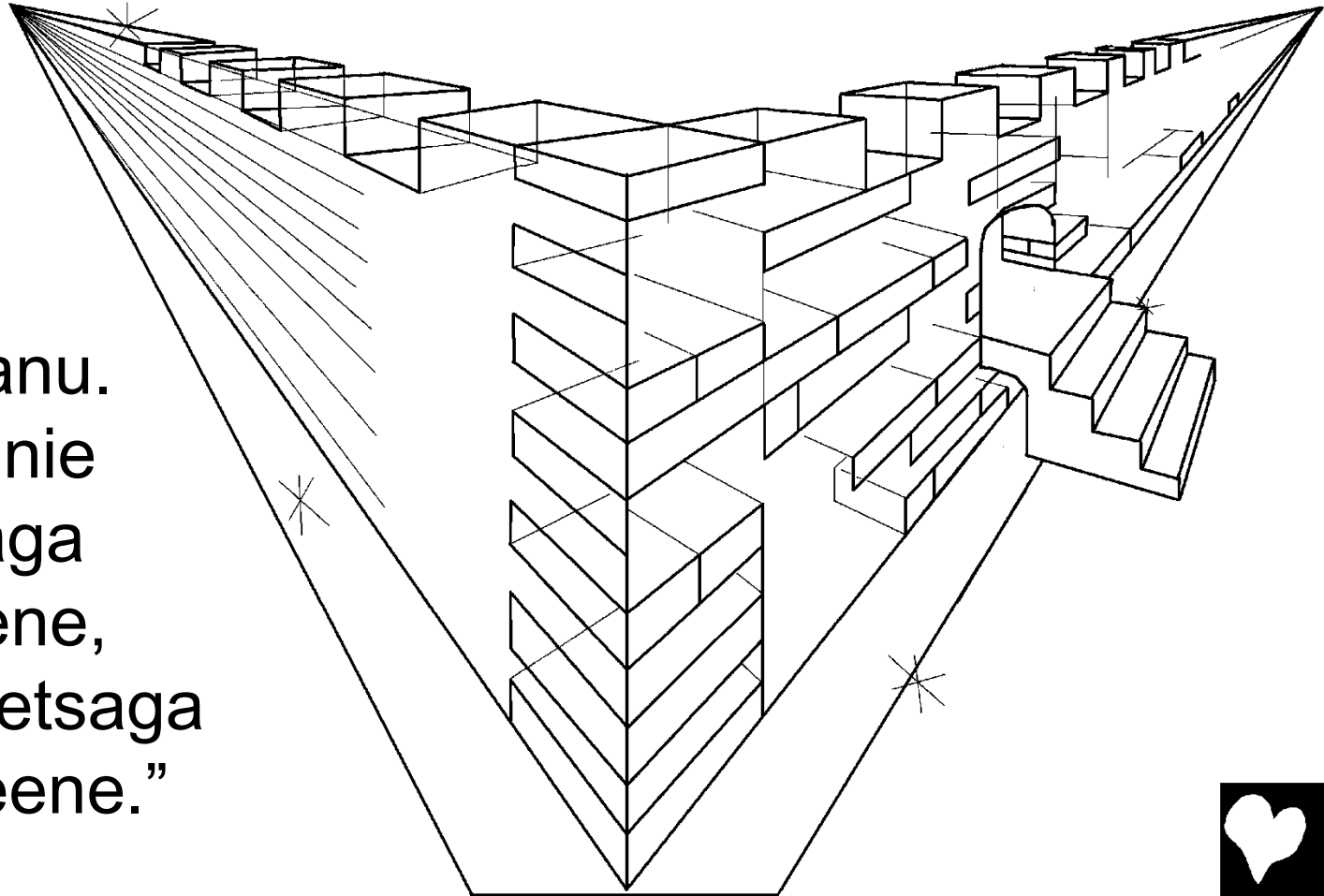

Pwɛ ɛnsung'wa akambonia ɛne ɛɛgasi ɛɛnya
magasi agikɛvapa avaanu ɛwɛɛmi ɛgwɛ gaale
mavalasu ɛngata kyovo. Ago gaahɛmaga pa
kinyalwangɛla kya Lɛdeeva kya Ngɛɛve nɛ Kakolo.



Ɔvɔtsenge ɔwa navumulikwa ni litsɔva pange nɔ
mwetsi, manya ɔwɔimikiwa wa Ngɔlɔve vukɔvumulikila
ikange inyaale jya weene vi Kakolo.

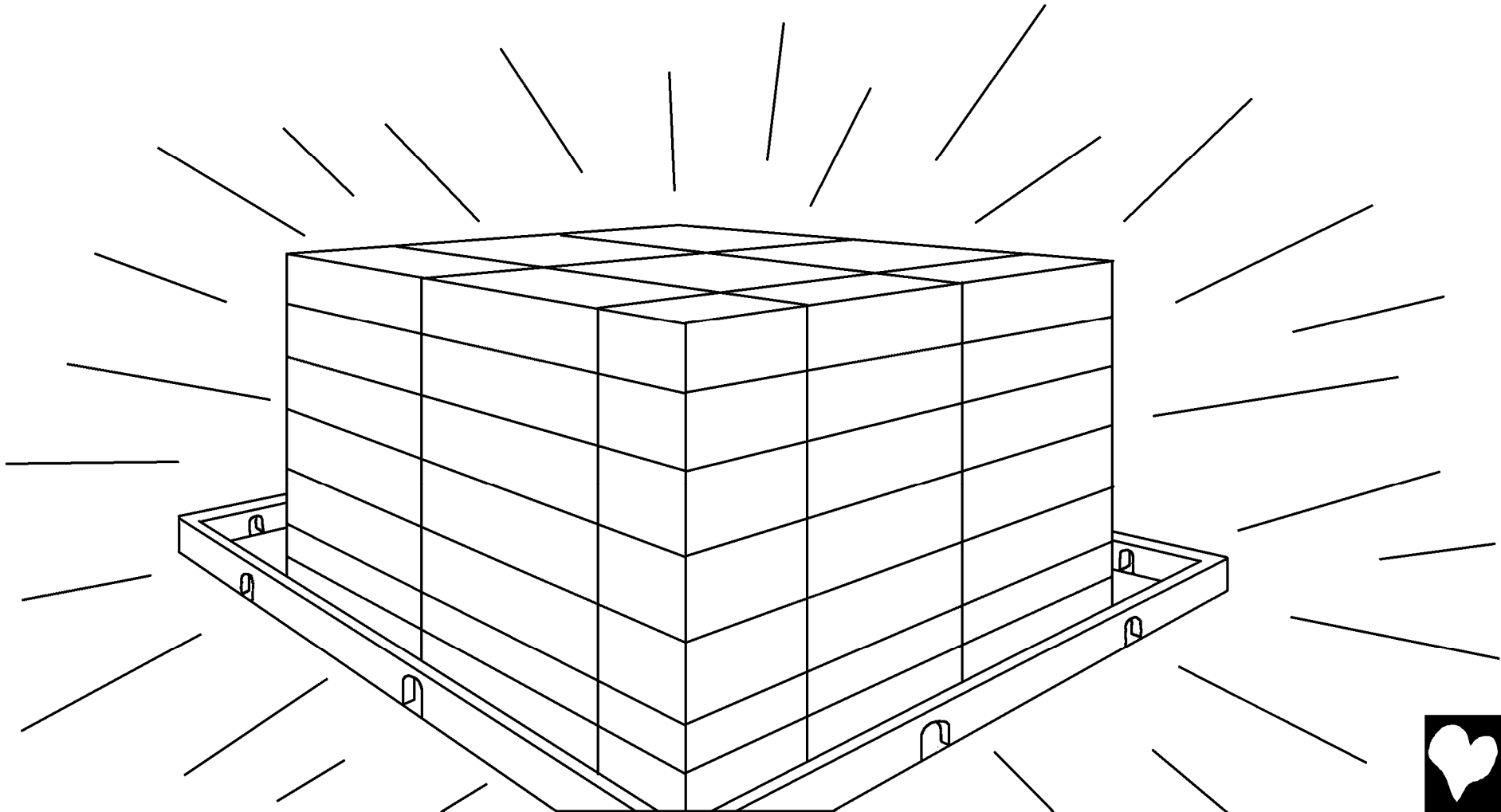

Lino nakilaavepwo
ikiveetsaga ikikolelanie
ikiliingila umwa, pange
umuunu uvaveetsaga
uvivomba itsili mwiko ne
kutsova ununuasi.

Apeene valiingila valya
veene unu amataawa
ga veene gaavigilwe mu
kitabu kya unumi kya
Kakolo.



Nakilaavemwo mu vutsenge ṭwa ikiinu ikiveetsaga
ikikootoliwe n̄ Ng̣ṭve. tkinyalwang̣la kya Ḷdeeva
kya Ng̣ṭve ni kya Kakolo kilaavemwo mu vutsenge
ṭwa. Avavombi va mwene valisajaga k̄ mwene.

Valalola k̄miiho k̄
mwene, ni litaawa
lya mwene lilavigwa
pa mb̄mila
tsa veene.



Pwɛ ndikavavona avaswe, avimikiwa na vibedwa,
vimile pavɛlongolo pa kinyalwangɛla kya Lɛdeeva.
Sikadindɛlwa isitabu ɛmwɛ tsivigilwe imbombo tsa
vaanu vooni. Ikange kikadindɛlwa ikitabu ikinge, ikitabu
ikyo kyale kya wɛɛmi. Pwɛ
ɛNgɛɛve akavahiga avaswe ɛkɛkongana
nɛ lɛgendo lwa veene, ndɛwɛ
lwavigilwe mu sitabu isyo.
ɛmuunu ɛvaveetsaga
ɛvi ilitaawa lya
mwene nalyavoneke
mu kitabu kya wɛɛmi,
akataagwa mu lisiva ilyo
iliviika ɛmwoto.

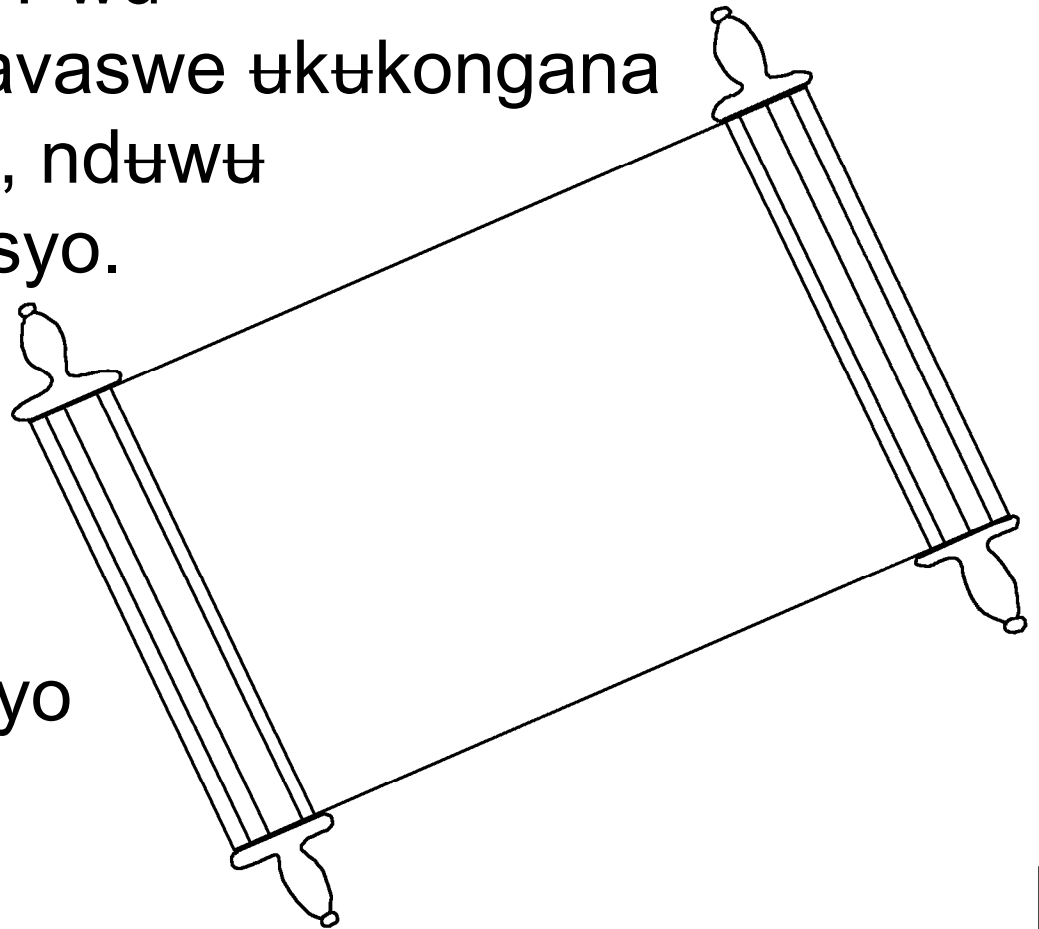

⊕Mepo ⊕Mbalatse n⊕ mwene ⊕vi itegulwa viita,
“Wiitsage!” Pw⊕ namwene ⊕vaveetsaga ⊕vi ipulika
amamenyu aga ateetsage, “Wiitsage!” Namwene ⊕vi ali
ni ky⊕milwa iitse, ⊕vi inogwa amagasi agik⊕vapa
avaanu ⊕w⊕mi, iitse ⊕pilile kitsila k⊕hombela.



Lola, ʘNgʘlʘve
aavaganile siitso
avaanu vooni va mu ilʘnga ʘmʘ.
ʘkʘkongana niilyo, aansuung'ile ʘMwana
va mwene ʘlʘdiiga, iitse, aswe pa
kʘvavoka avatulanongwa va mu kilʘnga
ʘmʘ, pakʘta ʘmuunu ʘvaveetsaga
ʘvi ikʘmwidika aleke ʘkʘjaga,
apeene akave ʘwʘʘmi
wa sikutsooni.

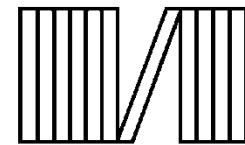

Valooma 3:23

Lola, avaanu vooni vagalwike, ɛɛgendo lwa veene naluvonia ɛwɛmikiwa wa Ngɛɛve.

Valooma 6:23

Lola, ɛmuunu ɛvaveetsaga ɛvi mbanda va vɛtulanongwa, ɛɛhombɔ lwa mwene wɛ vɛswe wa sikutsooni. Lino ɛNgɛɛve ikɛtɛpa ɛwɛɛmi wa sikutsooni,

Vaebulaniya 9:27

Ikange ɛwɛɛmi ɛwa nalwiva lɛhombɔ, apeene lwiva lwokelo kɛ nzila jya Mesiya ɛYɛsɛ, ɛNtwa viitu. Ikange ndɛwɛ avaanu vooni vavɛkiliilwe ɛkɛswa karamato vɛvɛle pɛ kɛkongage ɛkɛhigwa,



Vaefeso 2:8,9

Mwarokilwe kɛ lɛhɛngɛ lwa Ngulɛve ɛpɛwɛ mwamwidiike ɛYɛsɛ. ɛvɛpoki ɛwa navuhɛmana ni mbombo tsiinyo, aɛene kipeetsano vɛvɛle ɛkɛhɛma kwa Ngulɛve. Manya ɛvɛpoki ɛwa nalɛhombɔ lwa mbombo tsiinyo inonu itsɛ muvombile, ɛmuunu ɛvaveetsaga aleke ɛkwɛginia.

Valooma 10:9,10

Ikange lili piipi nɛvɛ, manya ɛngatsove kɛ ndomo gwako jyɛve ɛkɛta, “ɛYɛsɛ vi Ntwa,” nɛ kwidika mu numbula jyako ɛkɛta ɛNgulɛve aantsɛɛsiitse, ɛNgulɛve ikɛkɛpoka ɛve. Manya ɛmuunu ikwidika ni numbula jya mwene, pɛwɛ ivalilwa ɛkɛta in'golosu, ikange itsova nɛ ndomo gwa mwene jyɛmwene, pɛwɛ ipokwa.



Yohana 3:16,17 Lola, uthu ngulwe aavaganile siitso avaanu vooni va mu kilunga umu. Ukukongana niilyo, aansuung'ile uMwana va mwene uthu diiga, iitse, aswe pa kuvapoka avatulanongwa va mu kilunga umu, pakuta umuunu uvaveetsaga uvi ikumwidika aleke ukujaga, apeene akave umuuni wa sikutsooni. Uthu ngulwe naansuung'e uMwana va mwene mu kilunga pakuta avahige avaanu, apeene aansuung'ile pakuta avapoke.

1 Yohana 5:11-13 Uwooleletsi uwa wu uhu: Uthu ngulwe atupye umuuni wa sikutsooni. Umuni uwa tukuwupilila ukhuma ku Mwana va mwene. Umunu uvali nu vuhange nu Mwana va Ngulwe, ali nu wuni uwa. Lino, umunu untsila vuhange nu Mwana va Ngulwe, nali nawo umuni uwa. Ndikuvavigila amamenyu ago, unyie nyi mukulyidika ilitaawa Iya Mwana va Ngulwe, pakuta mulumanye ukuta muli nu wuni wa sikutsooni.



Yohana 14; 2 Vakolinto 5; Luvonekelo 4, 21, 22

Storyline by: Edward D. Hughes

Illustrated by: Lazarus
and Alastair Paterson

Adapted by: Sarah S.

Kinga NT (zga) © 2019, Wycliffe Bible Translators, Inc.
All rights reserved.

<https://live.bible.is/bible/ZGAWBT/MAT/1>

©2025 Bible for Children, Inc.

www.M1914.org

www.bibleforchildren.org

