

Yohana 14

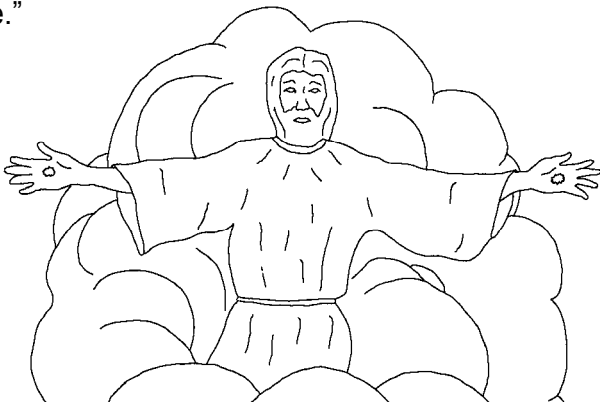

“Muleke ukusuvuala mu numbula tsiinyo, mukumwidika uNgulube, innyidikagi najyune. Uvutaamo vuvaha mu nyumba jya Daada. tkaale ileke ukava wu jiliwo, ndalino ndivanvulile, manya ndili mu nzila ukuluta kukuvanotsehetsa aponu apakava unyie.”



“Wu ndilutile nu kuvanotsehetsa, jundikilivuka ikange kukuvatoola unyie pakuta aponu urwu ndiiva, najyunyie ruw muveetsage paninie nuune.”

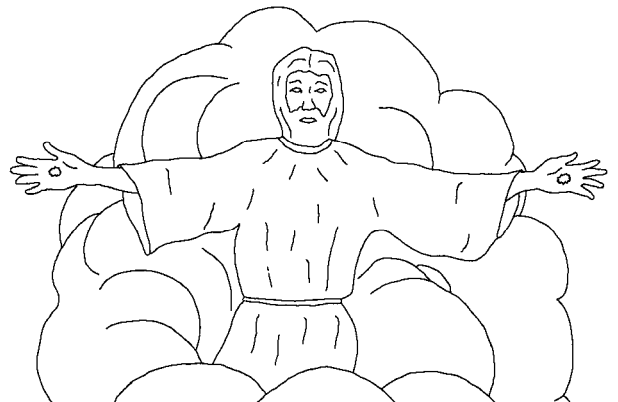

Þne neene Yohana, ndi mwidikin'jiinyo ikange neene ndili paninie nũnyie pa kulongwi jya kũnkonga uYĩsũ Kilisiti mu vukũvilwa na

mu Lũdeeva lwa mwene na mu lwijũmĩlitso.



3

Ndyakũngilwe mu kilũnga ikili pagati pa Nyanza ikitambũlwa Patimo pakũva ndyalũm bililaga ilimenyu lya Ngũlũve nũ kwoleletsa

ikulongwi tsa Yĩsũ Kilisiti.

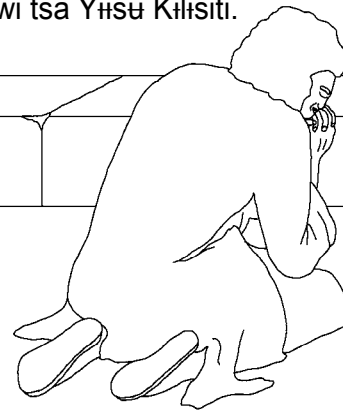

4

Baaho, uMepo uMbalatse akannyitsila, ndikakivona ikinyalwangũla kya Lũdeeva kiviĩkilwe kũkyanya nũulya uvakitaamye.

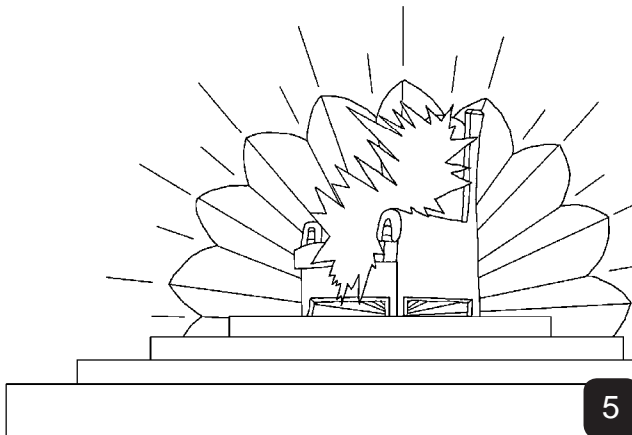

5

Pwũ, ndikapũlika isipeliwa syoni isya kũkyanya ni sya mu kilũnga ni sya kũ vutsũuka ni sya mu nyanza sikwimba siita, "Þmwene uvi ataamile pa kinyalwangũla kya Lũdeeva nũ Kakolo vanogelanie ukwũpilila ulũginio nũ wiimikiwa nũ vudwadwa na maka gooni sikutsooni na sikutsooni."

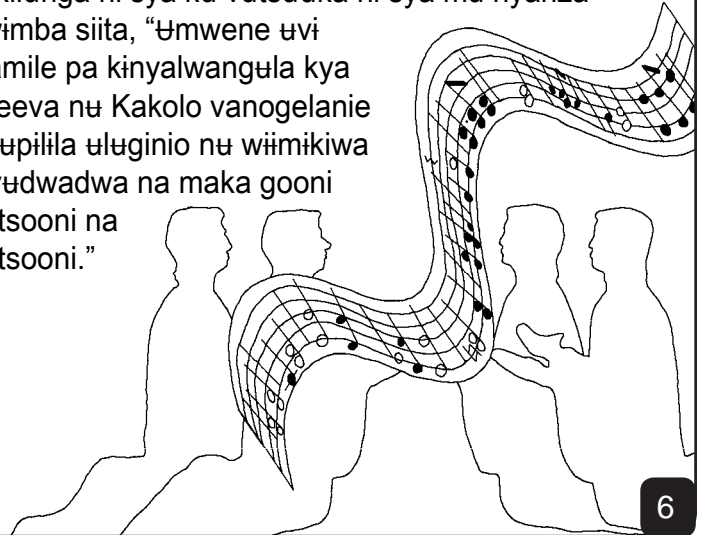

6

Ndikavũvona uvutsenge uvũvalatse, iYelusalemu iĩmya, vukwika ukũhũma kũkyanya kwa Ngũlũve. Þvutsenge uwa waanotsiwe vũnonu ungata mminza uvi avaanu vannotsiitse pa nsiki gwa vutegũlanie. Pwũ ndikapũlika ilimenyu ilivaha ukũhũma pa kinyalwangũla kya Lũdeeva likata, "Lola! Þvũtaamo wa Ngũlũve vũli paninie na vaanu. Itaamaga paninie navo, viveetsaga vaanu va mwene, nũ mwene iveetsaga Ngũlũve va veene."

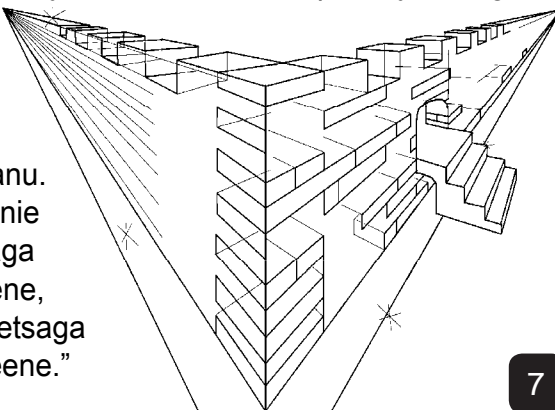

7

Pwũ unũung'wa akambonia þne ulũgasi ulũnya magasi agikũvapa avaanu uvũũmi ugũw gaale mavalasu ungata kyovo. Ago gaahũmaga pa kinyalwangũla kya Lũdeeva kya Ngũlũve nũ Kakolo.

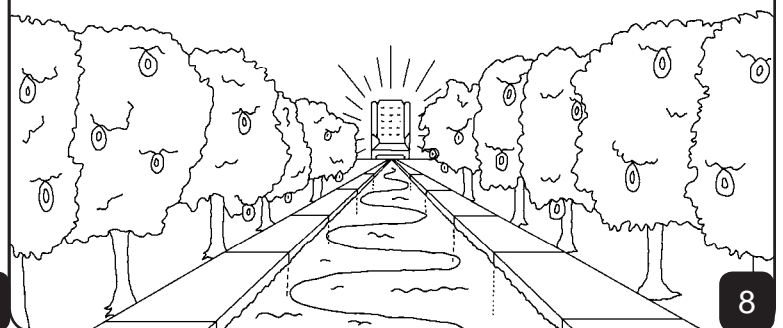

8

Uvutsenge uwa navumulikwa ni litsuva pange nu mwetsi, manya uwimikiwa wa Ngulave vukuvamulikila ikange inyaale jya weene vi Kakolo.

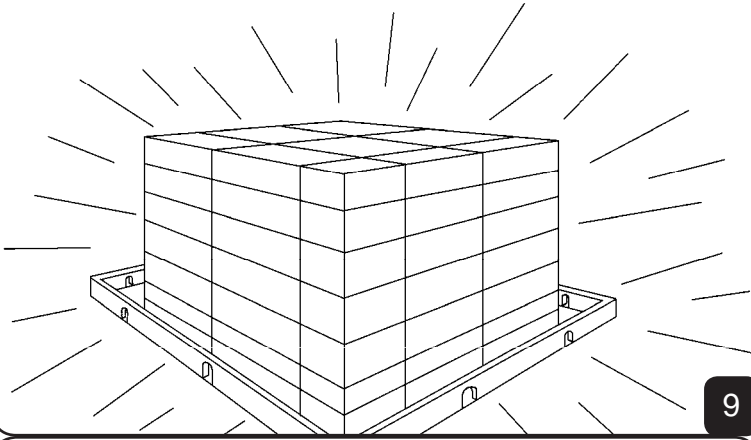

9

Lino nakilaavewo ikiveetsaga ikikolelanie ikilingila umwa, pange umuunu uvaveetsaga uvivomba itsili mwiko nu kutsova unuasi. Apeene valiingila valya veene uwu amataawa ga veene gaavigilwe mu kitabu kya wumi kya Kakolo.

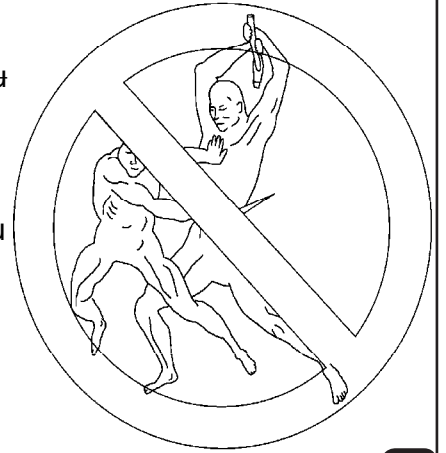

10

“Umwene alavapulusa inyihotsi tsa veene tsyoni. Uvuswe navulaavewo ikange, pange luvavo, pange kulila, pange lukuuto, manya itsa katale tsiluting’iinie!”



11

Nakilaavemwo mu vutsenge uwa ikiinu ikiveetsaga ikikootoliwe nu Ngulave. tkinyalwangula kya Ludeeva kya Ngulave ni kya Kakolo kilaavemwo mu vutsenge uwa. Avavombi va mwene valisajaga ku mwene. Valalola kumiiho ku mwene, ni litaawa lya mwene lilavigwa pa mbumila tsa veene.



12

Pwu ndikavavona avaswe, avimikiwa na vibedwa, vimile pavulongolo pa kinyalwangula kya Ludeeva. Sikadindulwa isitabu umwu tsivigilwe imbombo tsa vaanu vooni. Ikange kikadindulwa ikitabu ikinge, ikitabu ikyo kyale kya wumi. Pwu uNgulave akavahiga avaswe ukukongana nu lugendo lwa veene, nduwu lwavigilwe mu sitabu isyo. Umuunu uvaveetsaga uvi ilitaawa lya mwene nalyavoneke mu kitabu kya wumi, akataagwa mu lisiva ilyo iliviika umwoto.

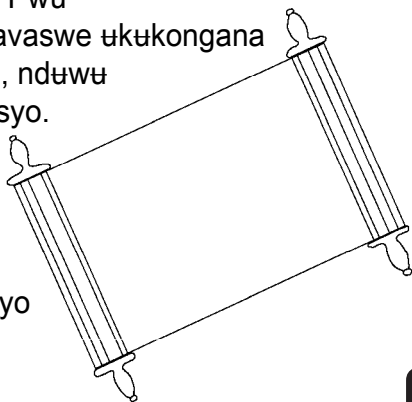

13

UMepo uMbalatse nu mwene uvi itegulwa viita, “Wiitsage!” Pwu namwene uvaveetsaga uvi ipulika amamenyu aga ateetsage, “Wiitsage!” Namwene uvi ali ni kyumilwa iitse, uvi inogwa amagasi agikuvapa avaanu uwumi, iitse upilile kitsila kuhombela.

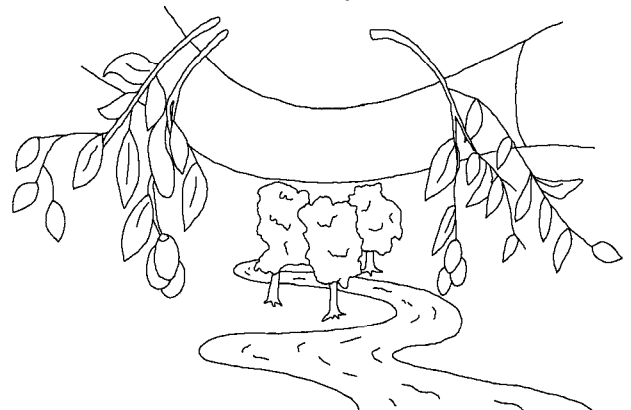

14

Lola, uNguluve aavaganile siitso avaanu vooni va mu kilunga umu. Ukukongana niilyo, aansuung'ile uMwana va mwene uludiiga, iitse, aswe pa kuvapoka avatulanongwa va mu kilunga umu, pakuta umuunu uvaveetsaga uvi ikumwidika aleke ukujaga, apeene akave wuumi wa sikutsooni.

Valooma 3:23

Lola, avaanu vooni vagalwike, ulugendo lwa veene naluvonia uwimikiwa wa Nguluve.

Valooma 6:23

Lola, umuunu uvaveetsaga uvi mbanda va vutulanongwa, uluhombo lwa mwene wu vuswe wa sikutsooni. Lino uNguluve ikutupa wuumi wa sikutsooni,

Vaebulaniya 9:27

Ikange wuumi uwa nalwiva luhombo, apeene lwiva lwokelo ku nzila jya Mesiya uYisu, uNtwa viitu. Ikange nduwu avaanu vooni vavikiliilwe ukuswa kapamato vuvule puw kukongage ukuhigwa,

Vaefeso 2:8,9

Mwapokilwe ku luhungu lwa Nguluve puw mwamwidiike uYisu. Uvupoki uwa navuhumana ni mbombo tsiinyo, apeene kipeetsano vuvule ukuhuma kwa Nguluve. Manya uvupoki uwa naluhombo lwa mbombo tsiinyo inonu itsu muvombile, umuunu uvaveetsaga aleke ukwiginia.

Valooma 10:9,10

Ikange lili piipi nuuve, manya ungatsove ku ndomo gwako juuve ukuta, "uYisu vi Ntwa," nu kwidika mu numbula jyako ukuta uNguluve aantsuusiitse, uNguluve ikukupoka uve. Manya umuunu ikwidika ni numbula jya mwene, puw ivalilwa ukuta in'golosu, ikange itsova nu ndomo gwa mwene jyumwene, puw ipokwa.

Yohana 3:16,17 Lola, uNguluve aavaganile siitso avaanu vooni va mu kilunga umu. Ukukongana niilyo, aansuung'ile uMwana va mwene uludiiga, iitse, aswe pa kuvapoka avatulanongwa va mu kilunga umu, pakuta umuunu uvaveetsaga uvi ikumwidika aleke ukujaga, apeene akave wuumi wa sikutsooni. uNguluve naansuung'e uMwana va mwene mu kilunga pakuta avahige avaanu, apeene aansuung'ile pakuta avapoke.

1 Yohana 5:11-13 Uwooleletsi uwa wu uvu: uNguluve atupye wuumi wa sikutsooni. Wuumi uwa tukuwupilila ukuhuma ku Mwana va mwene. Umuunu uvali nu vuhange nu Mwana va Nguluve, ali nu wuumi uwa. Lino, umuunu untsila vuhange nu Mwana va Nguluve, nali nawo wuumi uwa. Ndikuvavigila amamenyu ago, unyie nyi mukalyidika ilitaawa lya Mwana va Nguluve, pakuta mulumanye ukuta muli nu wuumi wa sikutsooni.

Yohana 14; 2 Vakolinto 5; Lavonekelo 4, 21, 22

Storyline by: Edward D. Hughes

Illustrated by: Lazarus and Alastair Paterson

Adapted by: Sarah S.

Kinga NT (zga) © 2019, Wycliffe Bible Translators, Inc. All rights reserved.

<https://live.bible.is/bible/ZGAWBT/MAT/1>