

www.BibleForChildren.org



Yowana 14



Yeesu ^naagenderera okubheeyigisha ^naaikaga ati,
“Mwasiga okutitibhara mu-mitima gyemwe,
omwikirisha Nyamuwanga, munyiikirishe anye noone.
Ewa Raata bhurimo bhwikaro bhwafu. Ikabheeye itari
kutyo, nikabhabhwiriye.”

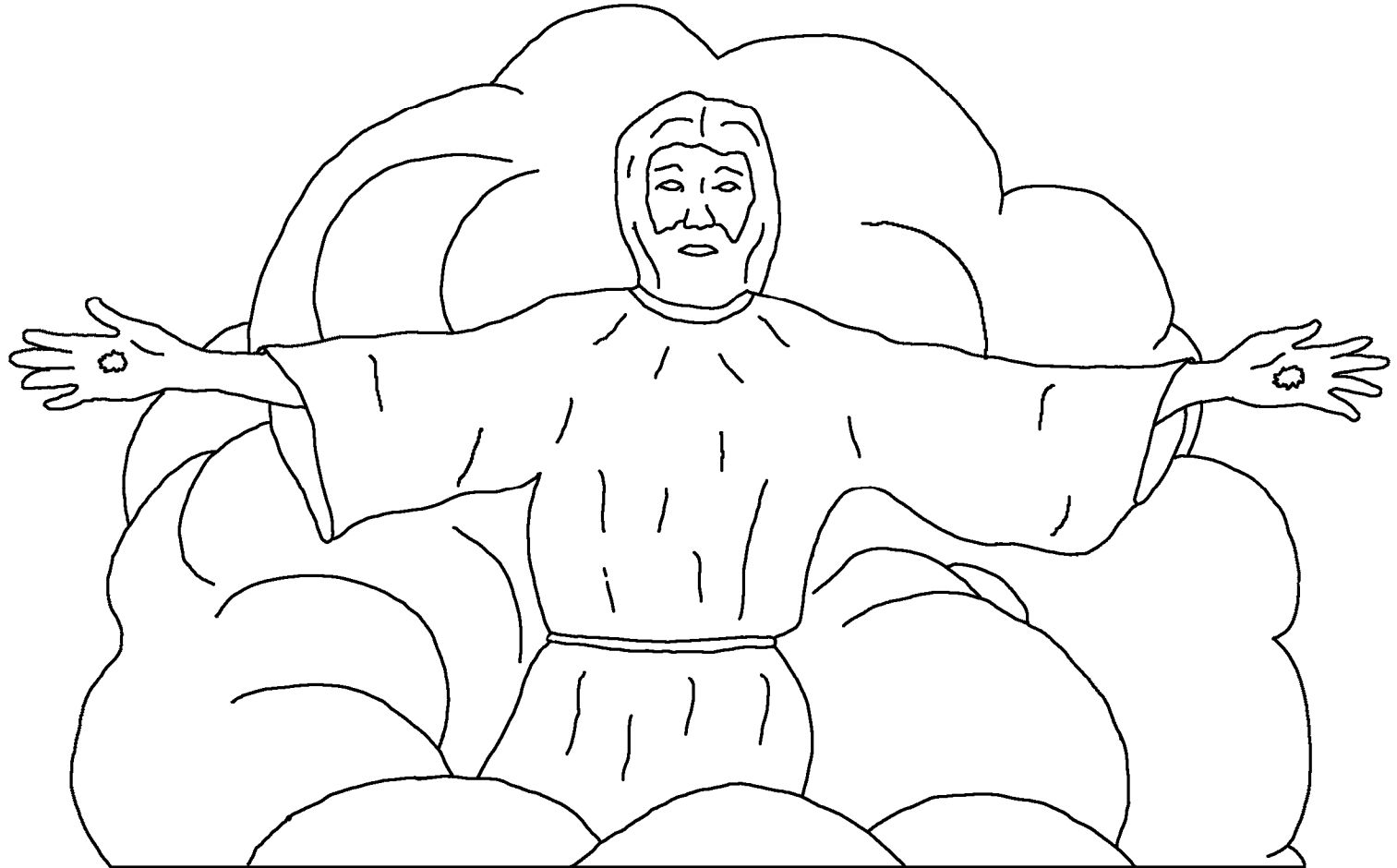

“Anye enigenda okubharoosisha owa okwikara.
Mmbe nikagenda okubharoosisha owa okwikara,
nirisubha nibhagege, insonga anu niribha,
emwe mwone mubhe ayoayo.”



Ni anye Yowana Omukiriisitu weejaanyu. Unu eniyimbana na emwe okusimbiira giinyanko ku-nsonga ya Yeesu na obhukama

bhwaye. :Naariga nibhoyerwe kw-isinga



rinu eritogwa Paatimo.



:Naabhoyerwe eyo kwa okubha :naaraashaga
Riing'ana rya Nyamuwanga na okubhwira
abhaanu amang'ana ganu Yeesu

:aakoraga.

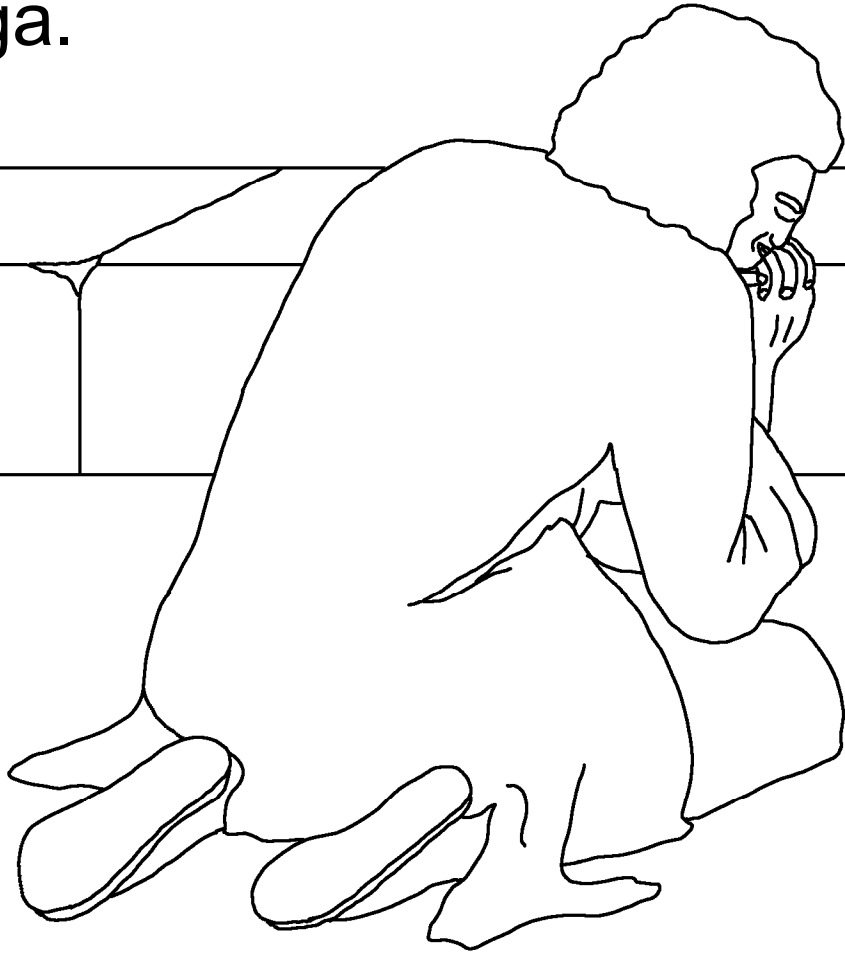

Nintaka era Mwoyo Omutaakatiifu ^nnaawunga,
nindora ekitebhe kya ekikama mu-rwire,
kiikaaywe-ko na omuunu.



Niwe nuungwa ebhibhumbwa bhya mu-rwire bhyone kutyo, na ebhya ku-kyaro, bhinu bhiri nyombe, na bhinu bhiri mu-nyanja mbimbira amwi, mbyaikaga ati, “Ginkuma, ekibharo, obhugungyo na obhuturo bhuri ku-unu eekaaye ku-kitebhe kya ekikama, na ling’ondi ya Nyamuwanga, kajaanende!”

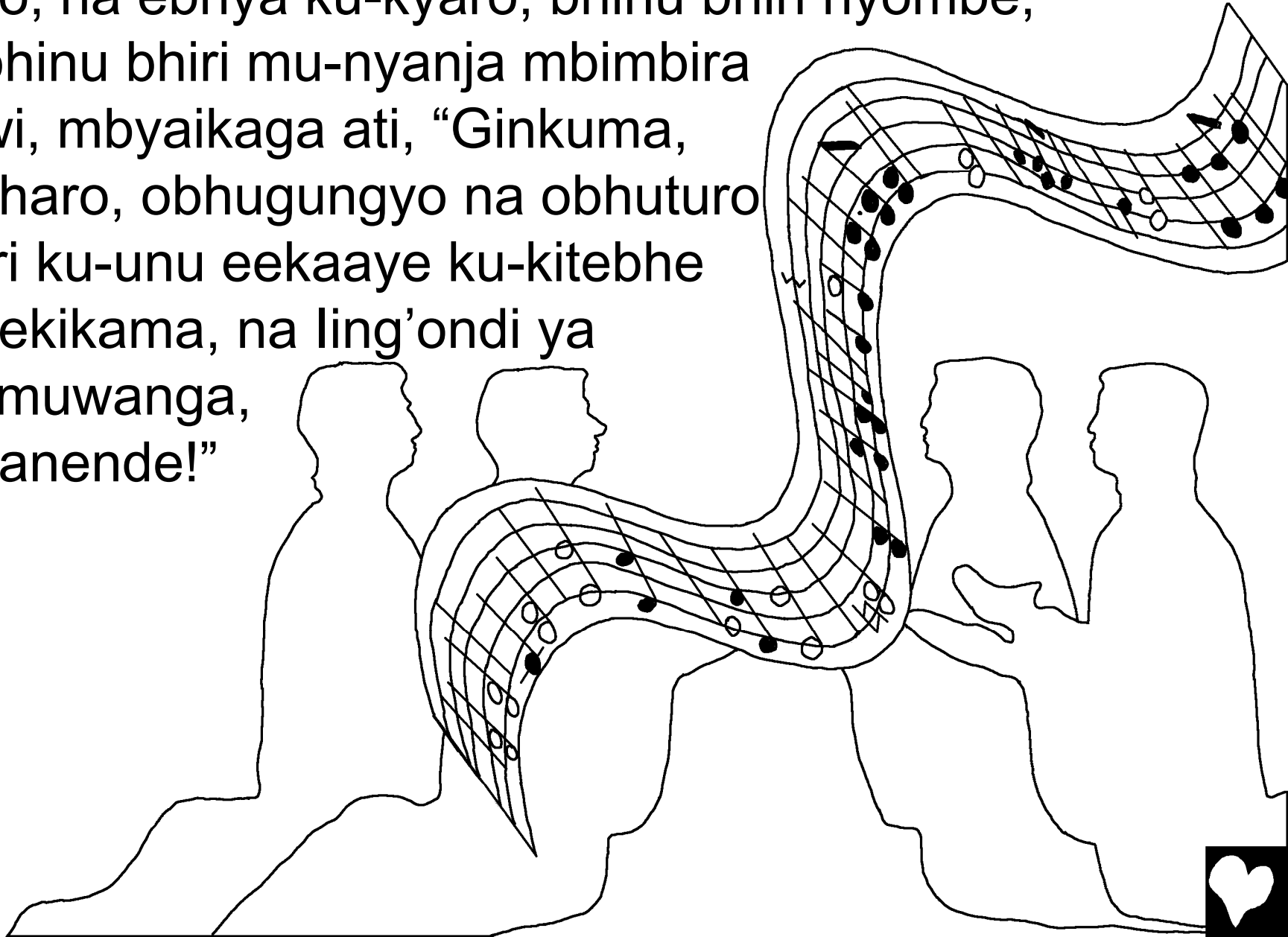

Nindora omusi omutaakatiifu, Yerusareemu omuyaaya, ngwika okusooka mu-rwire ku-Nyamuwanga. Omusi guyo :gwariga guroosiibhwe rwa omwenga unu aamarire okwituura-wo okugabhurwa. Nuungwa esi enene ndisooka ku-kitebhe kya ekikama, ndyaika ati,

“Ringira woori!

Obhwikaro bhwa Nyamuwanga bhuri amwi na abhaanu. Ariikara amwi na abhaanu, na abhaanu bharibha bhaanu bhaaye, omwene woone aribha Nyamuwanga weebhwe.”

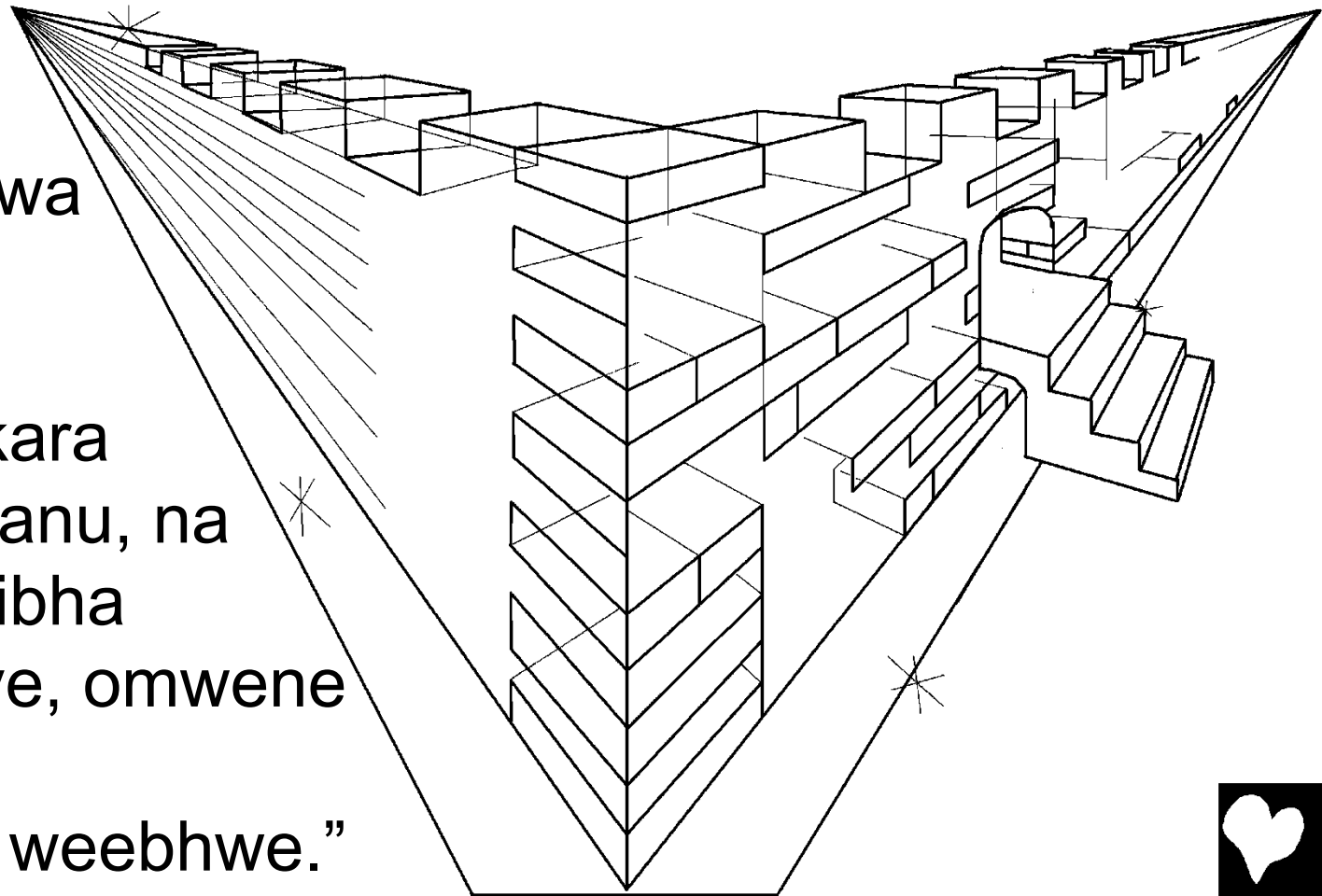

Kimwi maraayika ^naanyereesha oruuji rwa amanji ga obhurame. Oruuji ruyo :rwariga ndung'arabhya rwa riitore, ndusookaga ku-kitebhe kya ekikama ekya Nyamuwanga, na ling'ondi waaye.



Omusi guyo gutakukena esuubha amwi ati okwesi,
kwa okubha obhugungyo bhwa Nyamuwanga
obhugumirikira, na ling'ondi ya Nyamuwanga niwe
intara yaagwo.

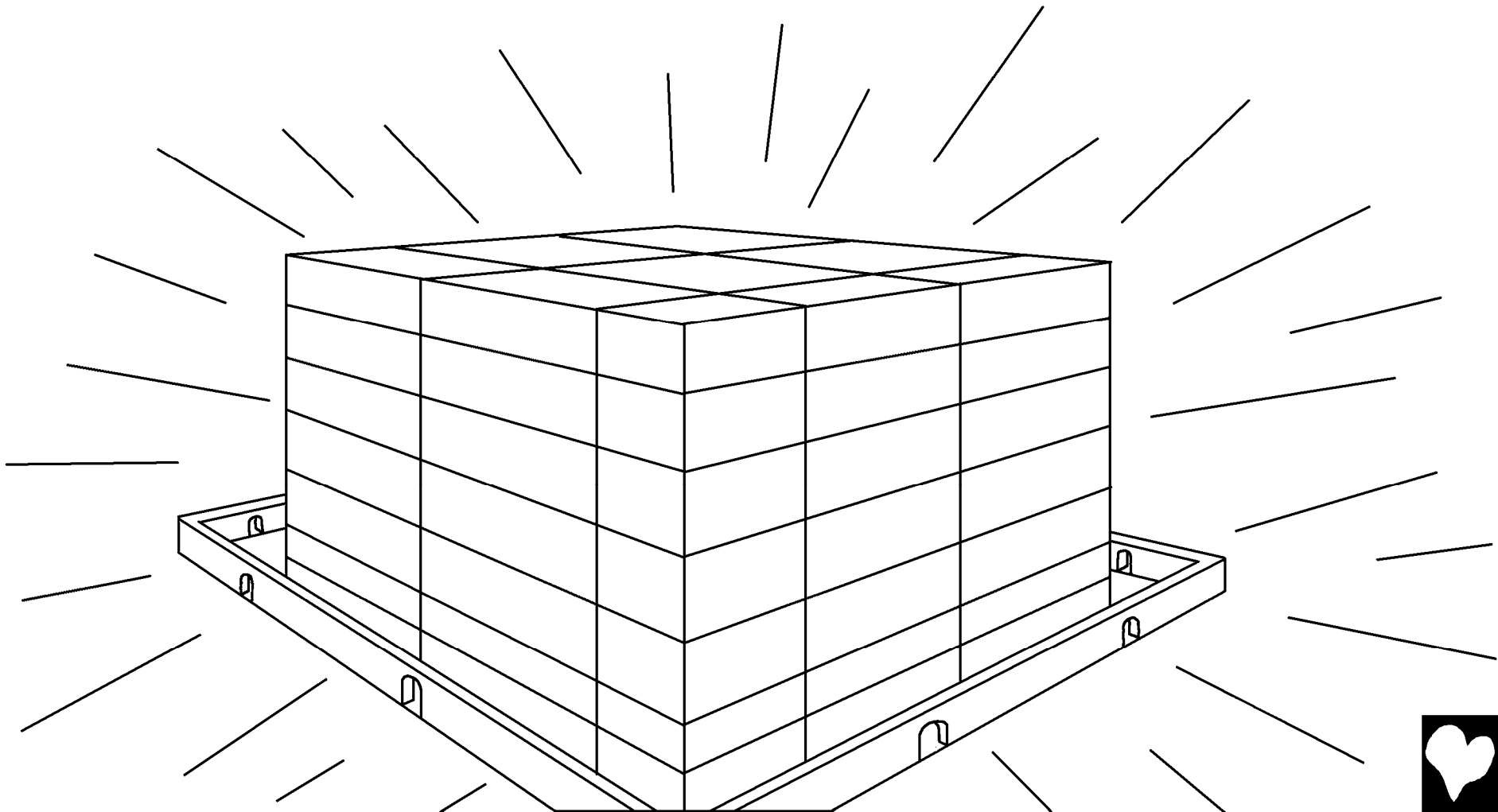

Nawe kitaribha-wo kiinu kijabhi, omubheeyi, amwi ati mukosi wa amabhiibhi woonewoone, unu ariingira mu-musi guyo. Tari bhanu bhariingira mu-musi guyo ni bhanu amasiina geebhwe gakaamirwe mu-kitabho kya obhurame ekya ling'ondi ya Nyamuwanga.



“Aryeya amasiga geebhwe goone kutyo. Mu-kabhaga kayo abhaanu bhatarifwa kweki, bhataririra bhuunyarufu, amwi ati okurira okundi, kweki bhataribha na bhwashe, kwa okubha amang’ana ga okwamba gaamarire okutura.”



Omusi guyo gutaribha na kiinu kyonekyone kinu
kiyimirwe na Nyamuwanga. Ekitebhe kya ekikama kya
Nyamuwanga na ling'ondi waaye, kiribha mu-musi
guyo, na abhajuuma bhaaye bharimuramy.

Na abhajuuma bha
Nyamuwanga bhayo,
bharimurora obhusu
bhwaye. Na riisiina
ryaye ririkaamwa
ku-bhisuusu
bhyebhwe.



Nindora abhafuuye bhoone kutyo, bhanu :bhaariga bhari na ekibharo na bhanu :bhaariga bhatari na ekibharo bhayambaaye imbere wa ekitebhe ekya ekikama kiyo. Niwe ebhitabho bhinu :bhyariga bhikaamirwe-mo ebhikorwa bhya abhaanu bhoone kutyo mbifumburwa.

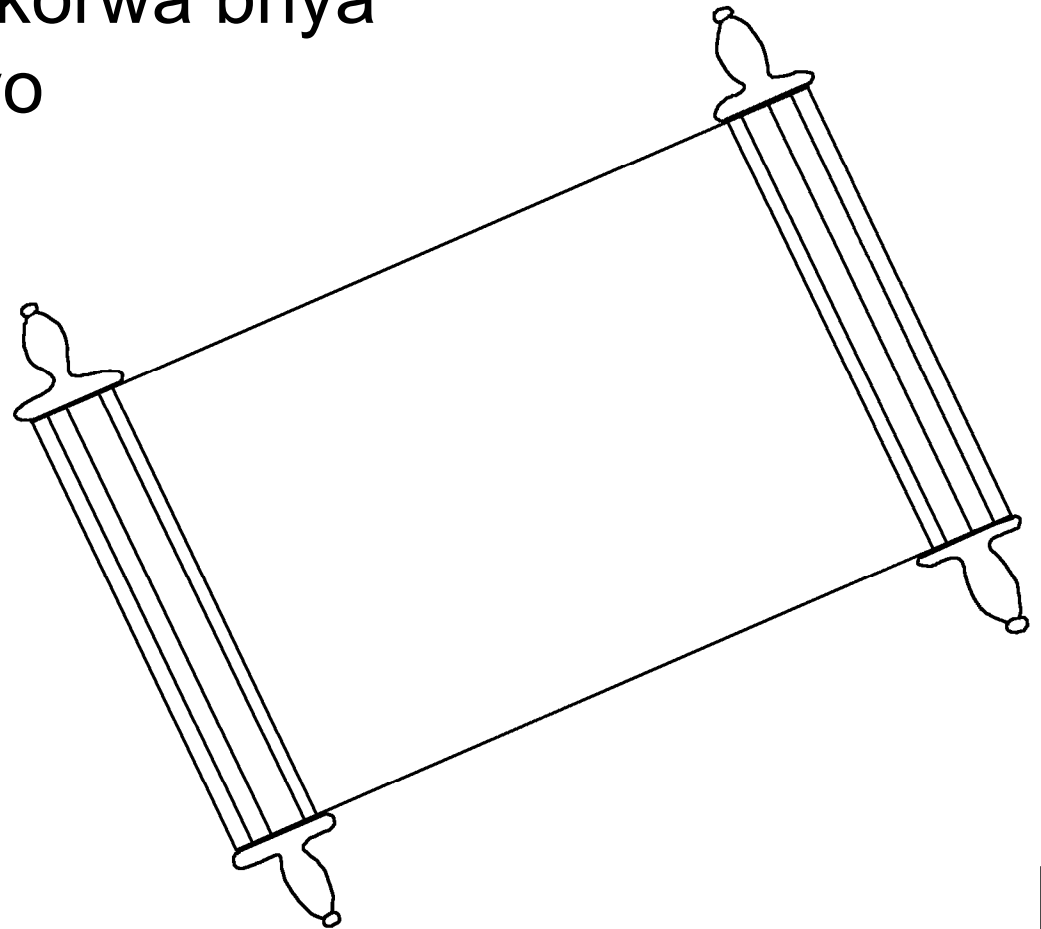

Ekitabho kya obhurame kyone nkifumburwa.
Abhafuuye bhoone kutyo mbaramurirwa okuriing'aana
na ebhikorwa bhyebhwe kutyo bhikaamirwe
mu-bhitabho bhiyo. Na omuunu woonewoone unu
riisiina ryaye ritakaamirwe mu-kitabho kya
obhurame, :eeserwe mw-ibheri muyo.

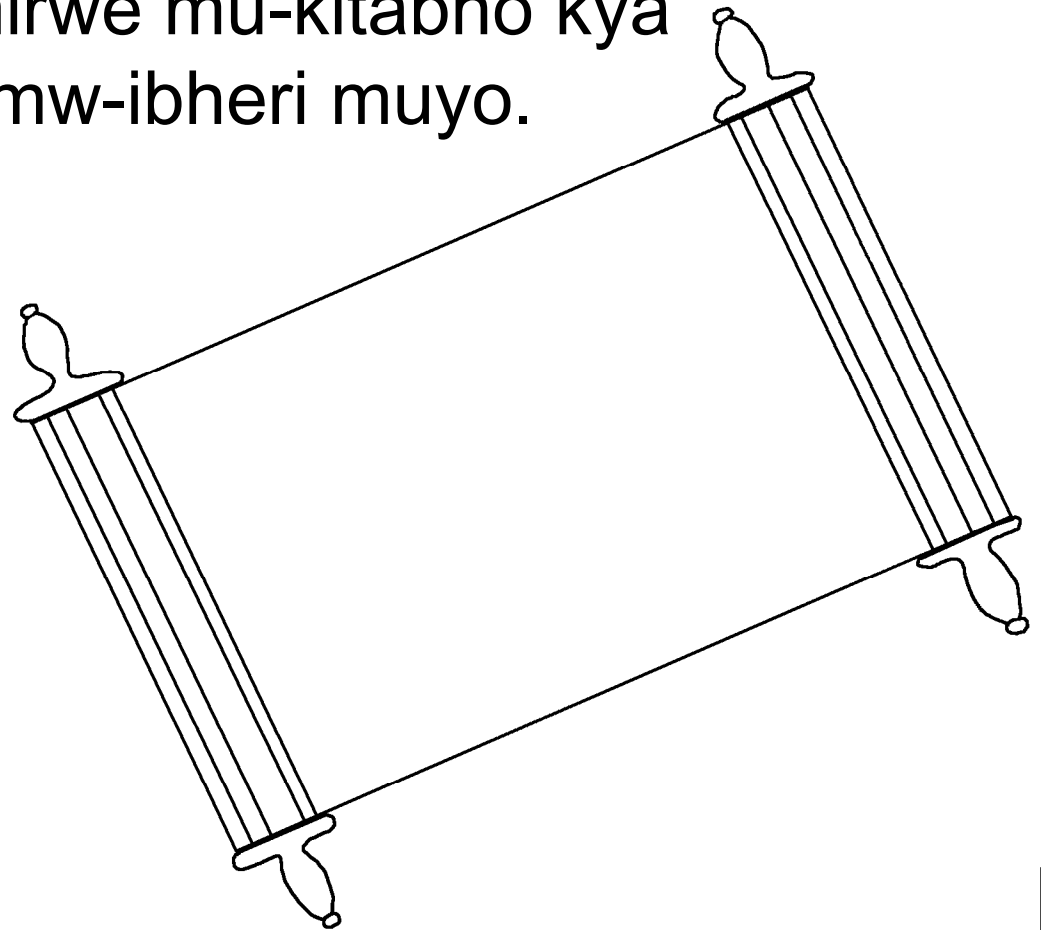

Mwoyo Omutaakatiifu wa Nyamuwanga na omwenga wa Yeesu abhaaika ati, “Nuuje!” Na abhaanu bhoone kutyo bhanu abhoongwa amang’ana gayo bhaaike ati, “Nuuje!” Woonewoone unu ari na obhwiro bhwa amanji aaje, na unu kaageenda, aaje era agege amanji ga

obhurame
bhusa.

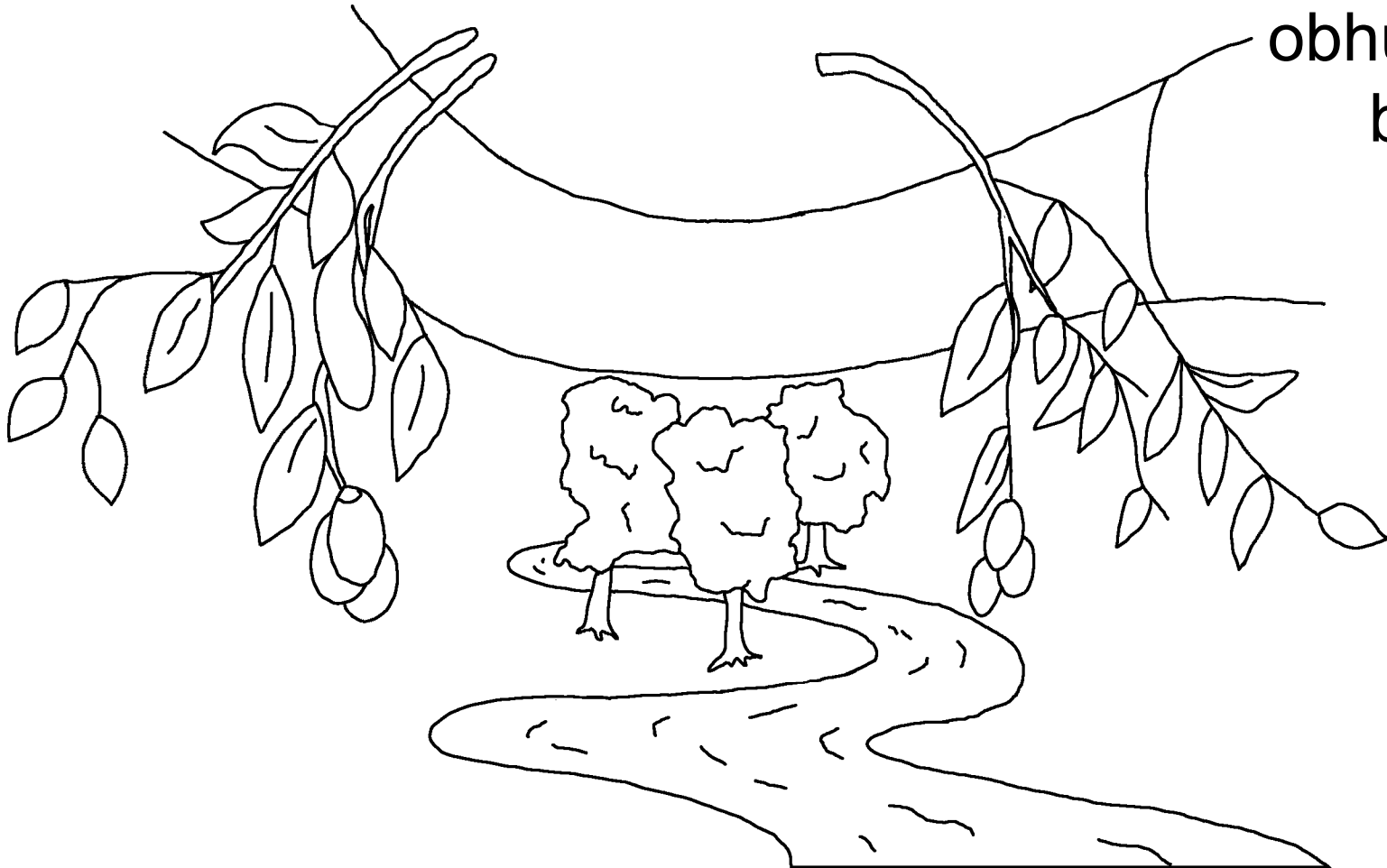

Nyamuwanga
:eendere muno abhaanu bhoone kutyo
abha mu-kyaro. Obhwendi bhuyo
mbukora ^naatuma omwana waaye
omumwemwe, insonga omuunu
woonewoone unu kaamwikirisha
asige okubhura, tari abhe na
obhurame bhunu
bhutakuweera.



Abharuumi 3:23

kwa okubha abhaanu bhoone kutyo bhakorere ebhikayo,
ebhikorwa bhyebhwe bhitakweresha obhugungyo
bhwa Nyamuwanga.

Abharuumi 6:23

Indiyo ya obhukosi bhwa ebhikayo ni rufu, tari
ekiyaanwa kya Nyamuwanga okuturira ku-Kiriisitu Yeesu,
Raatabhugenyi weeswe, ni bhurame bhunu bhutakuweera.

Abhaebhuraaniya 9:27

Rwa kutyo abhaanu bhoone kutyo bhatuuriywe-wo
okufwa rumwi era, na bhakamara okufwa mbaramurirwa
na Nyamuwanga.



Abhaefeso 2:8,9

Ni nema ya Nyamuwanga niyo ibheerusiishe okuturira ku-bhwikirisha bhwemwe, itari ati Omwerusibhwa okuturira ku-bhikorwa bhyemwe ebhijomu. Gunu ni musanga okusooka ku-Nyamuwanga omwene. Obhwerushwa bhutari ku-bhikorwa bhyemwe, insonga muunu woonewoone aasiga okwikumangya.

Abharuumi 10:9,10

Enaaika kutyo kwa okubha ukeekirisha Yeesu na akanwa kaawo ati, “Ni Raatabhugenyi” na ukeekirisha mu-mutima gwawo ati Nyamuwanga :aamusuurire okusooka mu-bhafuuye, oweerusibhwa. Omuunu akeekirisha Yeesu Kiriisitu okusookerera mu-mutima gwaye, kaabharwa ati ni murengeresi mu-meeso ga Nyamuwanga. Na okuturira ku-munwa, omuunu akeekirisha keerusibhwa.



Yowana 3:16,17

Nyamuwanga :eendere muno abhaanu bhoone kutyo abha mu-kyaro. Obhwendi bhuyo mbukora ^naatuma omwana waaye omumwemwe, insonga omuunu woonewoone unu kaamwikirisha asige okubhura, tari abhe na obhurame bhunu bhutakuweera. Nyamuwanga :ataatumire Omwana waaye mu-kyaro, ati aramurire abhaanu, tari abhaanu bheerusibhwe okuturira ku-mwene.



1 Yowana 5:11-13

Gayo nigo Nyamuwanga kaakibhwira ati, akiyaaye obhurame bhunu bhutakuweera. Na obhurame bhuyo kibhunyoorere okuturira ku-kwikirisha Omwana waaye.

Woonewoone unu ari na obhumwi na Omwana wa Nyamuwanga, ari na obhurame bhuyo. Nawe unu atari na obhumwi na Omwana wa Nyamuwanga, obhurame bhuyo atari nabhwo. Enibhakaamira amang'ana gayo, emwe bhanu omwikirisha riisiina rya Omwana wa Nyamuwanga, insonga mumenye ati muri na obhurame bhunu bhutakuweera.



Yowana 14; 2 Abhakotinto 5;
Obhusomboorerwa 4, 21, 22

Storyline by: Edward D. Hughes

Illustrated by: Lazarus
and Alastair Paterson

Adapted by: Sarah S.

Kwaya NT (kya) © 2023, Wycliffe Bible Translators, Inc.
All rights reserved

<https://www.bible.com/bible/3681/MAT.1.KYA>

©2026 Bible for Children, Inc.

www.M1914.org

www.bibleforchildren.org

