

Bibel fa Kjinja  
brinjt junt

Samuel, Een  
Jung dee Gott  
deend



Jeschräwen von: Edward Hughes  
Jemolt von: Janie Forest; Alastair Paterson  
Toom Pauss jestalt von: Lyn Doerksen  
Äwasat von: Ed Zacharias  
Hääjestalt von: Bible for Children  
[www.M1914.org](http://www.M1914.org)

BFC  
PO Box 3  
Winnipeg, MB R3C 2G1  
Canada

©2022 Bible for Children, Inc.

Jesazlich: Du doascht dise Jeschicht oppnämen ooda drekjen,  
soo lang aus du dee nich vekjafst.



De Fru, Hana, un äa Maun, Elkana wieren goode Menschen. See jleewden aun Gott un wieren äare Nobasch goot. Oba Hana fäld daut, daut see kjeen Bäbe haud. See luad, un see bäd un hopt, un luad noch mea. Doa wieren kjeene Kjinja.

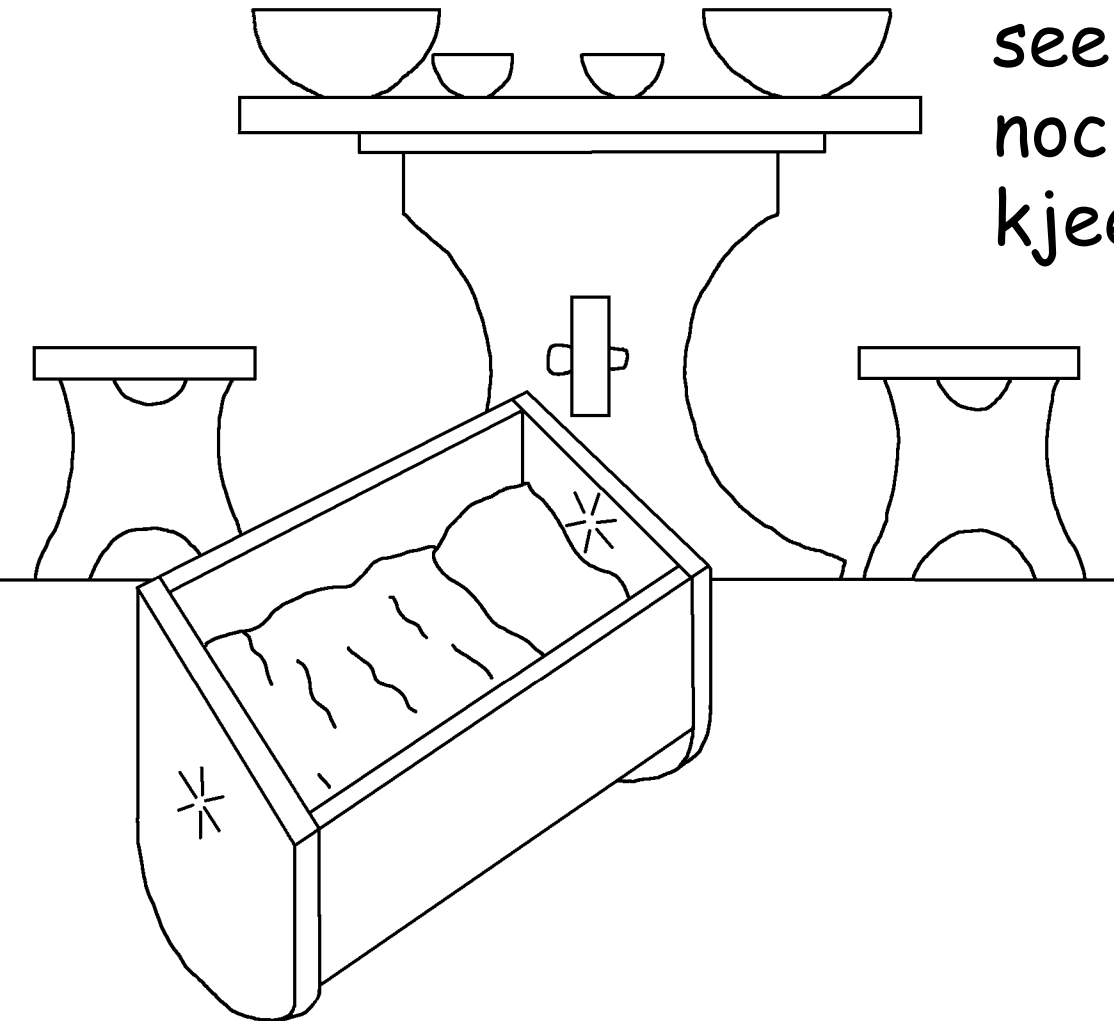



Jieda Joa jinkj Hana  
nom Vesaumlungs-zelt  
toom aunbäden. Eenmol  
vespruak see Gott, daut  
wan see kunn een Bäbe  
haben wudd see am loten  
opp emma Gott deenen.



De oola Priesta Eli  
sach Hana bäden.  
Hee docht see wia  
besopen wiels äare  
Leppen rieeden,  
oba see säd nuscht.  
Eli schull Hana.





Oba Hana säd Eli daut see  
fa een Sän jebät haud un  
waut see vesproaken haud.  
Dan säd Eli, "Go en Fräd.  
Mucht Israel äa Gott die  
daut jäwen om waut du  
jebät hast." Nu haud  
Hana Hopninj.



Nu kunn Hana sikj freien; un met de Tiet hauden  
see eenen Sän. See jeef am dän Nomen Samuel,  
wiels, soo säd see, ekj hab däm Harn doano  
jefroacht. Wudd Hana emdenkj hoolen  
waut see Gott vesproaken haud?

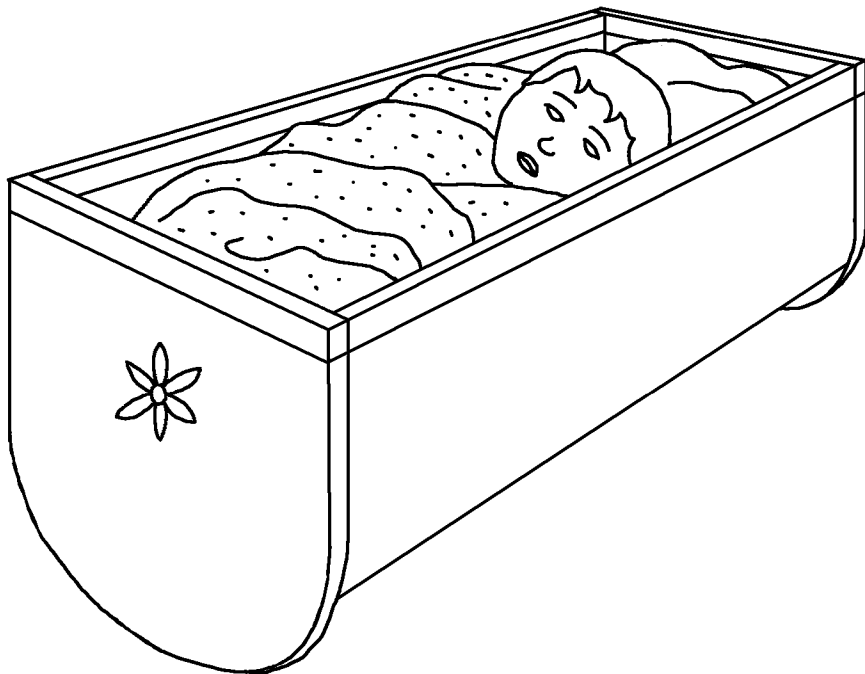



Daut nääkjste Joa  
jinkj Hana nich nom  
Vesaumlungs-zelt. Haud  
see äa Vespräakjen  
vejäten? Nä, Hana wull  
wachten bat Samuel  
groot jenuach wia toom  
em Vesaumlungs-zelt  
wonen, un Eli halpen  
Gott deenen. Dan  
brocht see am  
doahan.







Gott ieed Hana  
daut see soo tru  
wia. Gott jeef  
Hana noch dree  
Junges un twee  
Mejales. Jieda  
Joa jinkj Hana no  
daut Vesaumlungs-  
zelt toom Gott  
aunbäden - un  
Samuel een nieet  
Hamd brinjen.





Doa wieren noch aundre waut Eli  
holpen. Hee haud twee Säns, Hofni  
un Pinhas, waut doa schauften. See  
deeden schljachte Dinja waut nich  
em Tempel jehieeden. Eli prachad  
an see sullen bätä doonen, oba see  
horchten nich.  
De Lied wisten  
daut daut  
orrajcht wia.



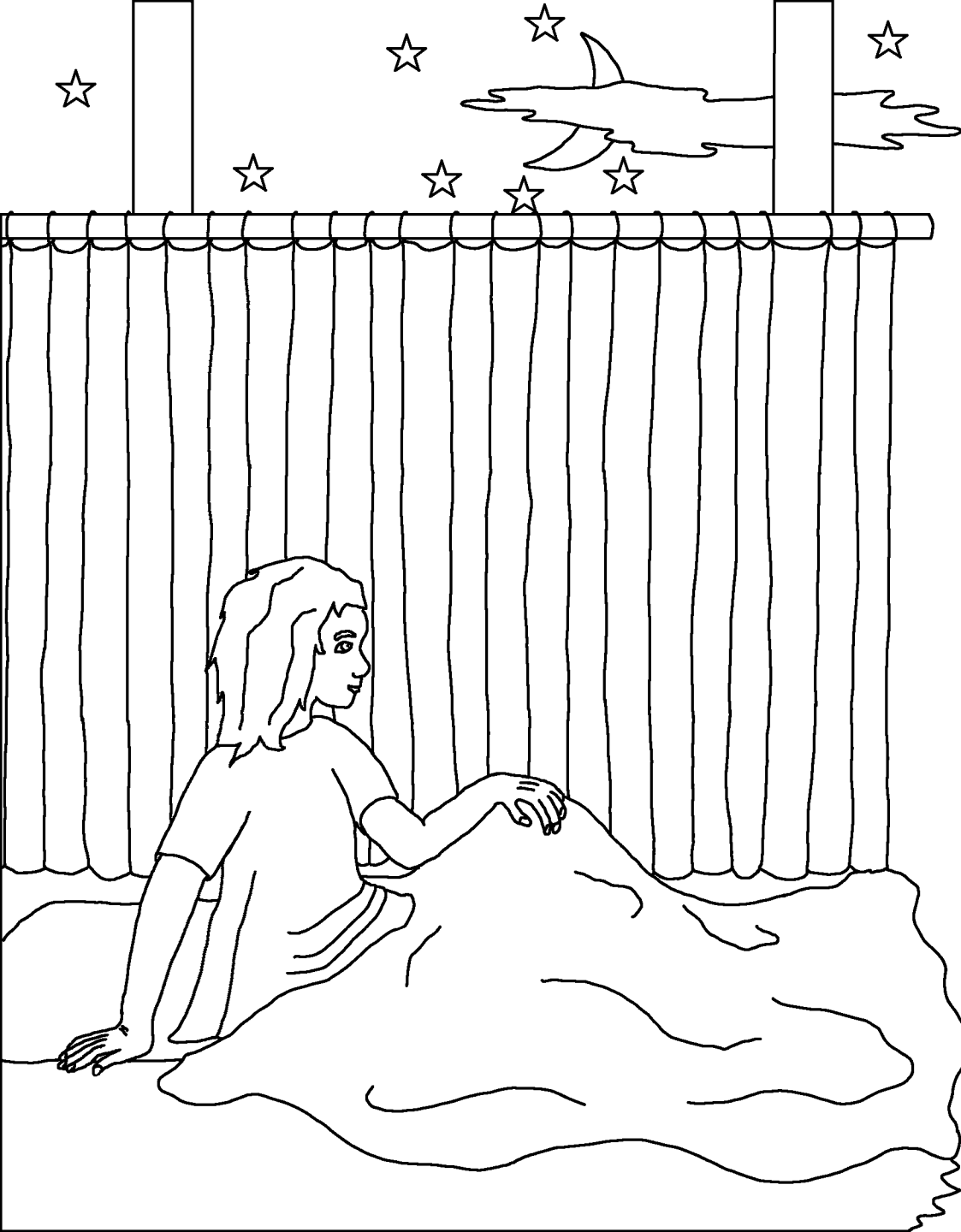

Eene Nacht hieed Samuel eene Stemm am roopen. Hee docht daut wia Eli, un hee jinkj no am un säd, "Hia sie ekj." "Ekj hab die nich jeroopt," säd Eli. Dit passieed dree mol. Dan wist Eli daut Gott Samuel roopt.



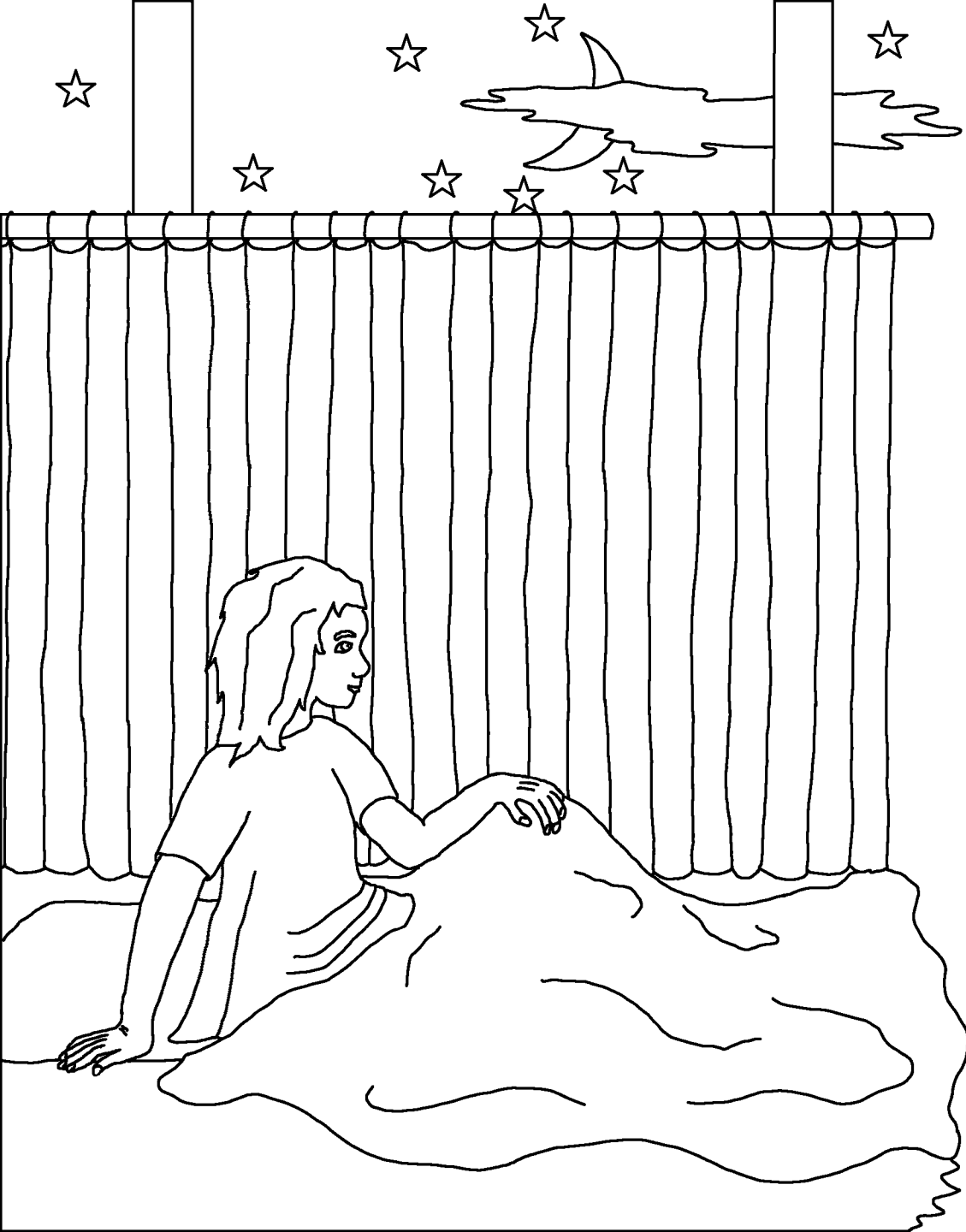

Eli säd, "Wan hee  
wada roopt dan  
saj, 'Räd Har,  
dien Deena  
horcht.'" Un  
Gott roopt  
noch wada un  
jeef Samuel  
eene wichtje  
Norecht.



Zemorjes roopt Eli Samuel. Hee wull weeten waut  
de Har am jesajcht haud. Samuel säd am aules, wan  
daut uk waut schwoaret wia. Gott wudd Eli un siene  
Famielje ombrinjen wäajen Hofni un Pinhas soo  
schlajcht wieren.



Waut Gott jesajcht haud, kjeem soo.  
En eenen Kjrigh met de Filista,  
druagen Hofni un Pinhas Gott siene  
Kjist met de Israelitische Soldoten.  
De Fient neem de Kjist, un  
muaken Hofni un Pinhas  
doot, un vâl Soldoten.  
Aus Eli daut hieed, waut  
jeworden wia, foll hee  
von siene Benkj, bruak  
sien Jenekj un  
storf dän Dach.

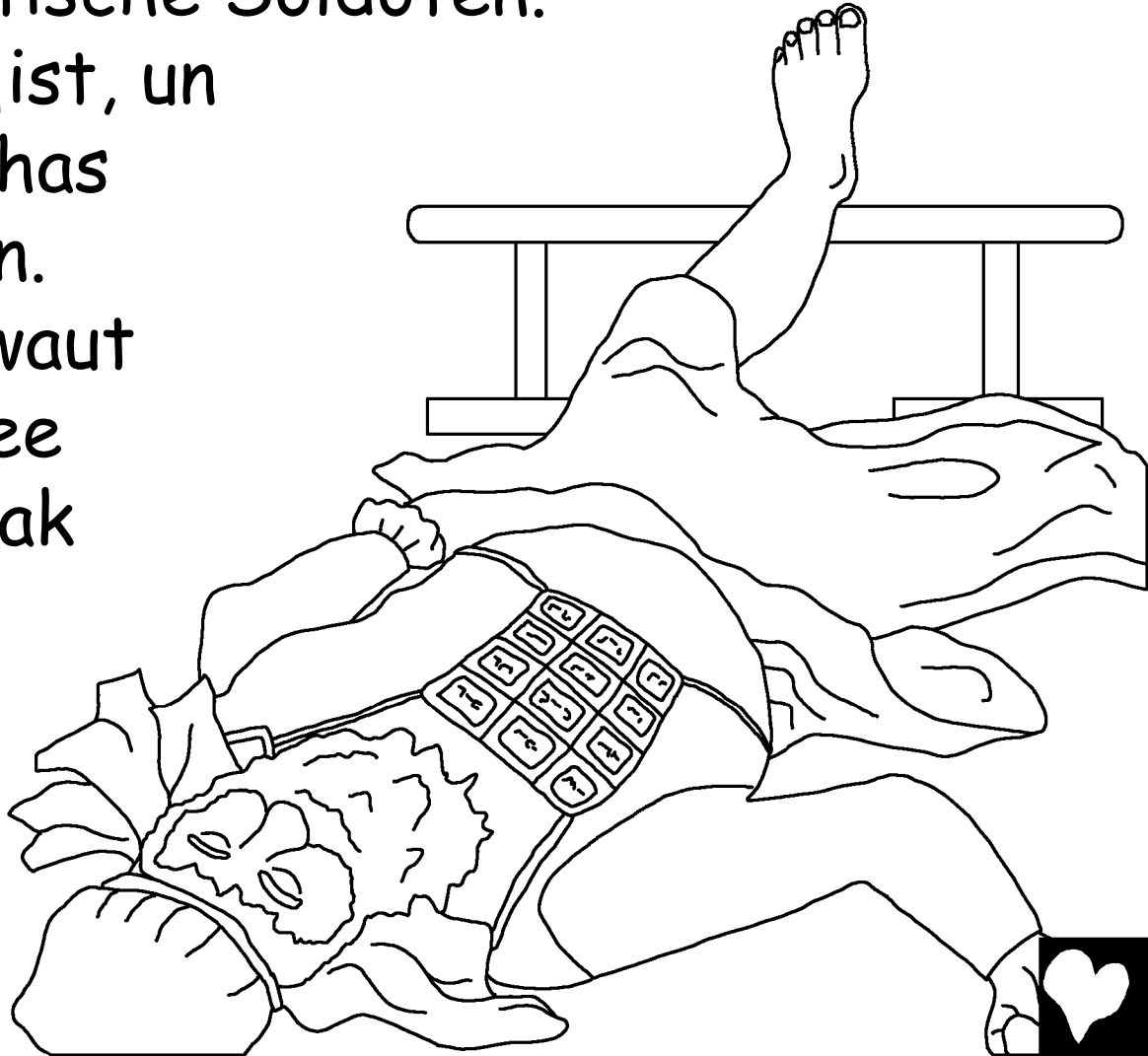

Gott siene Kjist brocht Trubbel fa de Filista. See  
saden dee bie äaren Jetzen, Dagon. Dän näakjsten  
Morjen wia de Dagon Jetzen opp sien Jesecht  
jefollen. De Filista hoowen am opp, oba de  
näakjste Nacht foll dee wada un bruak en Stekja.

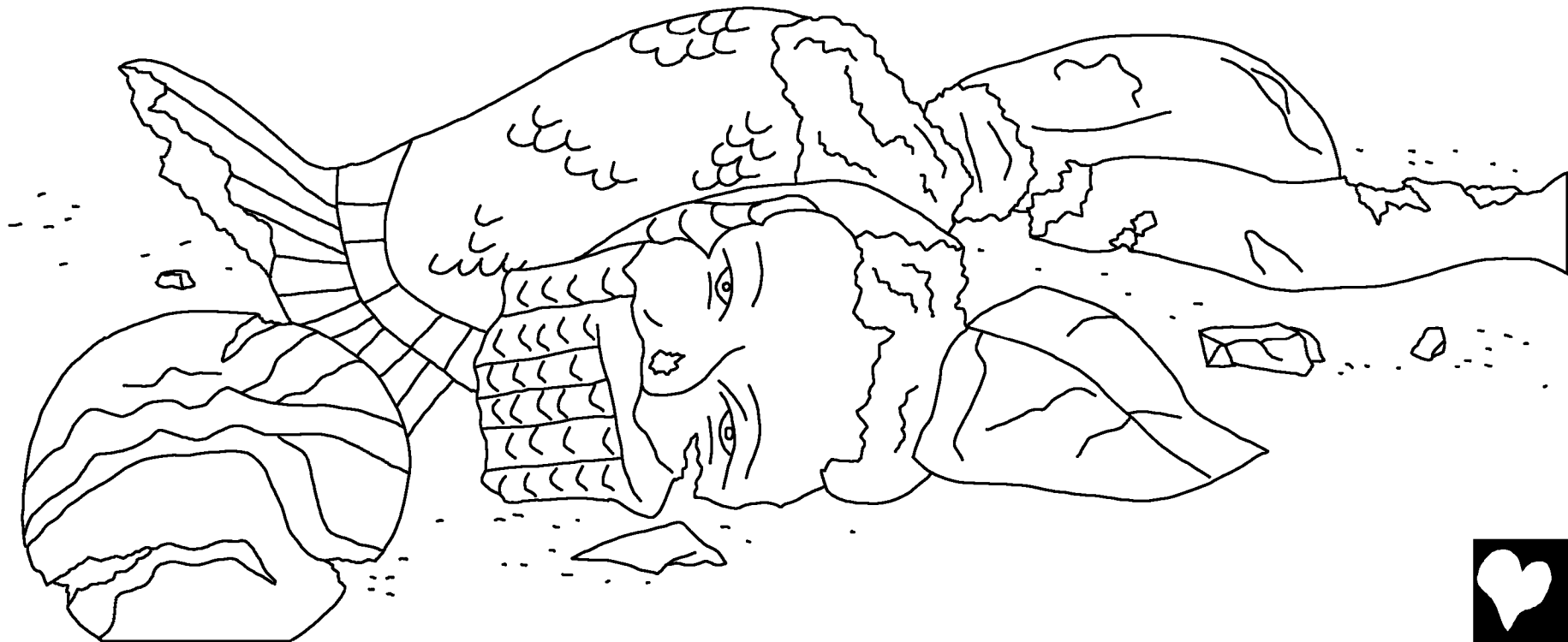



Nu kjeem doa Krankheit  
un Doodes mank de Filista.  
See wullen seenen auf Gott  
an stroft. See saden de  
Kjist opp een Woagen un  
spaunden twee Kjeej  
veropp. See hilden de  
Kjalwa. "Wan de Kjeej  
no Israel gonen un de  
Kjalwa hinjen loten,  
dan weet wie daut Gott  
dit jedonen haft," säden  
see. De Kjeej jinjen.





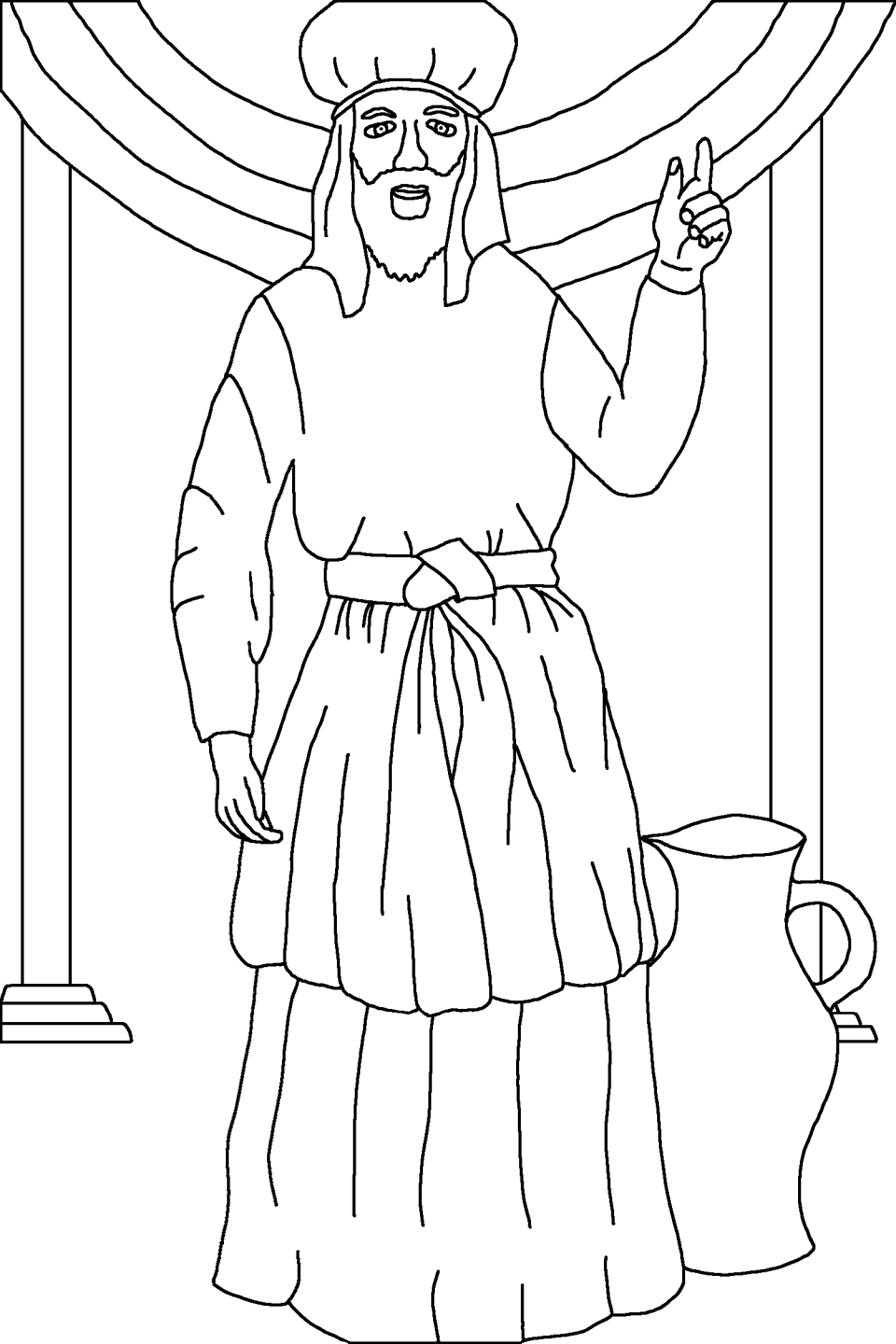

Samuel wia nu  
oppjewossen, un hee  
säd de Israeliten,  
"Wan jie met jun  
gaunset Hoat trigj  
no däm Harn komen  
... dan woat hee junt  
ut de Filista äare  
Macht raden."  
De Menschen  
jehorchten am, un  
Har hilt de Filista  
trigj en Samuel  
siene Tiet.



Samuel, Een Jung dee Gott deend  
Eene Jeschicht von en daut Wuat Gottes,  
de Bibel

finjt eena en

1.Samuel 1-7

"Wan dien Wuat openboat woat,  
jeft daut Licht." Psalm 119:130



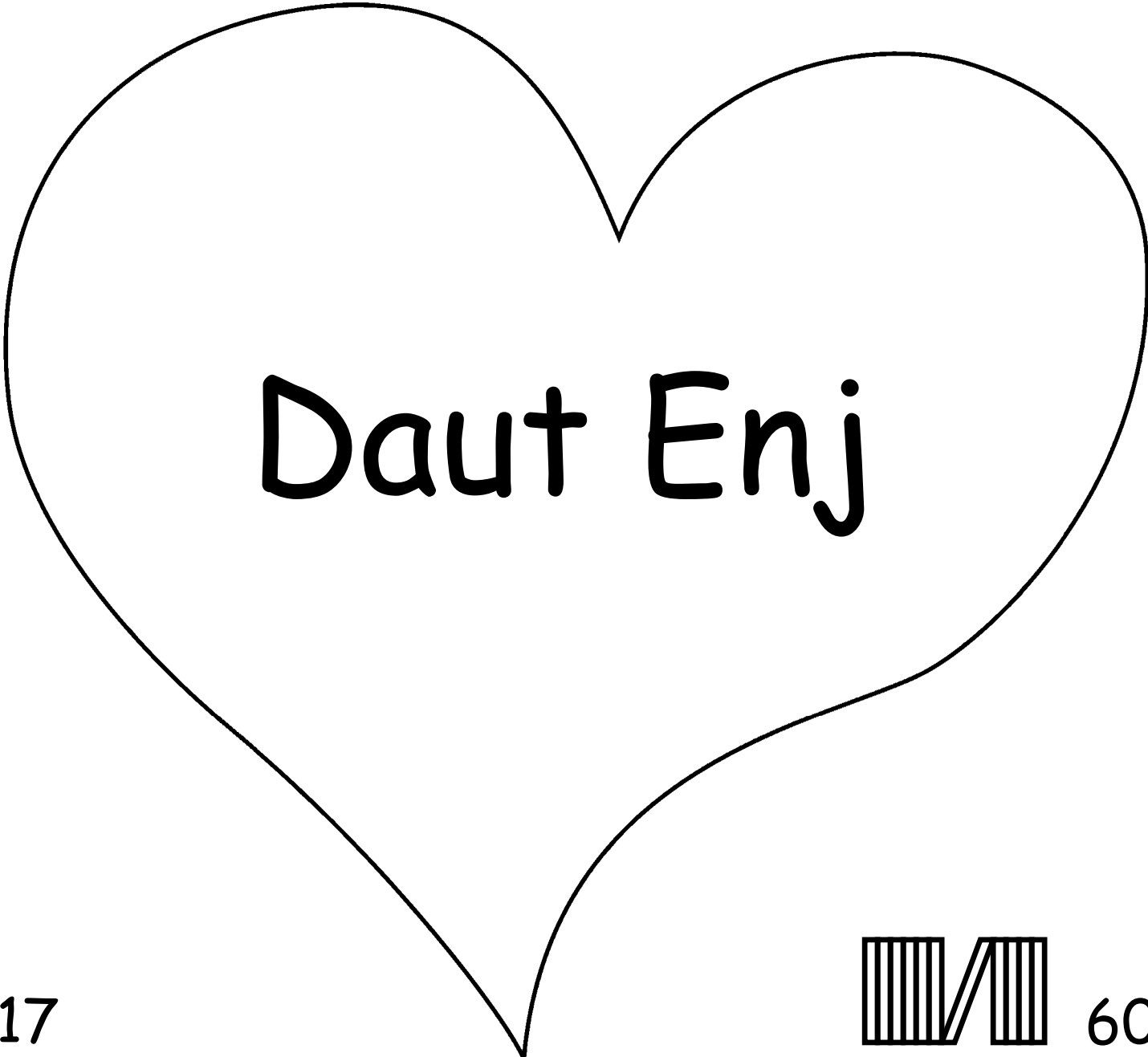

Daut Enj



Dise Biblische Jeschicht sajcht ons von onsen wundascheenen Gott, see ons jemoakt haft un ons well kjanenlieren.

Gott weet daut wie schlaichtet jedonen haben, waut hee Sind nant. De Strof fa Sind es de Doot, oba Gott siene Leew fa ons es soo groot, daut hee sienen eensjen Sän, Jesus, schekjt, daut hee aum Kjriez stoawen sull un de Strof fa onse Sind nämen sull. Dan stunt Jesus vom Doot opp, un fua no sien Tus em Himmell! Wan du dän Gloowen aun Jesus hast, un am frajchst diene Sind to vejäwen, dan deit hee daut! Hee kjemt dan un läft en die, un du woascht opp emma met am läwen.

Wan du dit jleewen kaust, dan saj to Gott:  
Leewa Jesus, ekj jleew daut du Gott best, un worscht een Mensch toom fa onse Sind to stoawen, un daut du nu wada läfst. Komm en mien Läwen un vejeff mie miene Sinden, soo daut ekj nu nieet Läwen haben kaun, un noch emol opp emma no die kom. Halp mie daut ekj die jehuarsom sie, un fa die läw aus dien Kjint. Amen.

Lass de Bibel un räd jieda Dach met Gott! Joh. 3:16

