

Bibel fa Kjinja
brinjt junt

Jona un de Groota Fesch



Jeschräwen von: Edward Hughes
Jemolt von: Jonathan Hay
Toom Pauss jestalt von: Mary-Anne S.
Äwasat von: Ed Zacharias
Hääjestalt von: Bible for Children
www.M1914.org

BFC
PO Box 3
Winnipeg, MB R3C 2G1
Canada

©2022 Bible for Children, Inc.

Jesazlich: Du doascht dise Jeschicht oppnämen ooda drekjen,
soo lang aus du dee nich vekjafst.



Lang trigj läwd doa een Maun, Jona,
en Israel. Een Dach säd Gott, Jona
sull no Ninive gonen. Ninive wia
eene groote Staut met eenen
grooten Kjennich. Jona sull de
Lied sajen
daut Gott

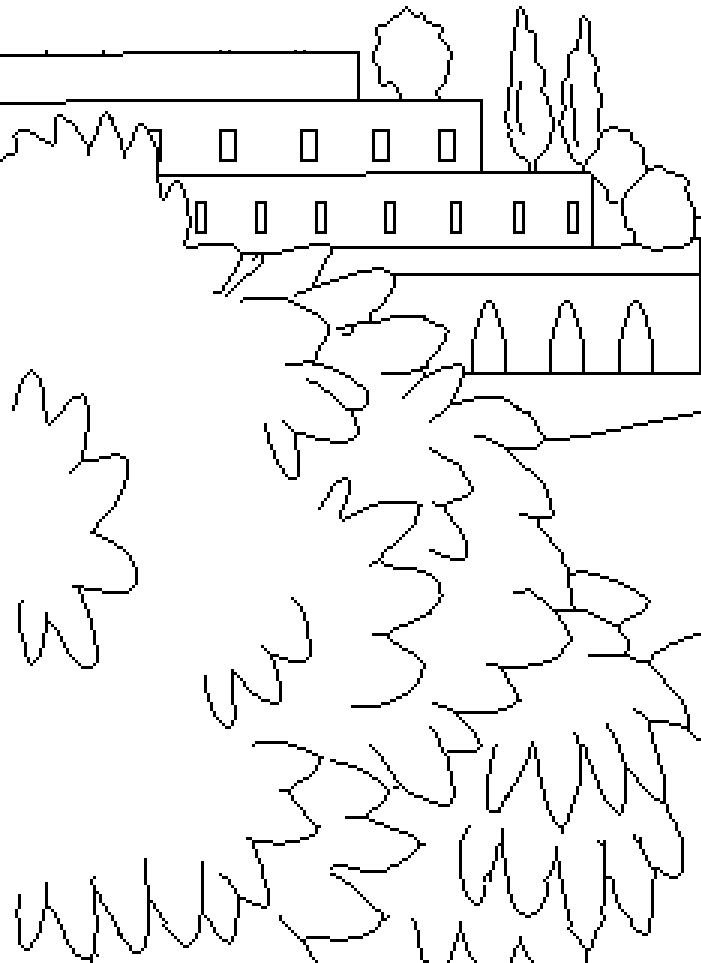

wist woo
schlajcht
see wieren.

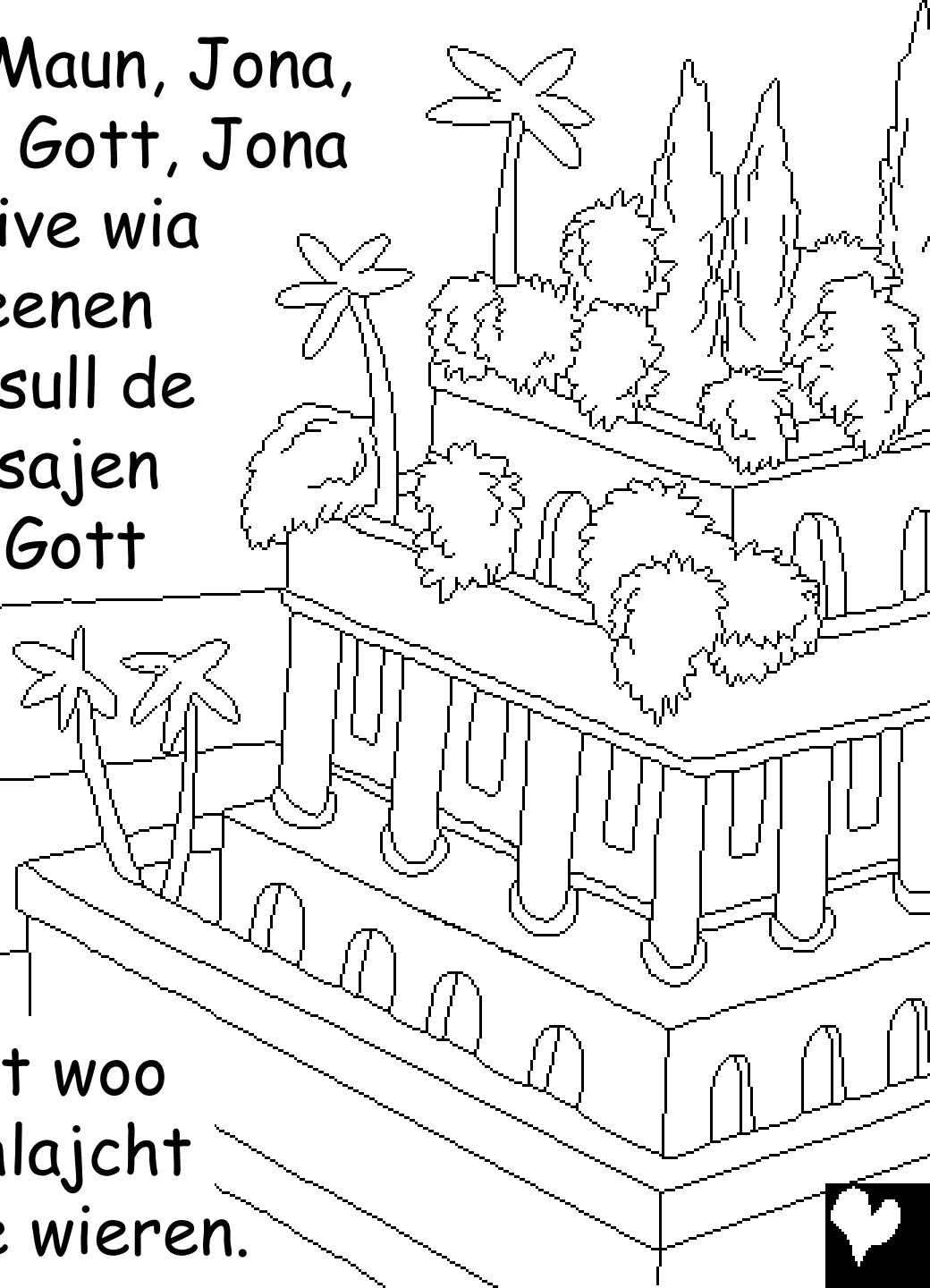

Jona jehorcht Gott nich! Enne
Städ daut hee no Ninive jinkj,
stieech hee en een Schepp daut
am no Tarsis naum. Daut wia
noch wiet auf von Ninive.

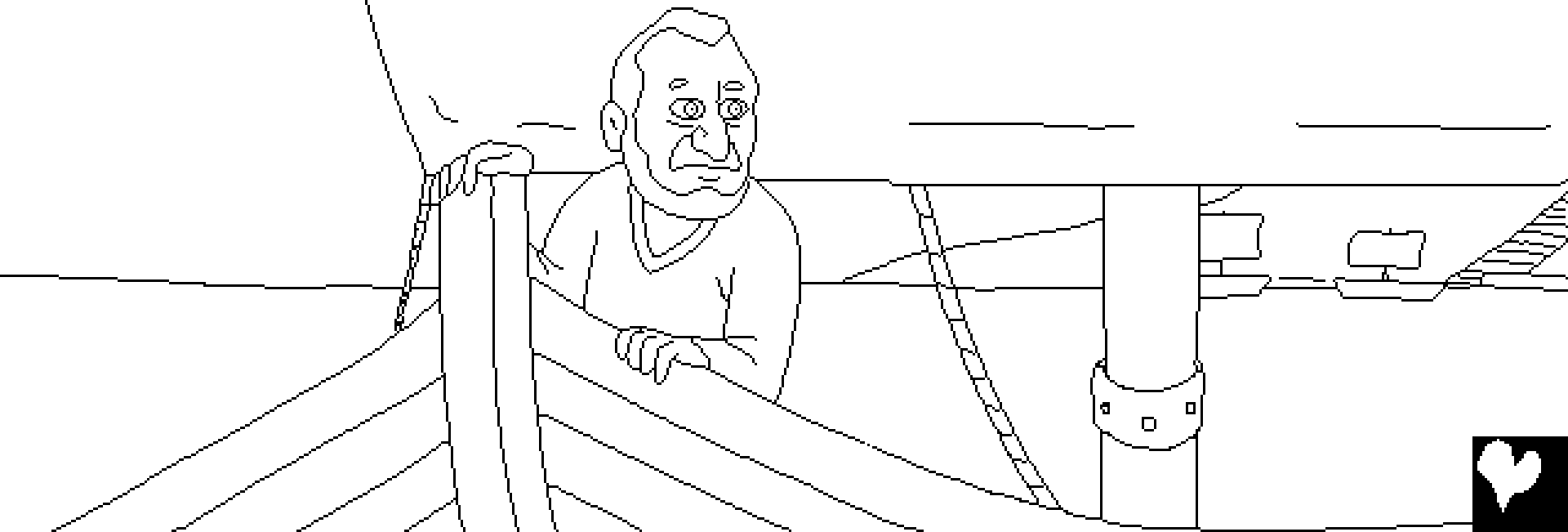

De HAR Gott schekjt eenen stoakjen Storm-Wint
oppem Mäa nopp. De Seemana enjst, daut daut
Schepp zwei-bräakjen un unjagonen wudd.

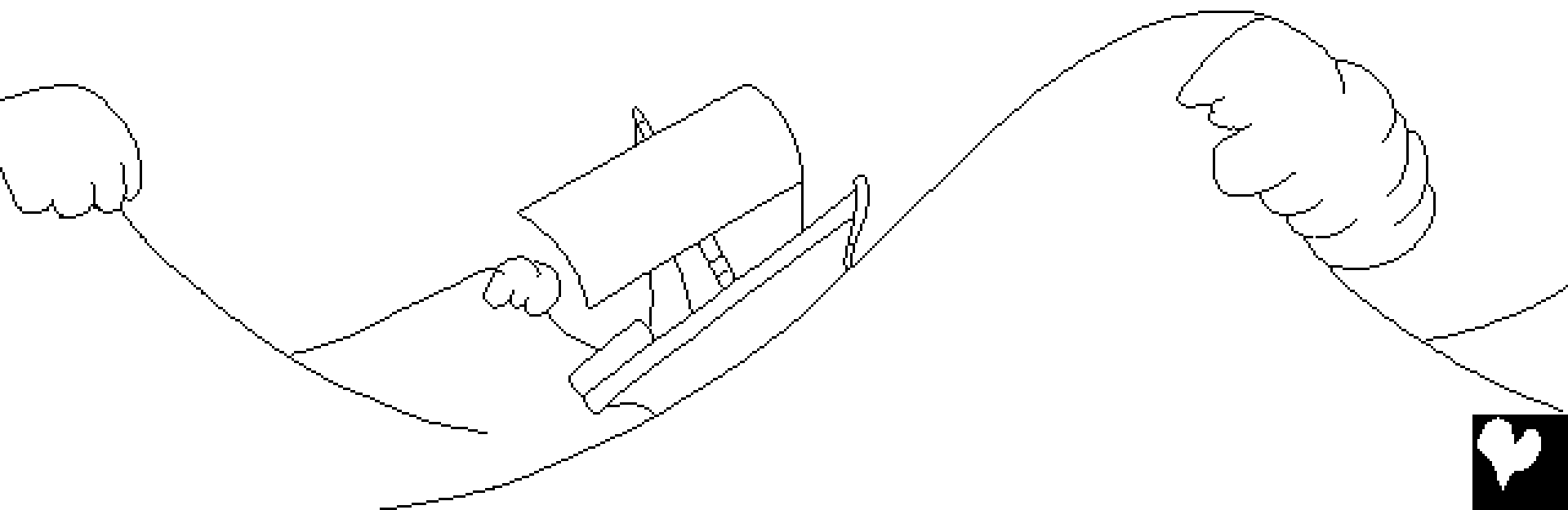

De Storm wort eegol schlemma. Gauns ve-enjst
bäden de Seemana jieda äaren Gott aun. See
schmeeten de Fracht em Mä toom daut Schepp
leichta moaken; oba daut holp nuscht.

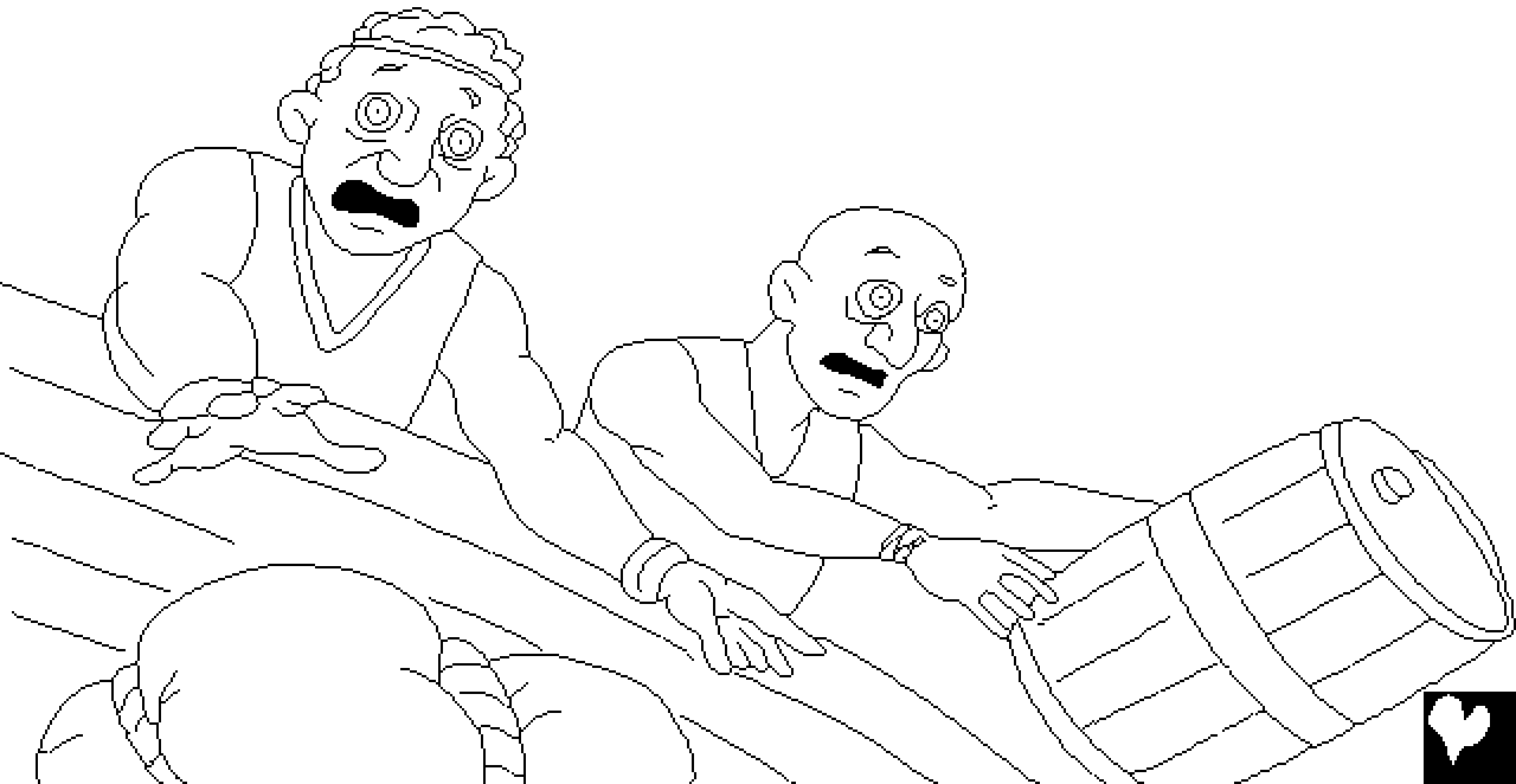

Bloos Jona deed nich bäden. Hee haud sikj doljelajcht un schleep. De Kapitän funk am, un säd, "Wuarom schlapst du? Sto opp, un bäd dienen Gott aun. Veleicht denkjst hee aun ons un halpt daut wie nich unja-gonen."

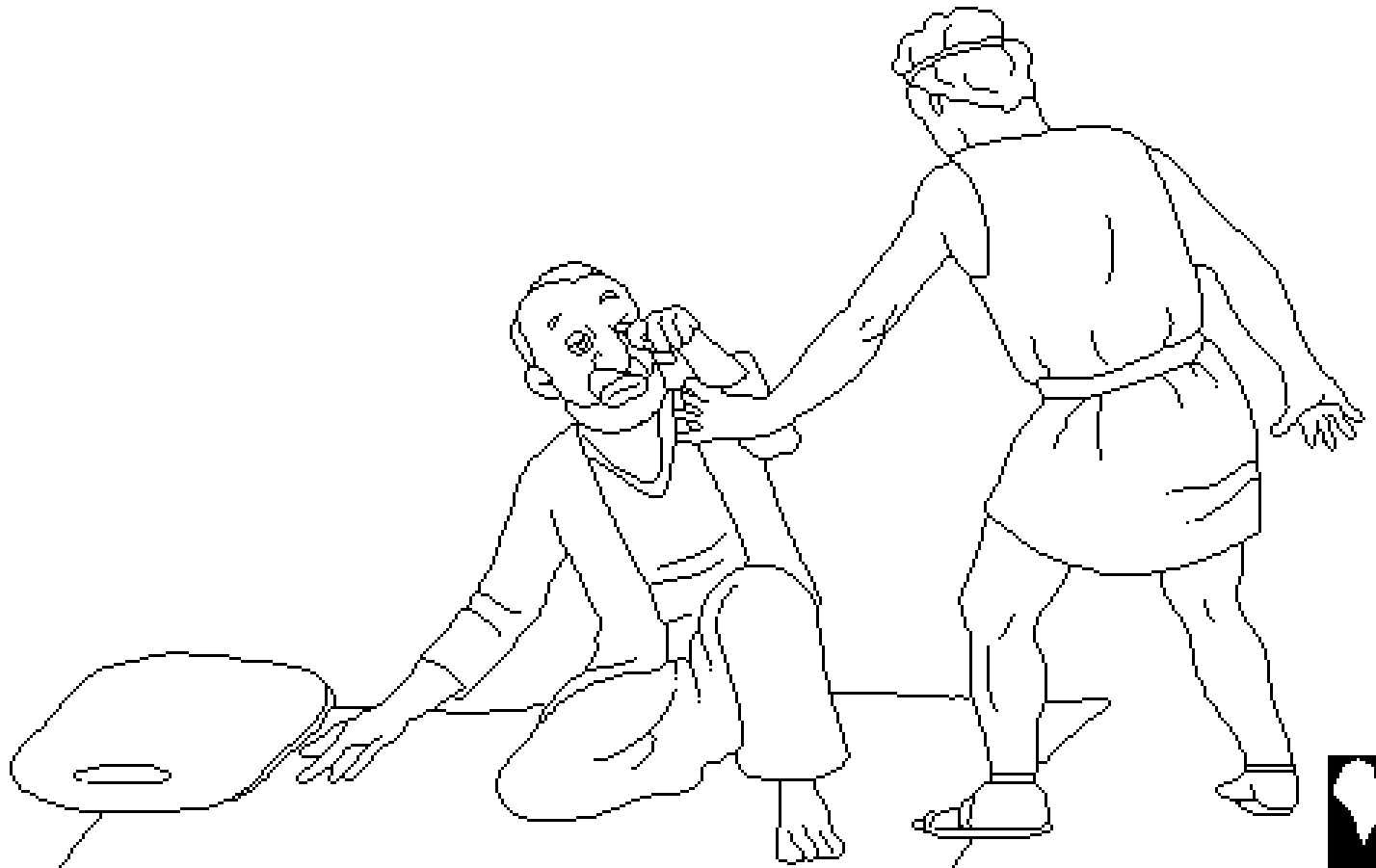

De Seemana meenden Jona haud waut to doonen met äaren Trubbel. Jona säd an, daut hee vom HARN wajch-rand. See fruagen, "Waut sell wie to die doonen, soo daut de Storm äwa jeit?" Hee säd, "Nämt mie, un schmiet mie em Mäa. Ekj jleew dis Storm kjeem wäajen mie."



De Seemana wullen
nich Jona em Wota
schmieten. See
roodelden sea toom
nom Launt komen;
oba see kunnen
daut nich. Doa
wia bloos een
Rot!



Ieescht bäden de Seemana,
daut Gott an
daut vejäwen
sull, un dan
schmeeten
see am em Mäa.
Aus Jona en de Walen
veschwunk, veschwunk uk de
Wint un daut Mäa wort stell.
Dit wundad de Seemana
sea. Bloos Gott kunn
soont doonen. See
hauden Forcht fa
däm HARN un
bäden am aun.



Oba de onjehuarsoma
Jona must sikj uk
wundren. Hee
docht daut hee
wudd vedrinkjen
motten. Daut
wudd uk jeworden
sennen wan Gott
nich eenen aundren
Plon jehaut haud.



De HAR haud eenen grooten Fesch
jebrocht toom Jona oppschlucken.
Nu wia dee doa, un Jona wia boolt
em Fesch sien Buck. Hee wia doa
fa dree Doag. Hee haud Tiet
toom denkjen un bäden. Vål Tiet.

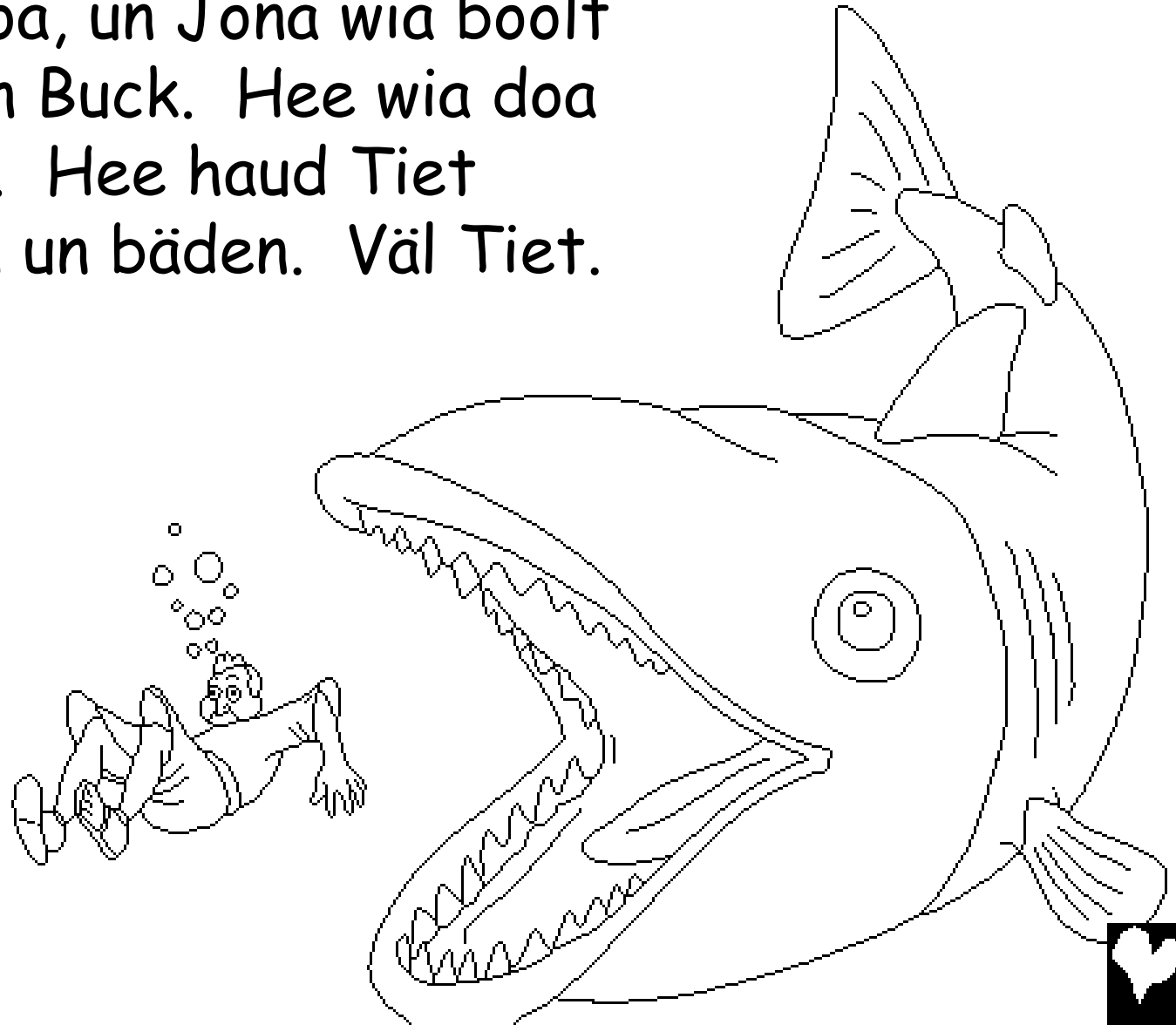

En de dree Doag wort Jona wellich Gott
jehuarsom to sennen. Doamet leet Gott däm
Fesch Jona oppbrinjen, oppem Launt nopp.

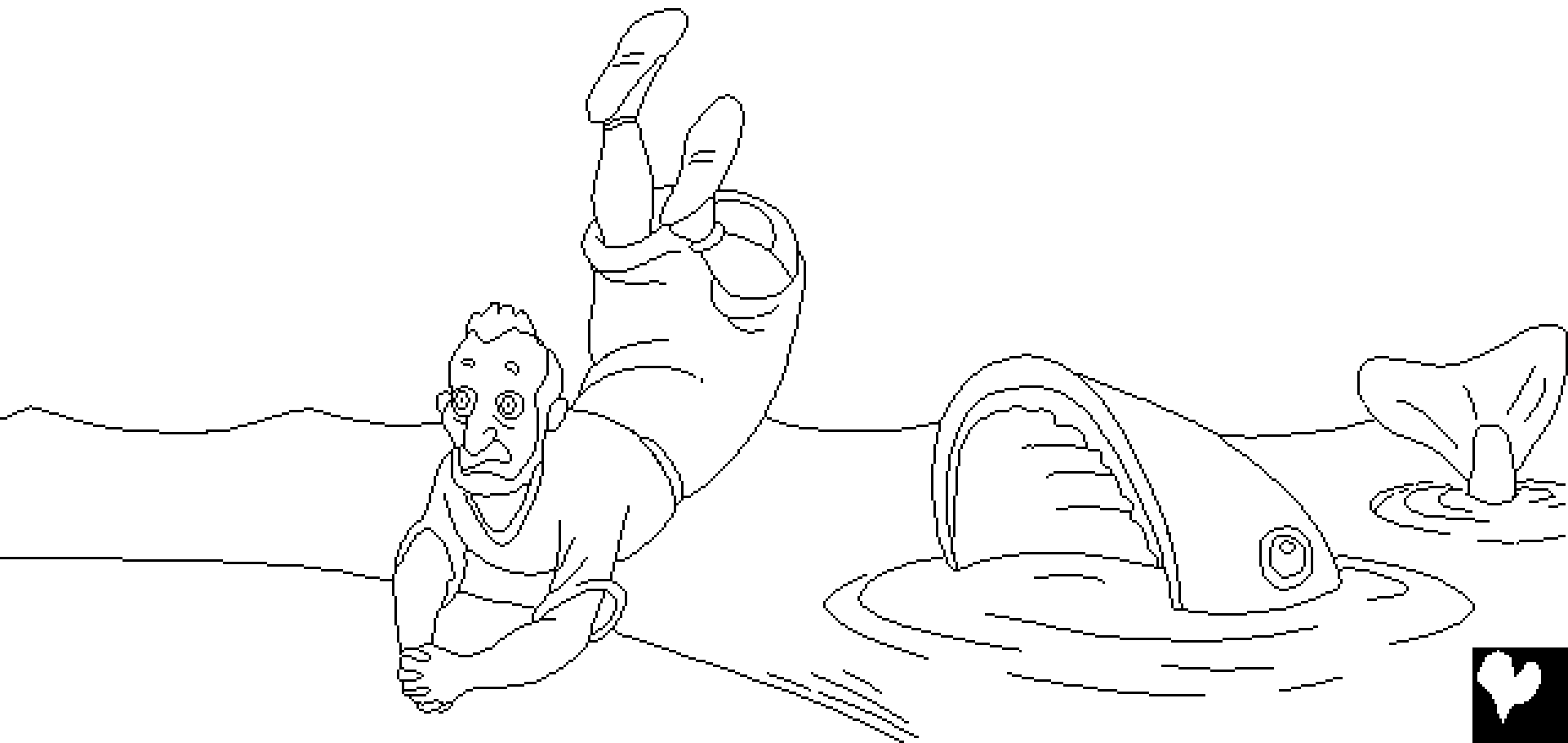

Gott räd wada to Jona, un säd hee sull no
Ninive gonen un prädjen. Ditmol jinkj Jona.
Aus hee enne Staut nenn kjeem säd hee,
"Noch 40 Doag un dan woat dise Staut
venicht woaren."



De Menschen en Ninive jleewden Gott sien Wuat.
See eeten een poa Doag nuscht un druagen Sak-
kjeeda, wiels an äare Sind soo leet wia. Uk de
Kjennich kjneed ver Gott. Hee veleet sien Troon,
druach Sakkjeeda un saut em Ausch. Hee velangd
daut aule Menschen daut
schlajchte oppjäwen
sullen. See sullen
bäden daut Gott
an vejäwen wudd.

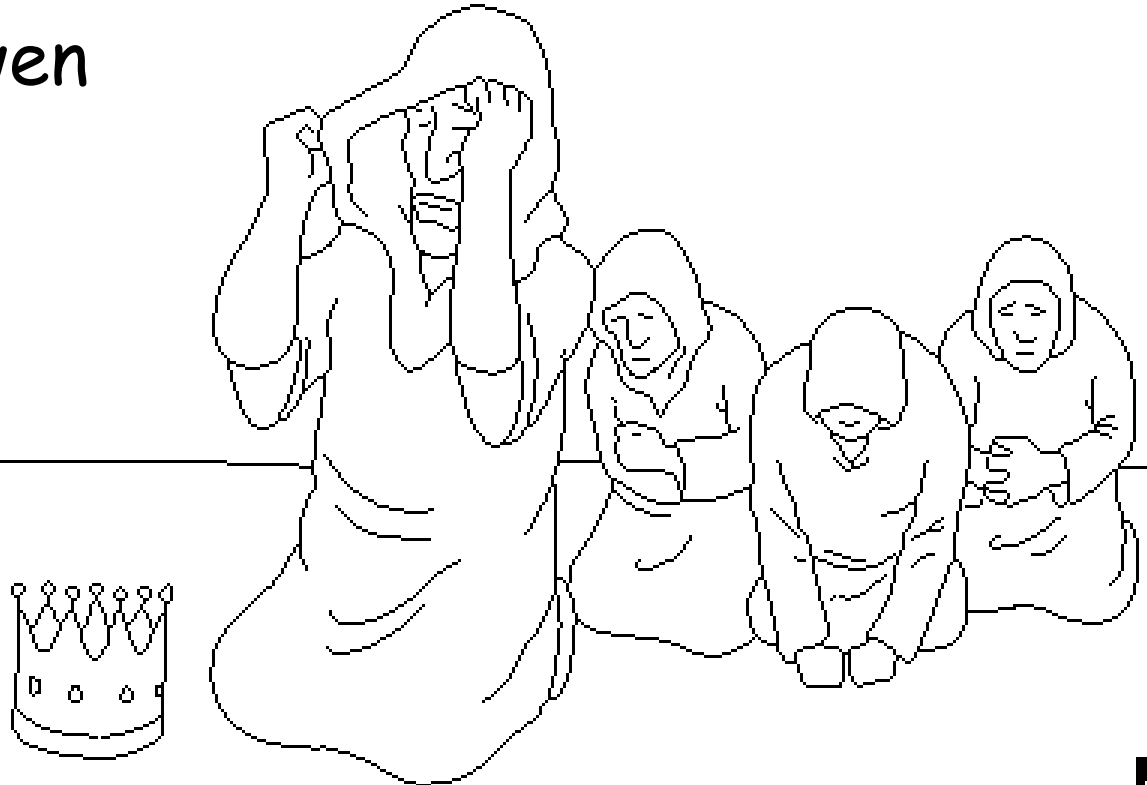

Gott DEED an vejäwen! Daut muak de Lied en Ninive
sea jlekjlich. Gott haud an vejäft. ...

Oba een Maun wia sea
doll. Daut
wia Jona.



Wuarom wia Jona doll?
Hee säd to Gott, "Ekj wist
du wiescht sea jenstich
un deetst die leicht
erboarmen." Jona haud
jewist daut Gott vejeef
dee, waut äare Sind leet
wia, un Gott sien Wuat
jehorchten. Jona haud
waut jaaen Ninive; hee
wull haben daut see nich
vejäft sullen.



Jona wie soo doll äwa Gott, hee säd, "Ekj sie saut vom Läwen. Lot mie doch stoawen."



Jona sad sikj buta de Staut dol toom seenen waut
Gott met Ninive doonen wudd. De HAR leet eene
Plaunt met groote Bläda waussen. Dee kjeem bosich
opp un jeef Jona Schauten von de heete Sonn.



Dän näakjsten Morjen leet Gott een Worm komen
un de Plaunt doot moaken. Dan kjeem een heeta
drieeja Wint, soo daut Jona docht daut hee
stoawen wudd. Jona wort noch dolla.



De HAR säd to Jona, "Waut halpt die daut, die soo to oajren. Die es daut schod äwa eene Plaunt, fa dee du nuscht jedonen hast, un dee du nich daut Läwen jeeftst, eene Plaunt dee eene

Nacht doa wia,
un de näakjste wajch wia.
Woo sull mie daut nich äwa
de Staut Ninive schod
sennen."



Jona un de Groota Fesch

Eene Jeschicht von en daut Wuat Gottes,
de Bibel

finjt eena en

Jona

"Wan dien Wuat openboat woat,
jeft daut Licht." Psalm 119:130



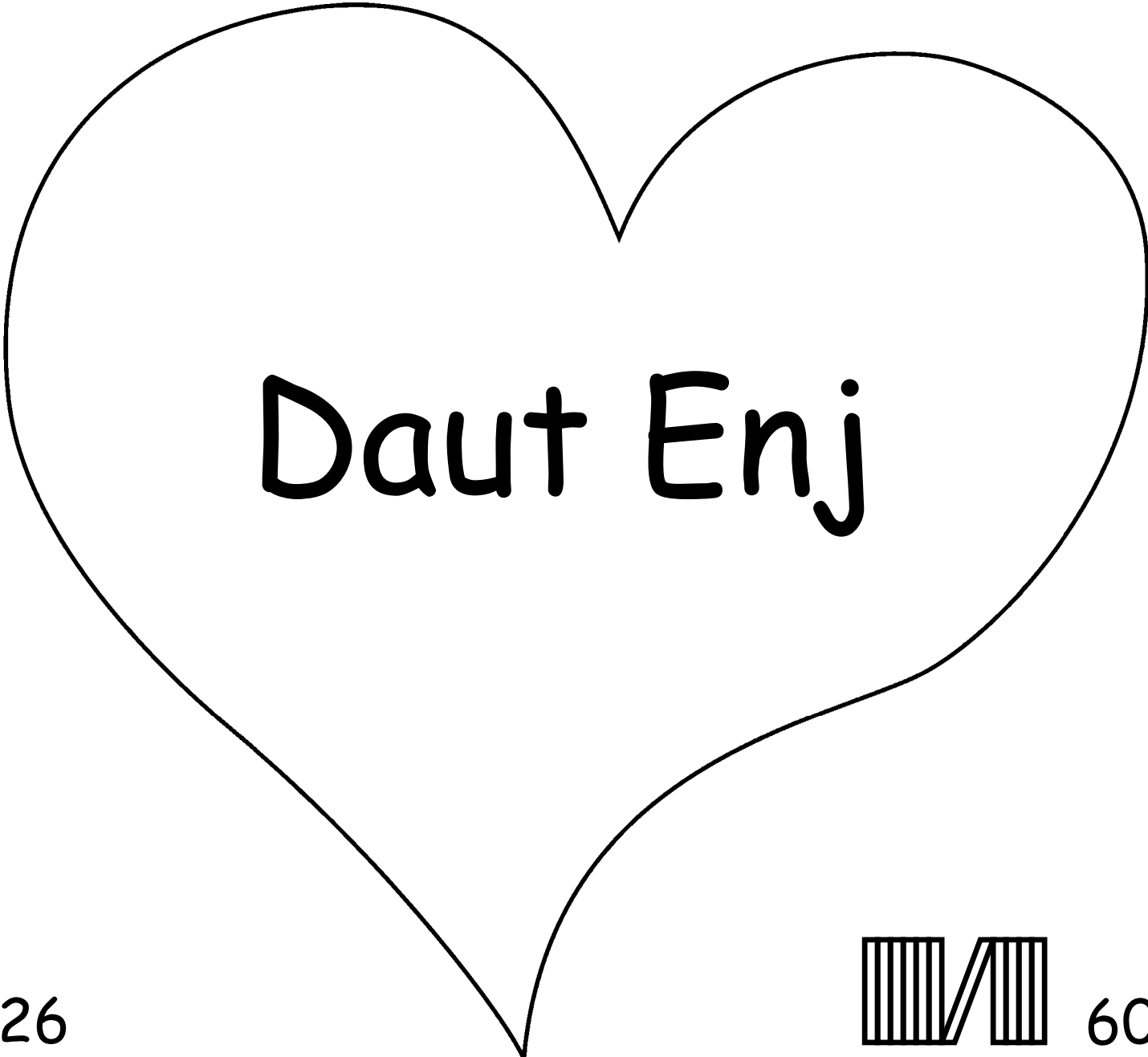

Daut Enj



Dise Biblische Jeschicht sajcht ons von onsen wundascheenen
Gott, see ons jemoakt haft un ons well kjanenlieren.

Gott weet daut wie schlaichtet jedonen haben, waut hee Sind
nant. De Strof fa Sind es de Doot, oba Gott siene Leew fa ons es
soo groot, daut hee sienen eensjen Sän, Jesus, schekjt, daut hee
aum Kjriez stoawen sull un de Strof fa onse Sind nämen sull. Dan
stunt Jesus vom Doot opp, un fua no sien Tus em Himmell! Wan du
dän Gloowen aun Jesus hast, un am frajchst diene Sind to
vejäwen, dan deit hee daut! Hee kjemt dan un läft en die, un du
woascht opp emma met am läwen.

Wan du dit jleewen kaust, dan saj to Gott:
Leewa Jesus, ekj jleew daut du Gott best, un worscht een Mensch
toom fa onse Sind to stoawen, un daut du nu wada läfst. Komm en
mien Läwen un vejeff mie miene Sinden, soo daut ekj nu nieet
Läwen haben kaun, un noch emol opp emma no die kom. Halp mie
daut ekj die jehuarsom sie, un fa die läw aus dien Kjint. Amen.

Lass de Bibel un räd jieda Dach met Gott! Joh. 3:16

