

www.BibleForChildren.org



Jon 14



“Maŋ-ŋaŋunji manebu paio beusembe so maneru goinebi. Anutu manesiŋ gainebi eru noŋ oŋuakon manesiŋ nuru goinebi. Nonde Mamare kae qoruineo pi maŋine boakon pega. Oi so pena ine, ŋoŋore buŋo inji minobo: Nonji oo roperu ŋoŋore ŋeŋe pi baku bobiaŋgabemiŋ.”

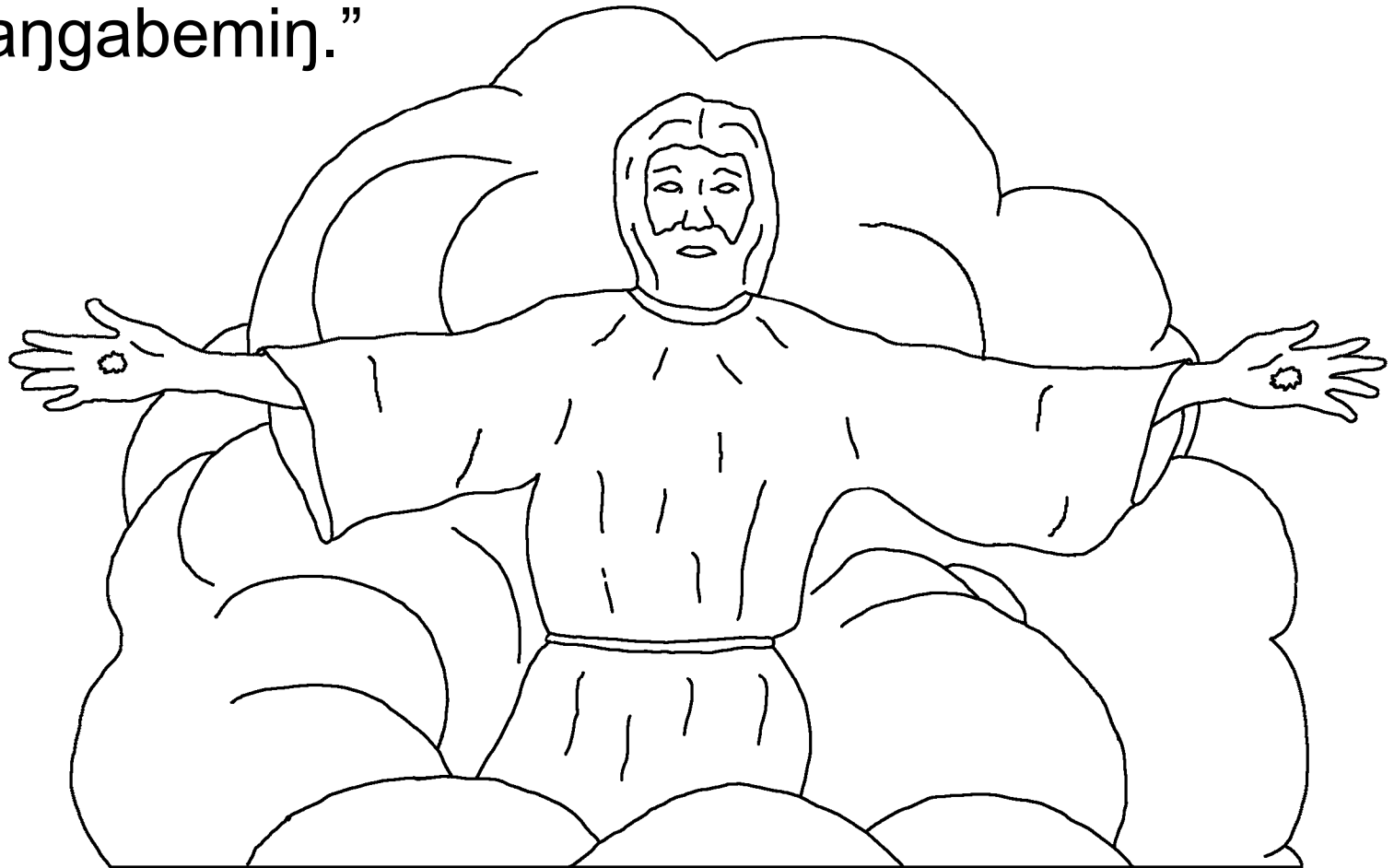

“Nonji bonieru raru roperu ŋoŋore ŋeŋe pi baku bobiangabemiŋyoŋ, nonji kae gobemiŋ, ŋoŋoji oŋuakoŋ noke oo moko goniminde aŋi manego. Ore eru nonji moke kirieru wareru oga yabebe paibe ropenimiŋ.”



Jon nonji n̄on̄ore mān̄kekerisie murān̄ fukego.
Kristoke qakatobe in̄oyon̄unde qoruman̄go rua
nuru on̄ga nareko n̄in̄igoji joisereren̄

enarebi n̄erin̄etatan̄ eego.

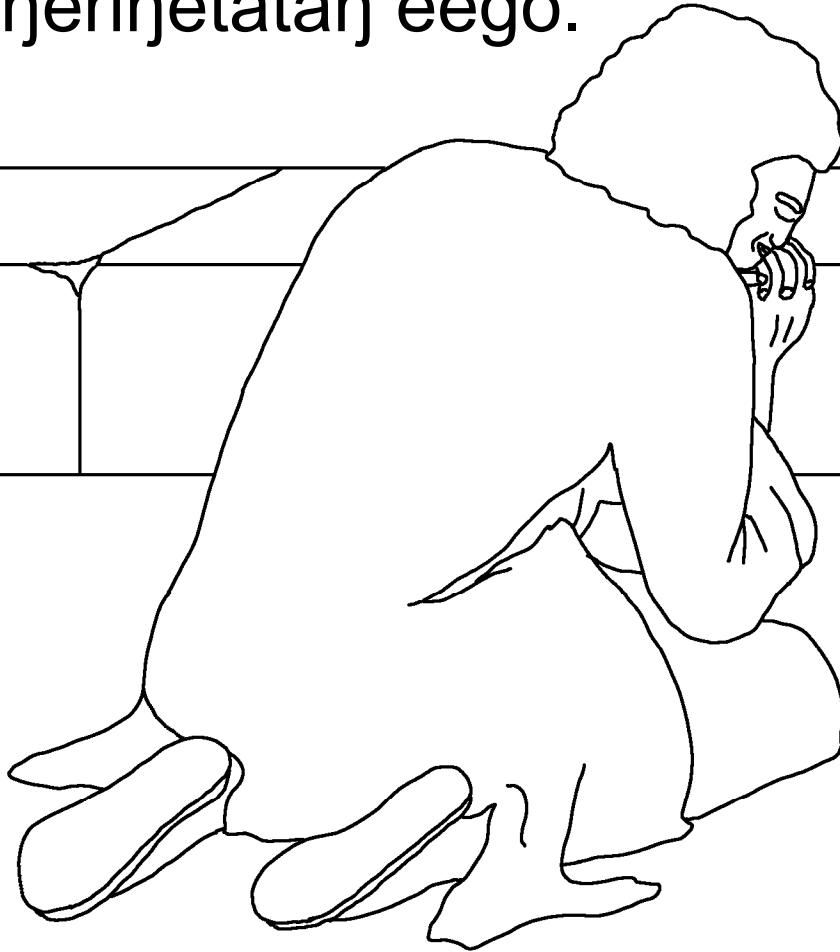

Oi njonjoke moko maneru kariyeru yamenj keku
sanaŋgaru dimago. Anuture Biŋe buŋo
misaueku Yesure funje kitingaku

mitaniŋgaru gobonj ore
oga nuru raru nu tinaine



Patmos oo rua nubi
gobonj.



Oṅu najime oo akonṅ Moro Tiriineji kema nume kobiineji paineo ropeko ya ini ṅonebonṅ: Sombunṅ kae maṅgo morumbonṅ ṅeṅe ṅeko moji oo ṅeya.

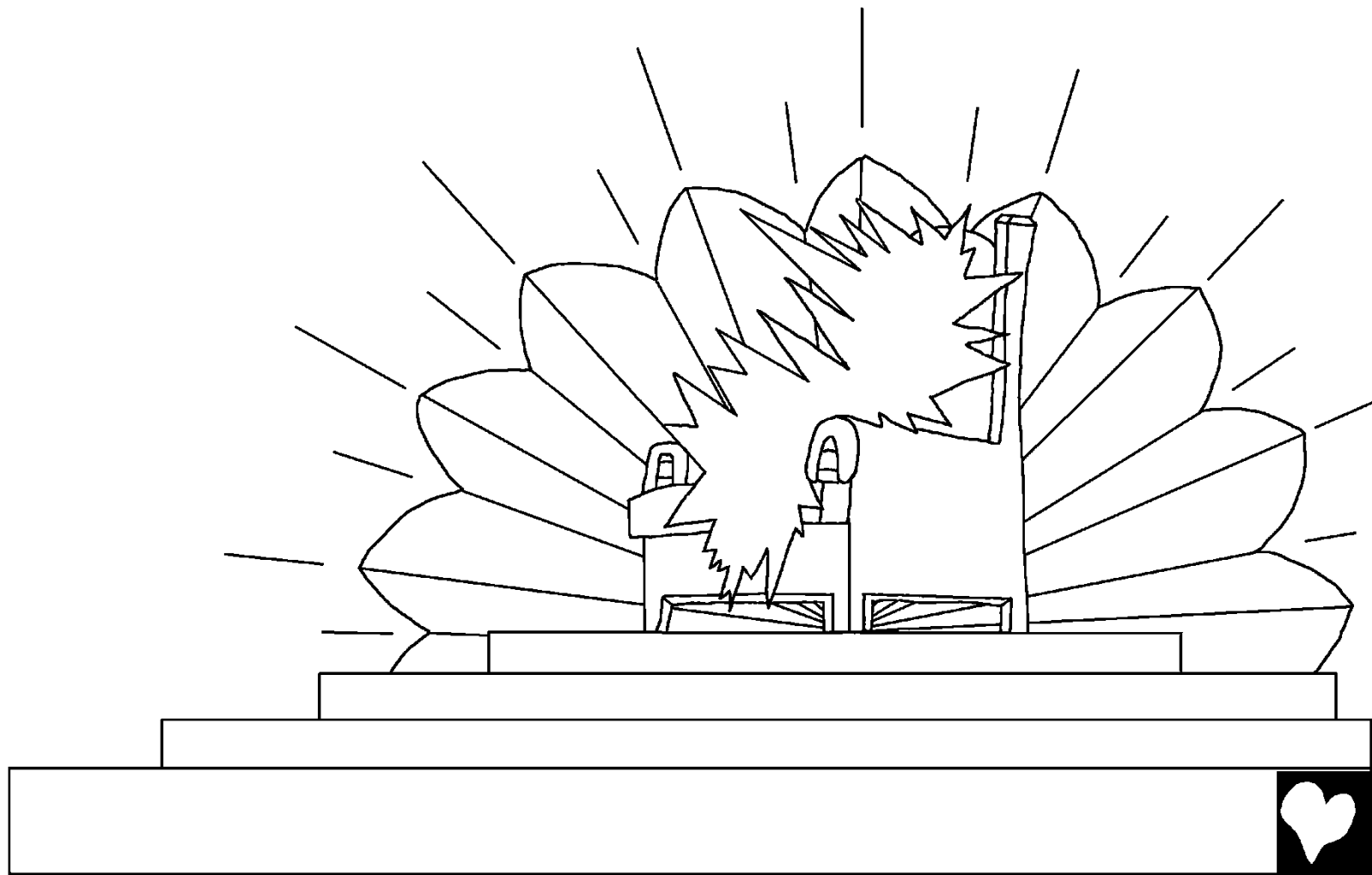

Onu kiki keku mitenḡ gabi kiki
kubu mo yonḡoji inḡ kebi manebonḡ:
Anutuḡi gogoke bofuke yabeya,
yonḡoji sosowo kiki kebi manebonḡ.

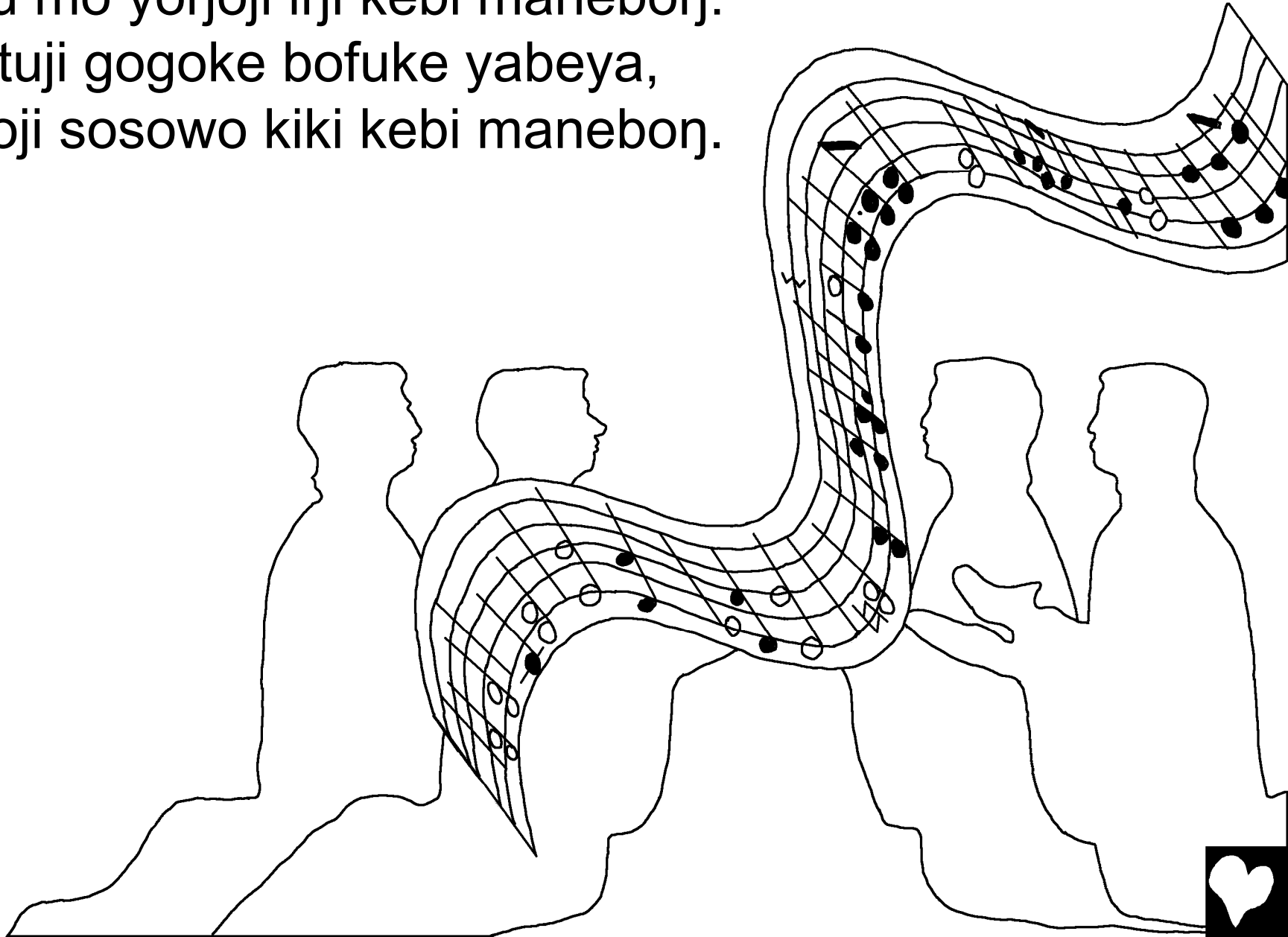

Sombunjo gogobi, morenjo gogobi, kome kaeo eru
koe paiineo gogobi, yonjoji sosowo miyanjun qodureru
kiki inji kebuŋ, “Morumboŋ njeŋeo
neŋa eru Lama madeine niŋoji
noko miteŋ napegobeneŋ. Mifia
Rauine nokoŋe tinabiŋe mi
sogueegobeneŋ. Damaŋ so
kuririquraŋ
natebeneŋ usun
Rauine oi
tatarine tomiri
go ropenimi.”

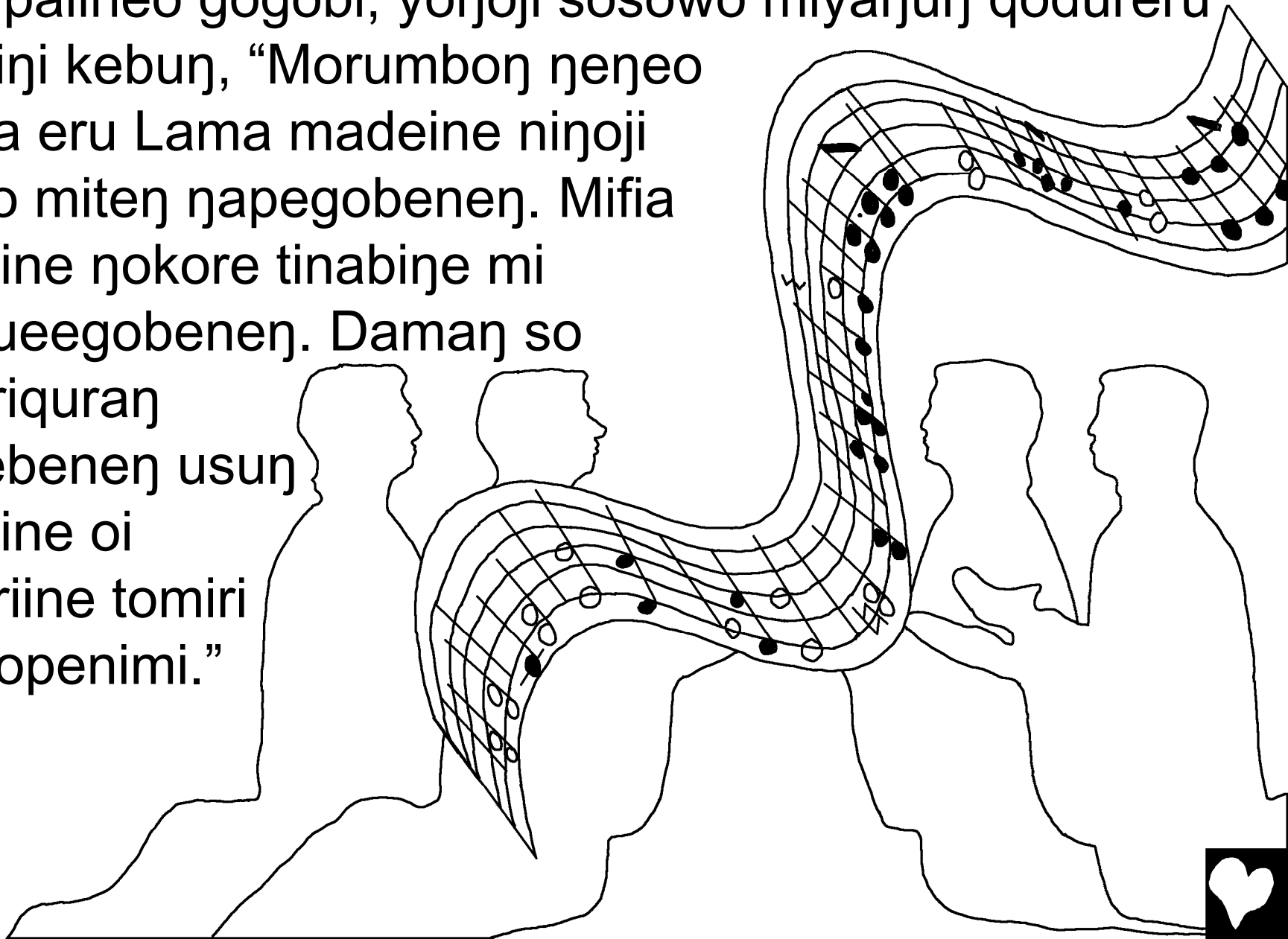

Jerusalem gariine, siti tiriine oi Sombungo Anuture kaeone wakiko ḡoneboḡ. Siti oi bobianḡa forebi ḡone aḡiineke iḡi fukeya: ḡigo suanḡeḡinere mariku ḡone aḡiineke ketebi ḡi biḡeineke ḡodureiḡ ore babajawe ee eru jaueru kuririineke dimaga, siti oiji ore so fukeyo ḡoneboḡ.



Oi ḡoneru dimaku morumbonḡ ḡeḡeone bunḡo mo fukeko manebe sananḡine onḡaku inḡi najiya, “ḡone, Anuture piji oi ḡinḡigo botuyanḡunḡo wakiru pega. Anutuḡi botuyanḡunḡo gome inḡoke gobi inḡoyonḡe ofonḡ Anutuyanḡunḡ fukeru yonḡoke go ropeinḡ.”

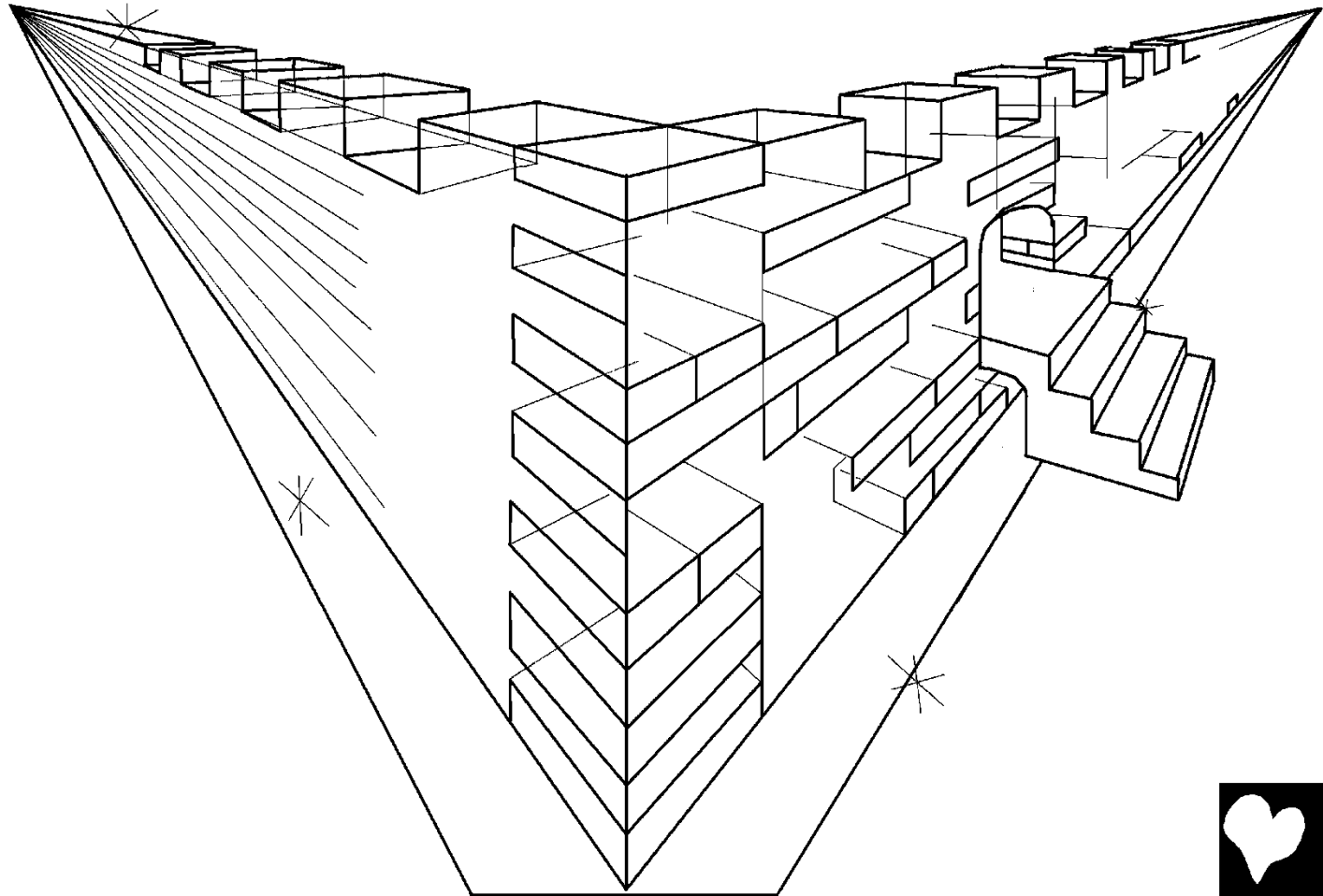

Ore ɲadio Sombuɲ mimereren ɔiji gogo sananinere obu jinɔine nadume Anutu eru Lama madeine yokore morumboɲ ɲeɲeone igomuruɲgaru wareru obu fusiine fukeya. Ore obu ɔi sogo mobeine mobeine buruburuyaɲunke kerisieru tamaegobi, ore so gbagbataenine fukeya.

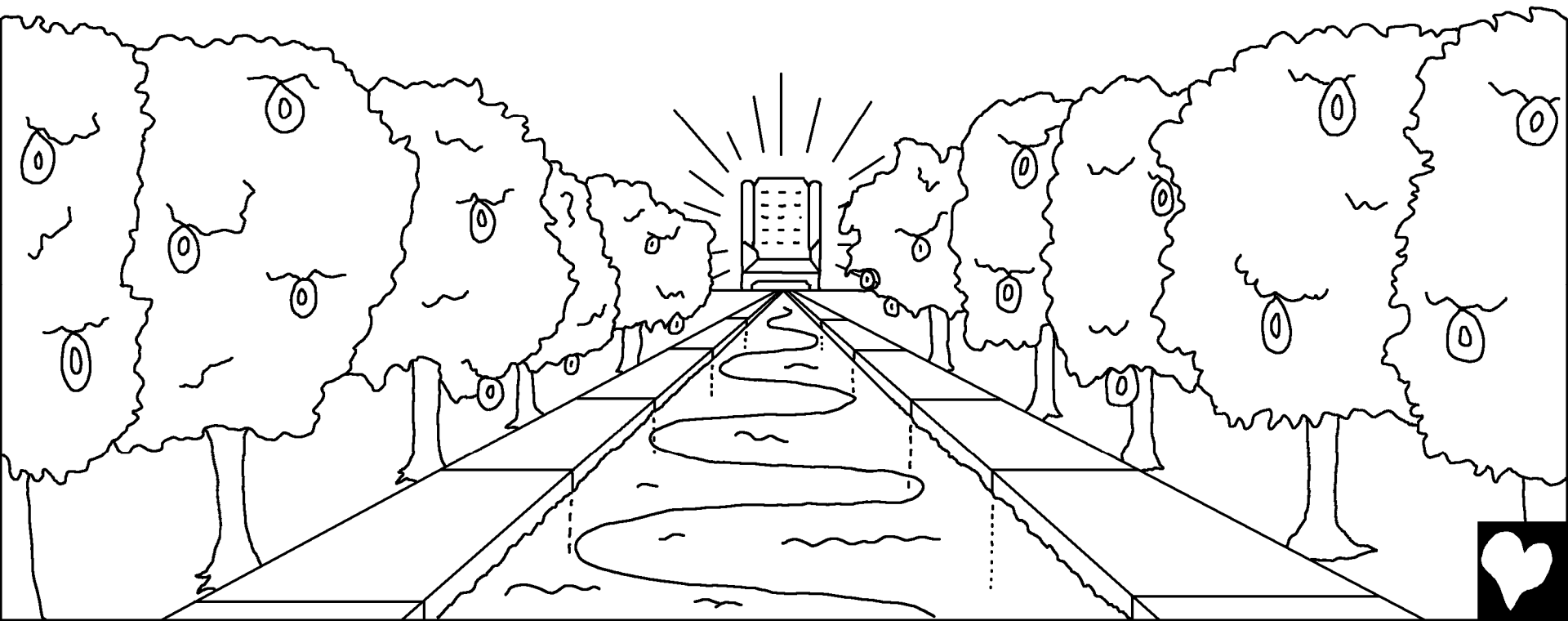

Anuture kuririquaranji siti batamae yareme Lama
madeineji doiyanuᅇ fukega. Ore eru wegi ayonᅇ
tamaenimi ore so embimbiᅇgaegobi.

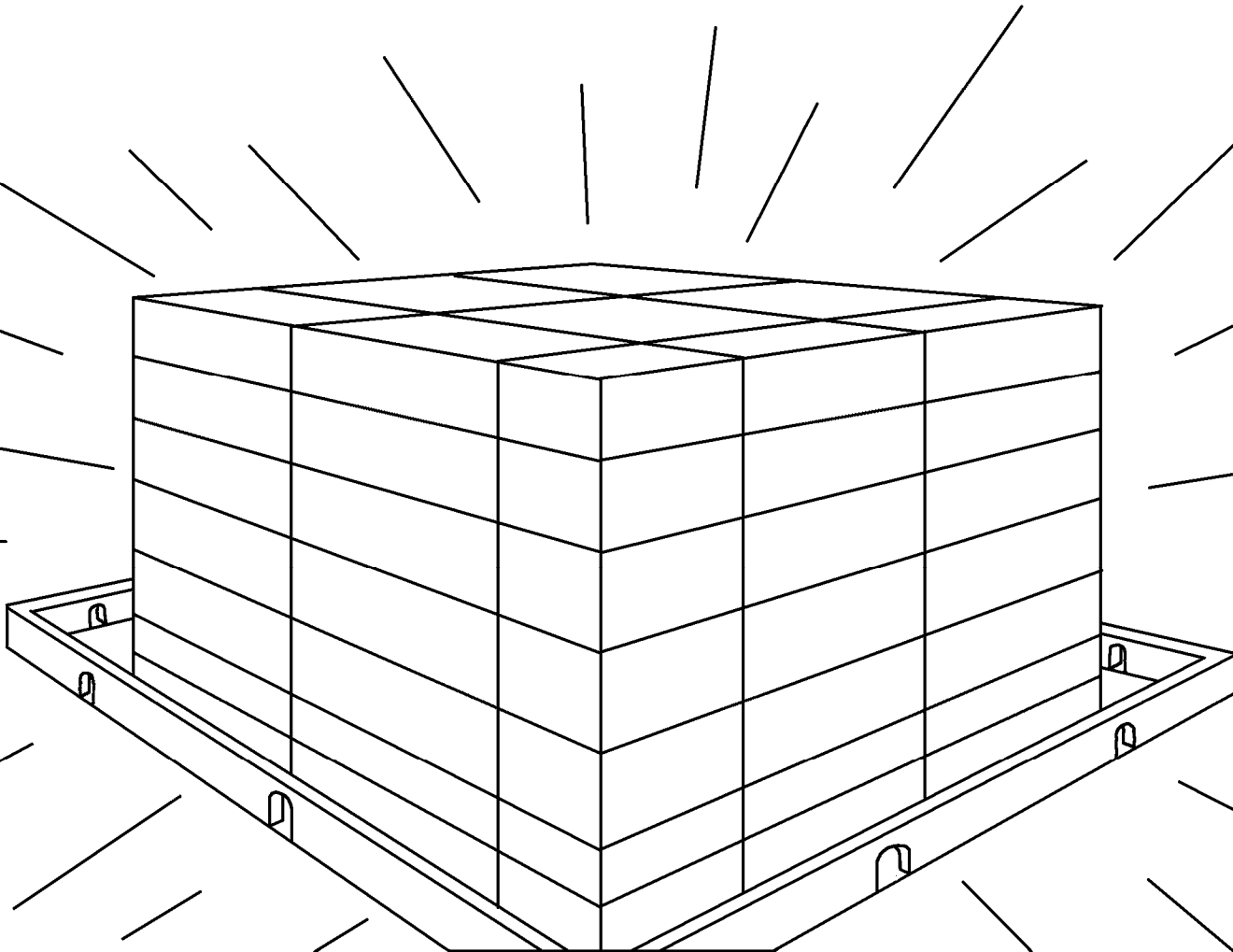

Ŋinigo tinayanun gogo sananinere tina buru buk
manjo qurangabi pega, yonjoji akon siti oo ropenimin.
Lama madeineji tina buru buk
oi sinan gaega. Moji manine
kejigaga me wuwunun
anjin mamagiineke eru
bujo ikoine miega,
injoji oo ropeinjo
embimbinjan. Onu.

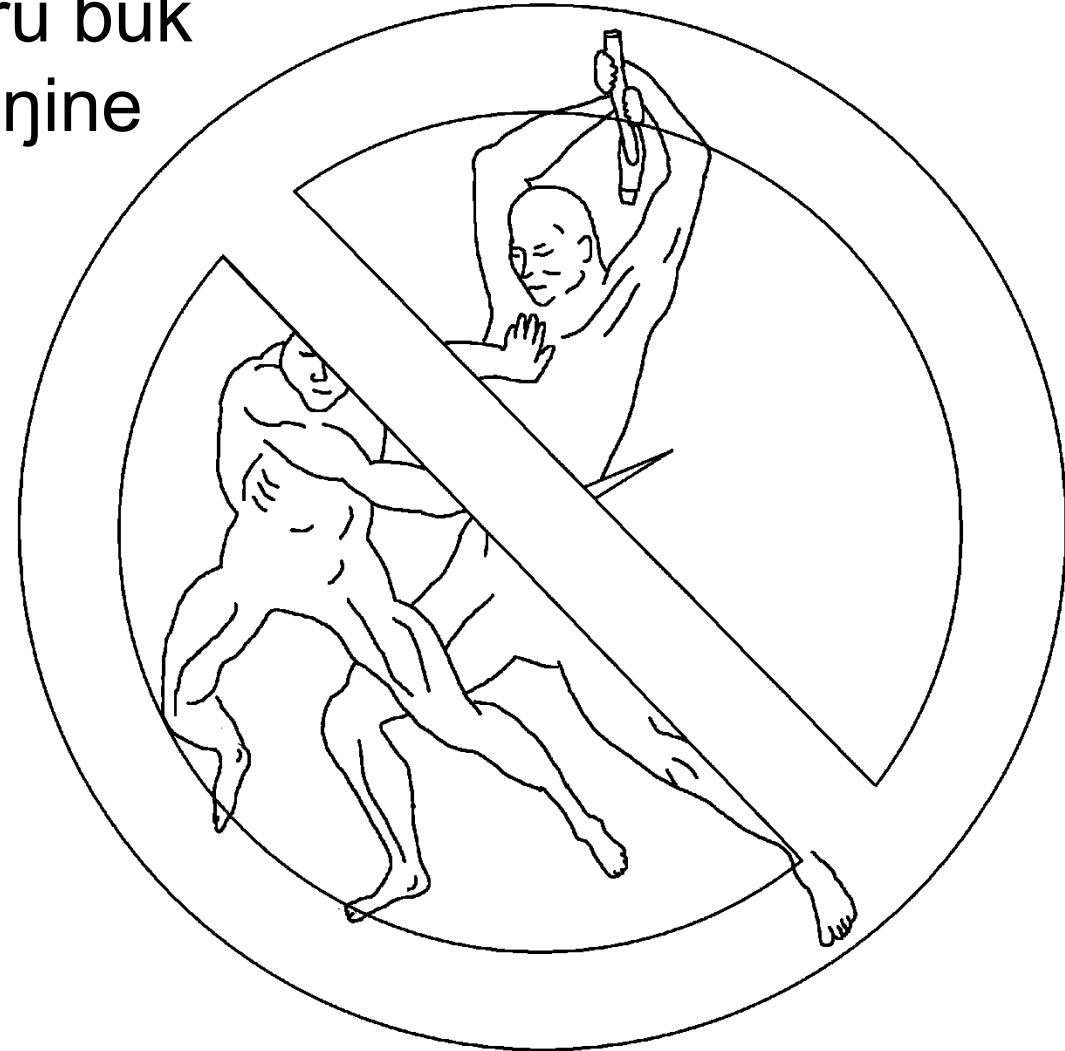

“Yonjoke goku jinjo obuyanun
sosowo ketaninga forein. Ya
sosowo rone peya, oiji matae
foreya. Ore eru moke so komebi
jingen so keniminu eru jikigaru
joisereren mo so maneniminu.
Ya more so embimbingaru
kuyoniminu.”



Moji mo so jikigaru ogoine sowegaru qaisogain. Anutu eru Lama madeine yokore morumboŋ ɲeɲeyakunji oi siti oo peko Lama madeinere gio bobo ɲiɲigopuji kiɲaŋ qa teegobi. Kiɲaŋ qa teru jiɲo maiine ɲoneru Anuture tina maiyaɲuŋgo bakatobi peiɲ.



Ra tomirebire njiggo komiine ropekiine eru
wakiqoqoine njone yabebe morumboŋ njene manfunjo
dimabi Anutuji buk papiaine papiaine qoromureya.
Papia ogoine mo tinaine gogo sanaŋinere tina buru
buk oi oŋuakoŋ qoromureya.

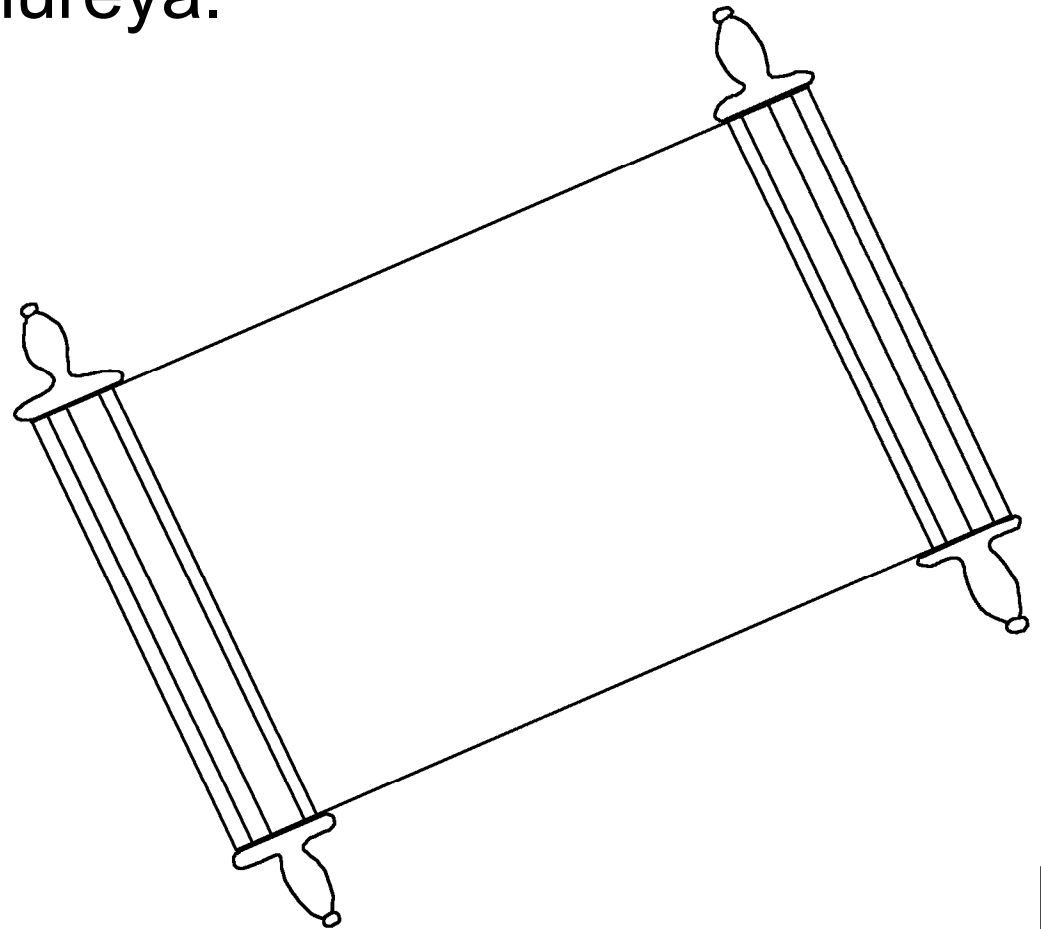

Qoromureru njigigo komiine yonjore buŋo osoeko
eeboboyaŋunde binaŋ buk papiago quraŋgabi pega,
iŋoji ore so oseru njigigo mitari yareya. Anutuji more
tina gogo sanaŋinere tina buru buk maŋgo so
quraŋgabi peko bofukeya, oi igogako
yon misi boruŋ jaku wenjwen
qaku dimaega, ore
korugo rakaya. Onu.

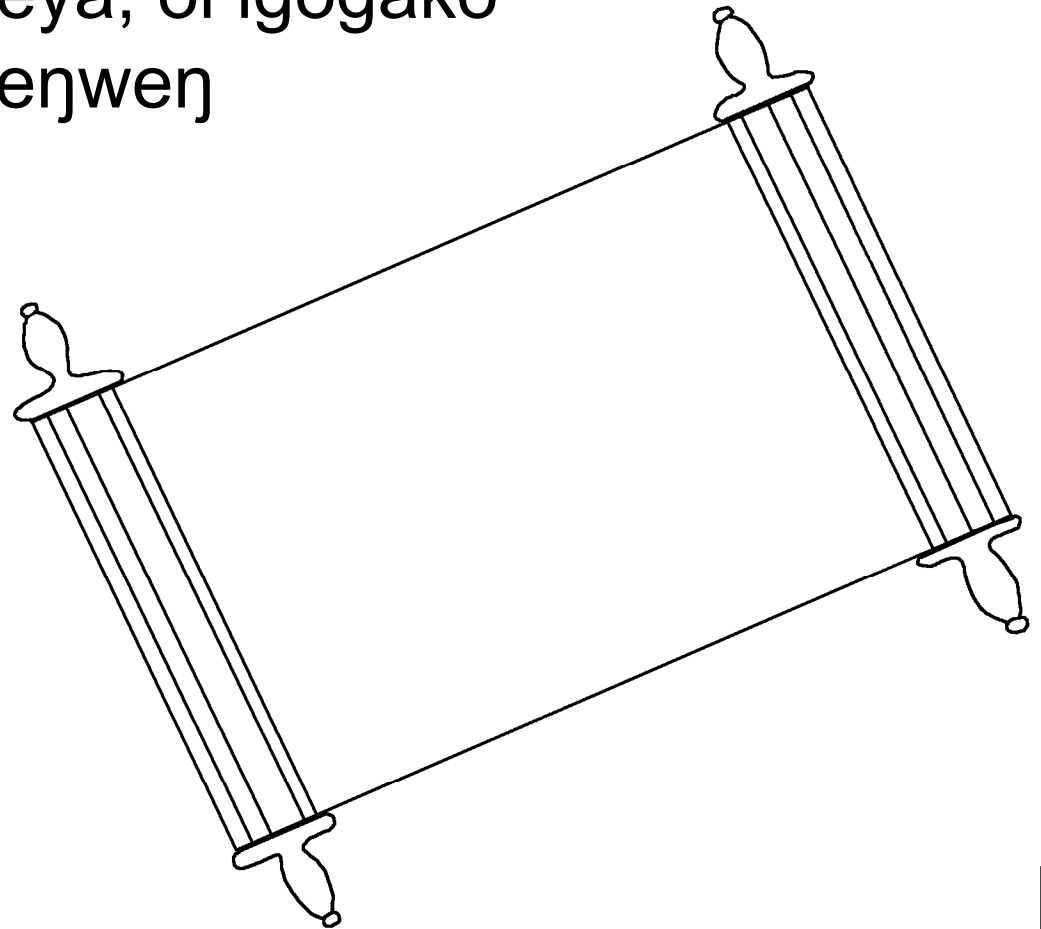

Moro Tiriine eru njigo binje yokoji inji miegobire, “Yesu, go bio ware.” Onu mibire maneniminj, njono onuakon inji miinebi, “Yesu, go bio ware.” Moji obure manega, inoji warenonj. Moji gogo sanañinere obure anj manega, inoji wareru oi yaun roru sabareine. Onu.



Ore funjine oi inji: Ŋinjigo oi manesiŋ
gaegobi, yoŋoreone moji egu sibirigainggo
eru Anutuji moreŋ so jeŋgoma manjoko
enoreya. Noŋuŋ sosowo qowirieru
gogo sananjinere biŋe fukekiminŋ
ore eru Madeine moakonŋ
yobu oi noreya.



Rom 3:23

Ŋinigo sosowo nonun agiburan eku Anuture kuririqurande eru embimbinḡagobeneḡ.

Rom 6:23

Agiburan ebeneḡ Rauineji furi noreko kome sananeḡ bofukekiminḡon, Anuture yaun oi seḡḡinḡanḡinḡ gogo. Kristo Yesu Ofoḡnonḡunḡe qakatoru dimakiminḡ ine, sananḡaru tatariine tomiri go ropekiminḡ. Onu.

Hibru 9:27

Moreḡ ḡinigo nonunde buru oi inḡ pega: Nonunḡ damanḡ mogo komekiminḡ eru ore ḡadio Anutuji buḡnonḡunḡ osoeru mitari noreinḡ.



Efesus 2:8,9

Anutu manesiŋ gabi yaunmoririineji munan qa nareme moke qowiriebuŋ. Ŋoŋo-ŋaŋe maŋgo ee eku oŋuine oiji so qowiriebuŋyoŋ, Anutuji yaunjinere eru qowirie nabeŋa. Ŋoŋo-ŋaŋe ya mo basarigabuŋ ore eru so qowiriebuŋ. Moji mo iŋoyoŋunde saki egu ba ropeiŋ ore eru yaunmoririinere akoŋ oŋu eŋareŋa.

Rom 10:9,10

Anutuji Yesu bogboreme komegone pakereŋa. Goji buŋo oi maŋ wombunŋgoji manesiŋ garu mi bibigoji “Yesuji Ofonŋe fukega,” oŋu mifukege ine, iŋo munan qa gareko qowiriemiŋ. Go maŋ wombunŋgoji Biŋe buŋo manesiŋ gande Anutuji buŋogo mitarime posikemiŋ eru mi bibigoji Yesu mifukende munan qa gareko qowiriemiŋ.



Jon 3:16,17

“Ore funjine oi inji: Ŋinjigo oi manesiŋ gaegobi, yoŋoreone moji egu sibirigainggo eru Anutuji moreŋ so jengoma manjoko enoreya. Noŋuŋ sosowo qowirieru gogo sananjinere biŋe fukekimiŋ ore eru Madeine moakoŋ yobu oi noreya. Ŋinjigo moreŋ so go ragobeneŋ, Anutuji Madeine noŋunde buŋo mitariinggo ore matayoŋ, Madeineji munan qa noreko kantri so qowirieru seŋgiŋbaŋgiŋ fukekimiŋ ore eru soreme moreŋgo wakiya.



1 Jon 5:11-13

Anutuji bunjoine inji kitingaku miya, “Nonji gogo sananjine nareinj ore mibe, nake Madeneji gogo sananjine ore kukure Rauine fukega.” Injore Madeke qakatoru goga, injoji gogo sananjine raugaru goga. Anutu Madeineke so qakatoru goga, injoji gogo sananjine so raugaru goga. Onu. Manj-nanjunj kerisieru Anutu Madeinere tina oi manesinj gaegobi, nonji quranj yo njonjore quranjago. Gogo sananjinere binje fukegobi, njonjoi ore funjine poretinj mane mukuniminj ore eru yo quranjago.



Jon 14; 2 Korint 5; Bararinj 4, 21, 22

Storyline by: Edward D. Hughes

Illustrated by: Lazarus
and Alastair Paterson

Adapted by: Sarah S.

Mape NT (mlh) © 2014, Wycliffe Bible Translators, Inc.
All rights reserved.

<https://live.bible.is/bible/MLHPNG/MAT/1>

©2026 Bible for Children, Inc.

www.M1914.org

www.bibleforchildren.org

