

www.BibleForChildren.org



Johani 14



Yesu ngou a wa amberire ci: "Mwa cithzekera mu micima thzenu. Mu tawe kwa Nyambi no ku tawa noku ku kwange kengeyo. Mu nthzio thza Tata mo tu di tupingwethzi totungi."



“Nga kadi kengeyo ne, ine nga ni na mi amberera ci naa thza ni ka mi roithsere ndau? Ou na ku thza no ku ka mi roithsera ndau, kenge na ku ka huka ku na mi shimba ci mu kekare nange oku ni di.”



Yame no Johani, mwapenu mu thsitawo, karo
muenthzeno mu makando no mu Kutumina kwa
Nyambi no mu kucitanarithsa oku a

twithsera Yesu. Shime
nekarire muya mu diongo



di nethsiwa Patimosi
mukaci ko ku amba
diywi dya Nyambi
nombangi wa Yesu.



Popo nekarire mu Mupepo wa Nyambi, ngou na monine ngunja mu wiru apa kwekarire munu.

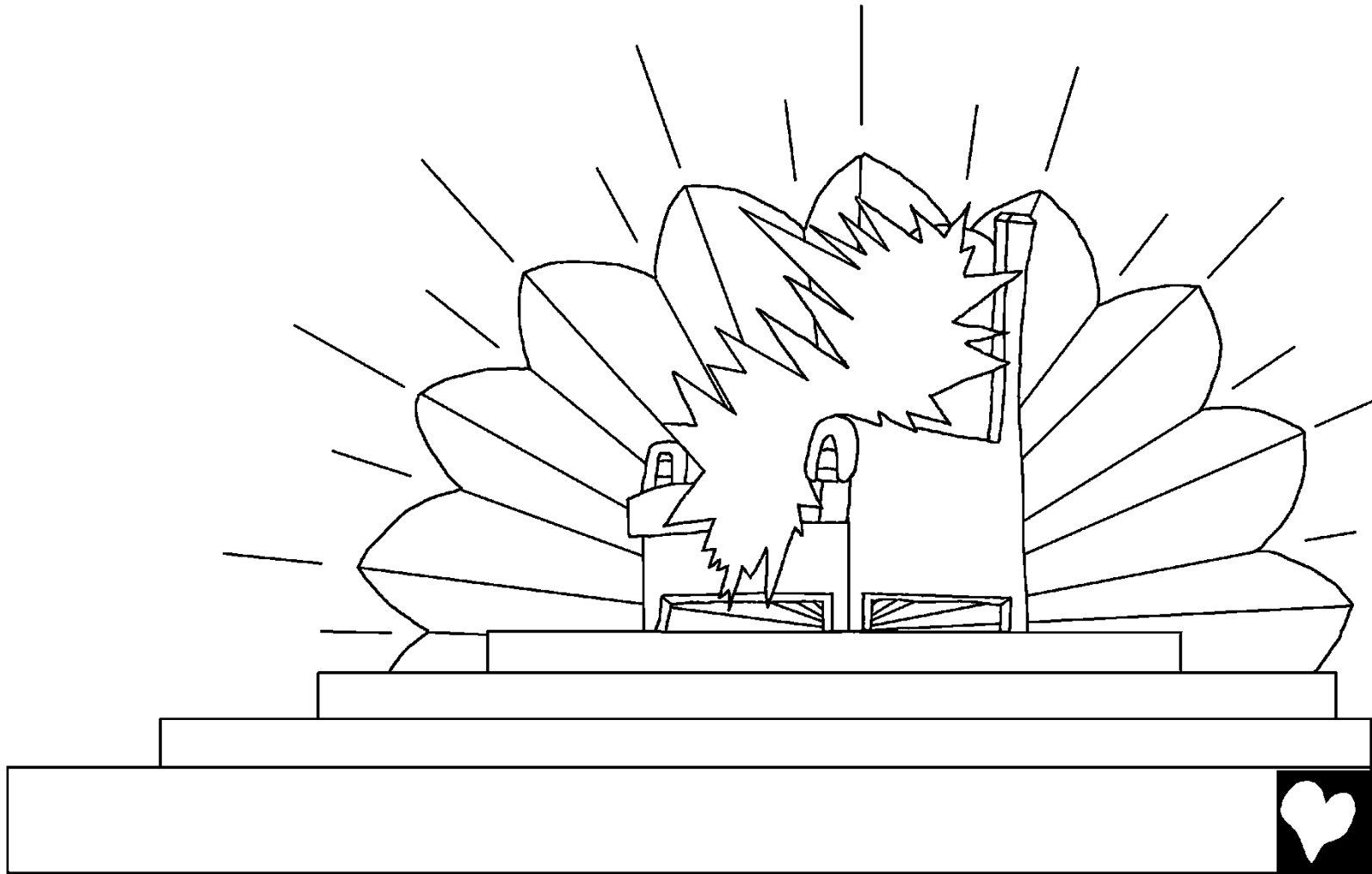

Ngou na yuvire yumbiwa yoihe eyi i di mu diwuru, eyi i di mu kaye, eyi i di kushi thzo kaye, neyi i di mu diwate o ku i amba ci: "Koyu di pa ngunja, noku kwa Dinguana, kwikare kushangariwa, direma, kutethzima, nokoro diyere na diyere!"

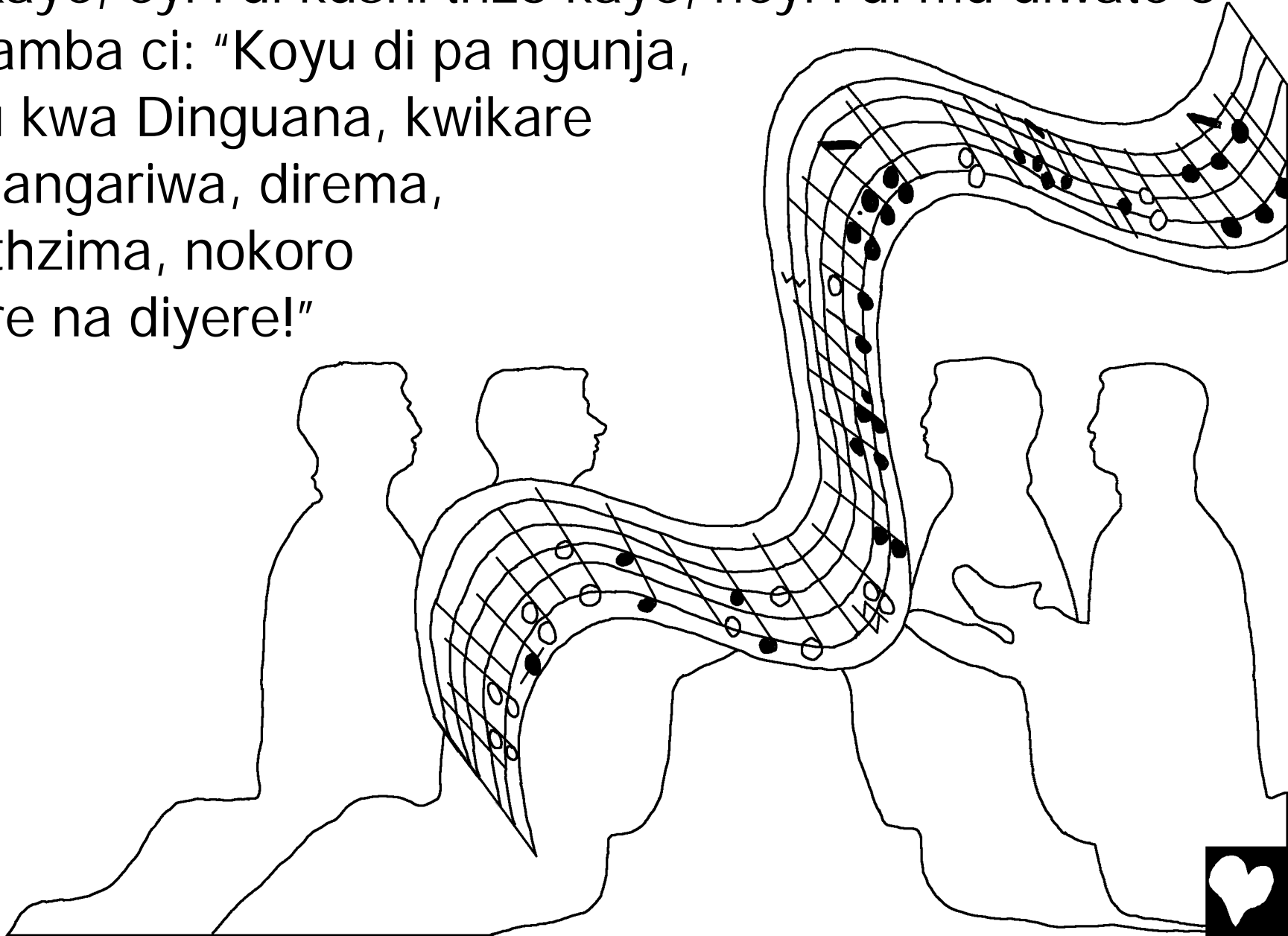

Na monine Thsikuña Thsoshokenu, aye Yerusalema omupe, o ku shurumuka ku tunda mu wiru kwa Nyambi, o ku na roithsiwa nawa no ku yengiwerwa munuwenthzi eci mwenga. Na yuvire diywi dyodikuru ku tunderera ku ngunja ci: "O mone, ndau omu a tunga Nyambi mu kaci

kanuenthzi thzi di honi, karo kenge a ku yoyano. Kenge a kwikarano, karo kenge a kwikara anuenthzi, karo aye Nyambi kenge a kwikara Nyambi wo."

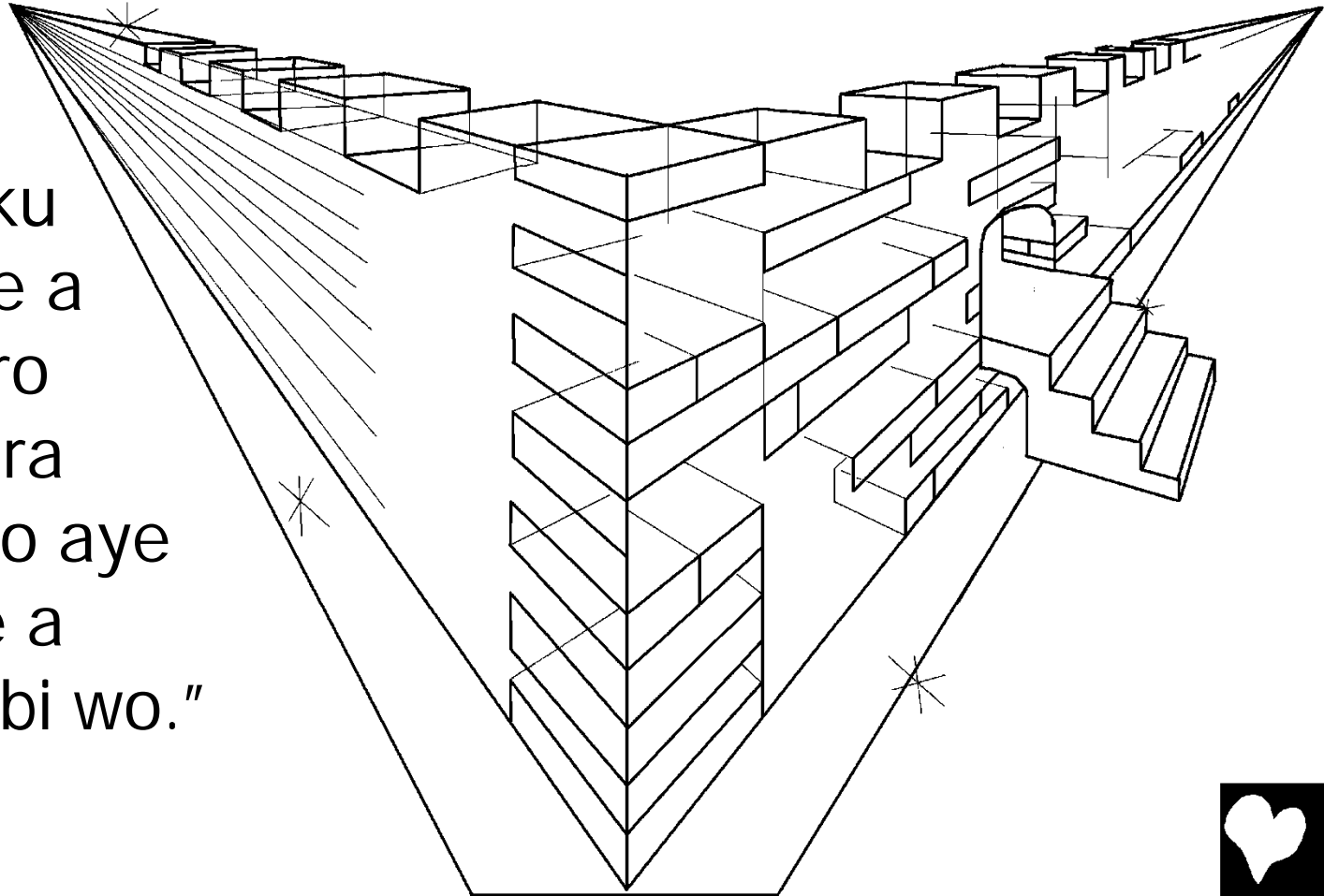

Kangeru ngou ka ni monithsire aro rware ro meyu o mwoyo. Rwa tethzimine tethzi eci kirisitale, o ku ru pupa ku tunda ku ngunja thza Nyambi nethzi thza Dinguana.

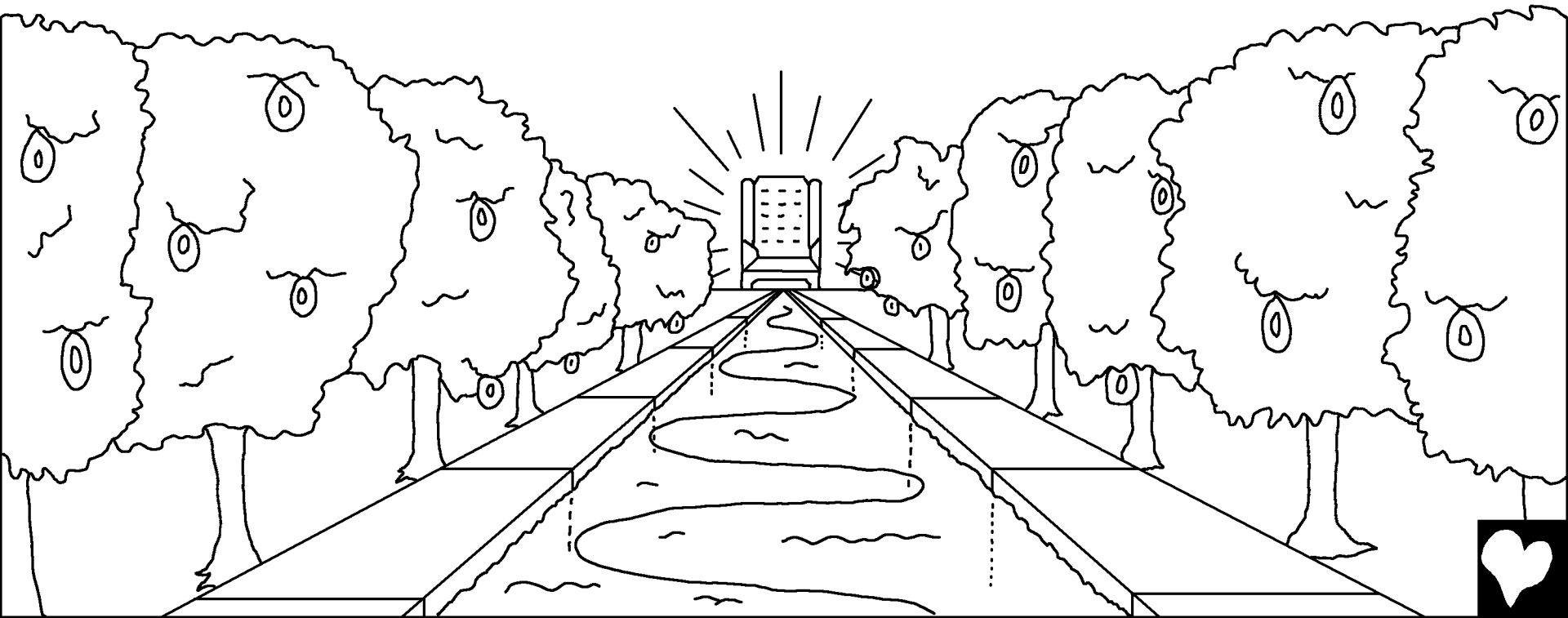

Ethso thsikuña ka kwa fotaharire ci shime kwikare diyuwa nji ngonda ku thsi munekera, inene kutethzima kwa Nyambi kwa thsi pire mwethzi, karo Dinguana yodiyo kambarambara kathso.

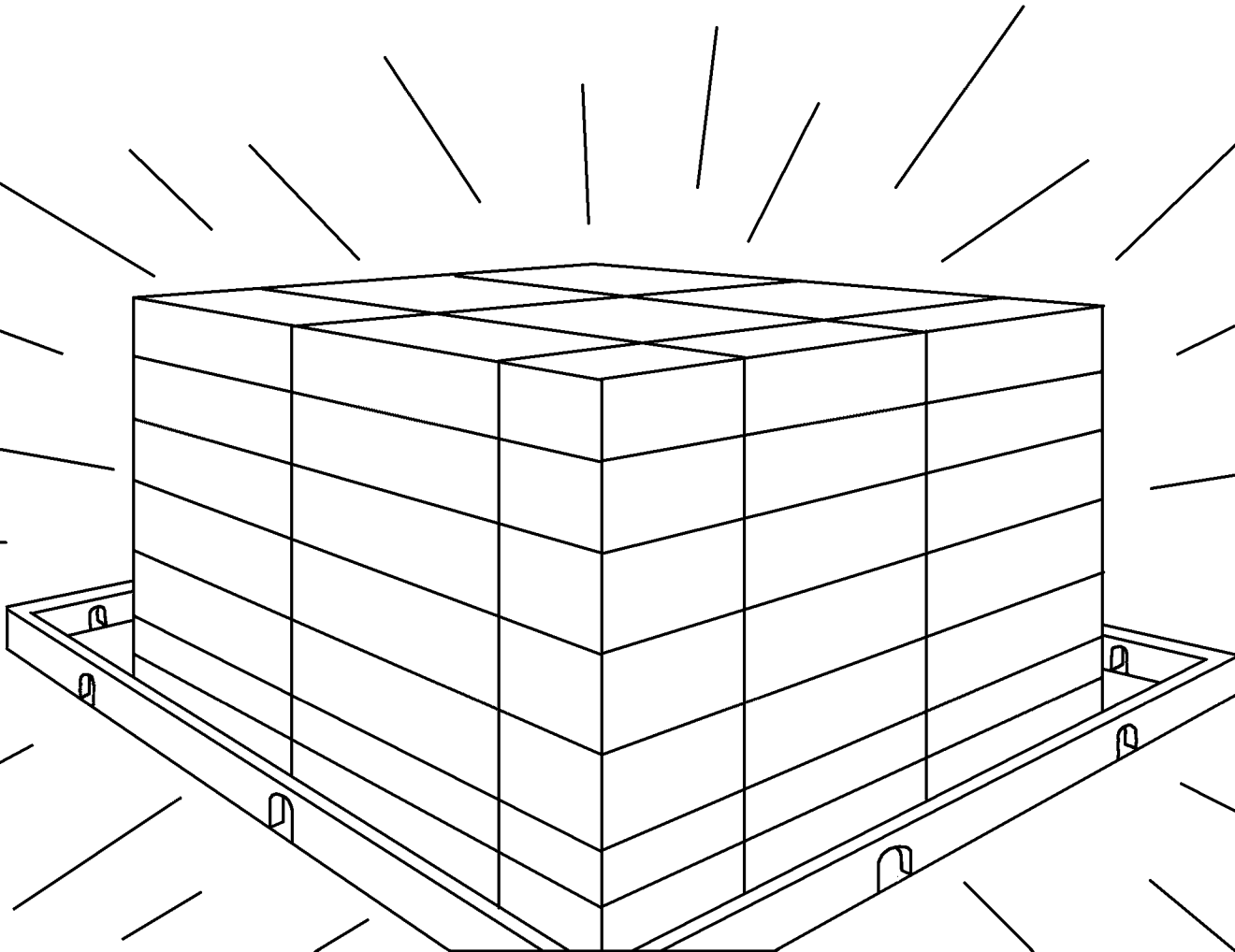

Kwithsa thso dithziro ethsi mba
thsingenamo omo mu thsikuña, nji munu
oyu na a kwama omango o
kupiterera nji kwangera.
Kenge mba kwingena
pohuma awa ñoriwa
mu Vuka thzo Mwoyo
thza Dinguana.

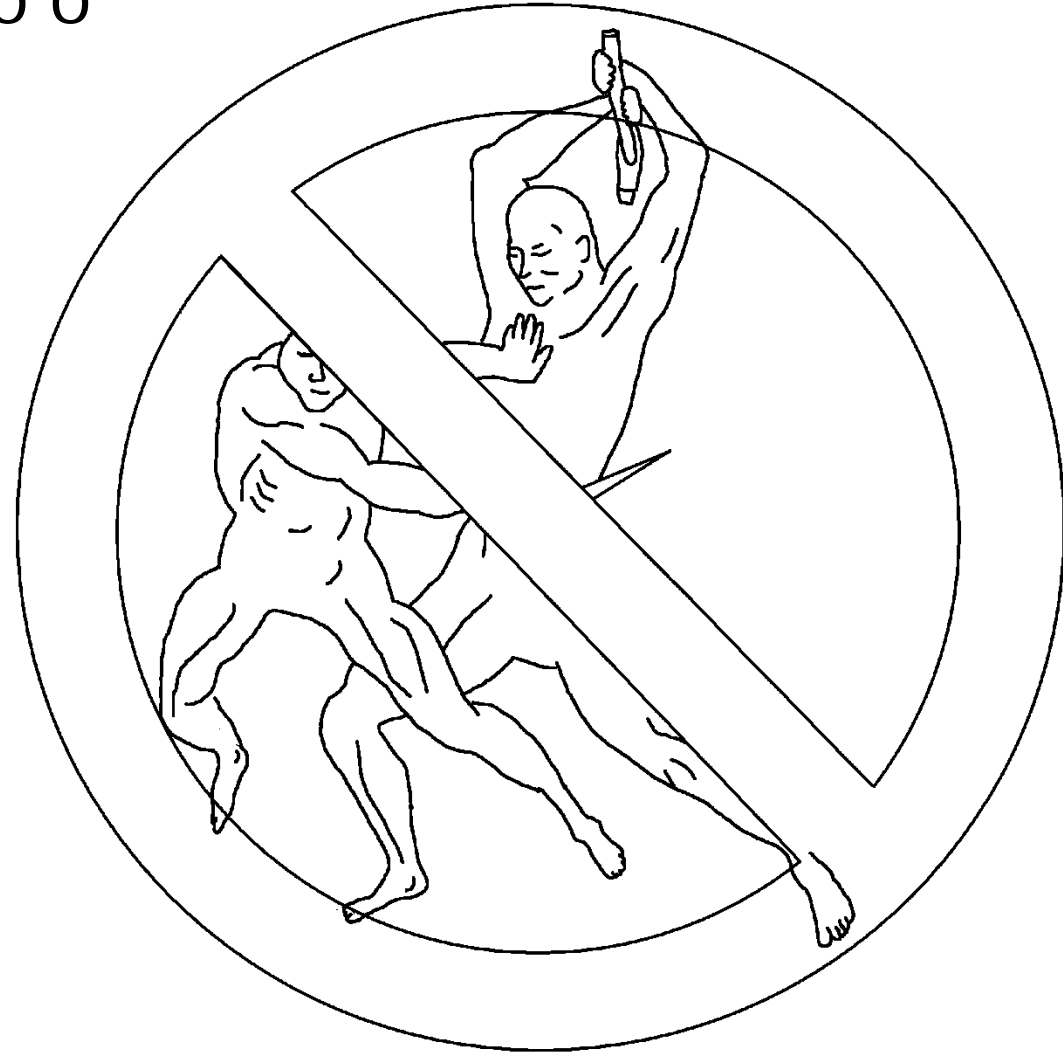

“Kenge a ku porora mihothzi thzothzihe
ku meho o. Ka kwa kwikara kufa nji
thsidiro nji kudira nji kukora, inene enu
yo kare i na pu.”



Mbera ka mwikara thso ku kutiwa, unone ngunja thza Nyambi nethzi thza Dinguana kenge ya kwikaramo, apikenthzi kenge mba mu kwamena. Kenge mba mona rupara rwenthzi, kenge mba ñoriwa dithzina dyenthzi pa rupara.



Ngou na monine afu, owakuru nowa owaonye o kwa nemana pa rupara ro ngunja thza Nyambi. Mavuka a thsikuriwire. Ngou kwa thsikuriwire vuka thzimweya, athzo Vuka thzo Mwoyo. Afu a raturiwire kokuthza keyi ya ñoriwire mu mavuka, eyi a kwamine. Yomuhe oyu wa waniwire ci ka a ñoriwire mu vuka thzo mwoyo wa kuheriwire mu diviya dyo mudiro.

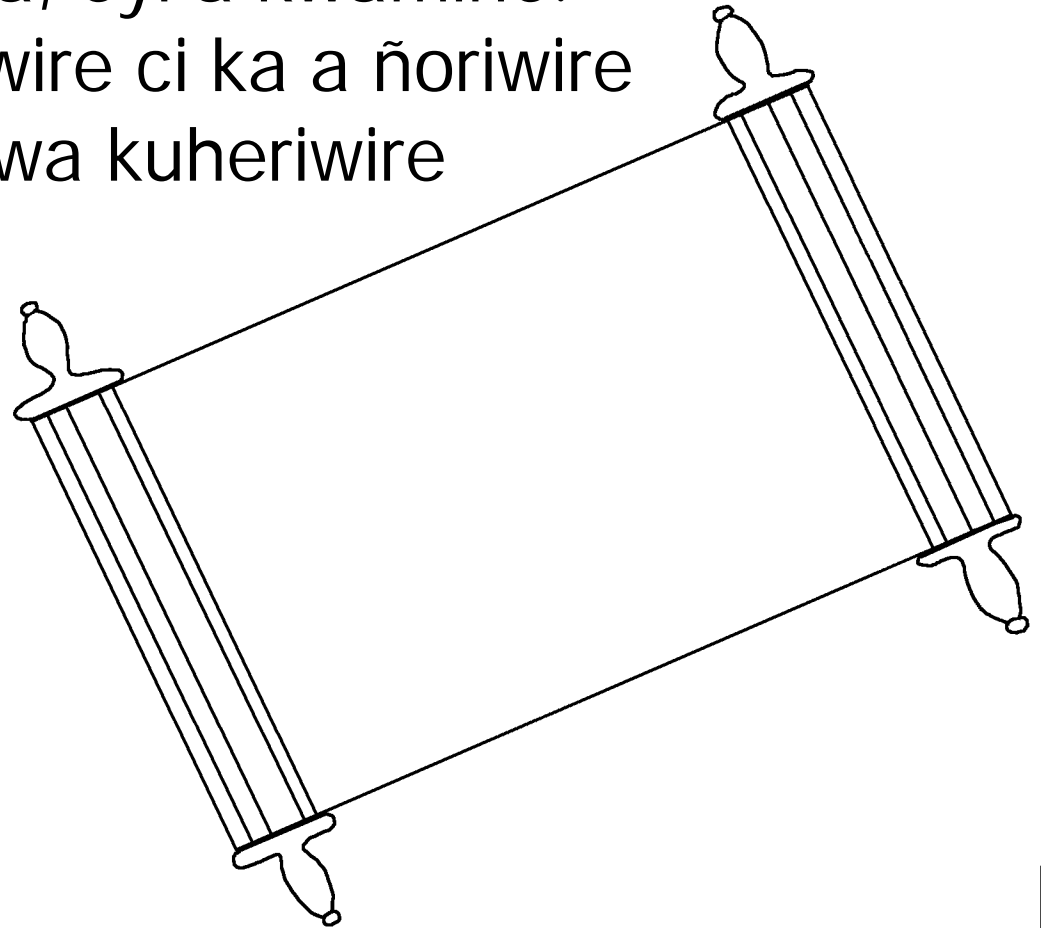

Mupepo na mwenga aa amba ci: "O keye!" Oyu na yuvu eyo yomuhe naye a ambe ci: "O keye!" Yomuhe oyu na fu dinotwa a keye, yomuhe oyu na shimi a nwe ku meyu o mwoyo ko kupira ku patara.

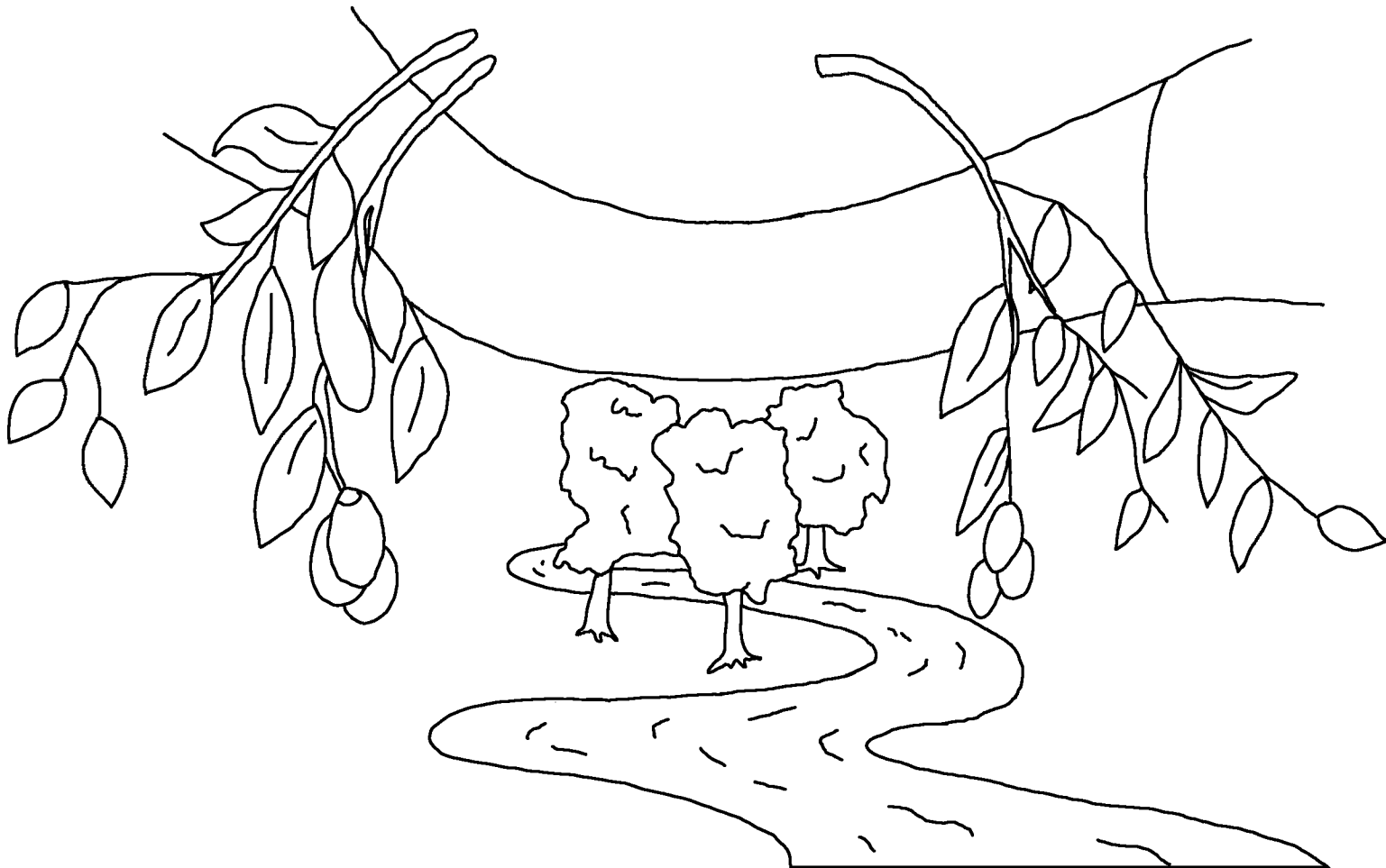

Inene Nyambi wa shimine nene kaye
ku ninga ci mane wa ka pire Mwane
yofoci pakamutwa ci munu yomuhe o
ku tawa ku kwenthzi a ku nonga,
unone a ku wane mwoyo o
diyere.



AkwaRoma 3:23 inene anu wahe na tende thsivi, mweyo, wahe na kwanga ku kuma ku kutethzima kwa Nyambi.

AkwaRoma 6:23 Inene muyambo o thsivi po kufa, unone thsipa thso kengekenge thso thsihemo thsa Nyambi po mwoyo o diyere mwa Krisitu Yesu Fumu wetu.

Maheveru 9:27 Eci dyodi a na roera munu yomuhe ku fa muendo ofoci, munyima no ku mu ratura Nyambi,

AkwaEfese 2:8,9 Inene na mu yoyithsiwa ko thsihemo thsa Nyambi ko thsitawo. Oko kuyoyithsiwa kadi cingwa kwaa tunda ku kwenu, unone thsipa thsa Nyambi.

Kuyoyithsiwa po kadi cingwa kwaa tunda pekwama, mweyo, kwithsa oyu nga ku cishangarera.



AkwaRoma 10:9,10 Inene ngeci owepo citawera ko kanwa koe ci Yesu po Fumu, no ku tawa mu mucima woe ci Nyambi wa mu pindurire kwafu, kenge wa ku yoyithsiwa. Inene ko mucima munu aa tawa no ku tendiwa omuwawa, karo ko kanwa munu aa citawera no ku yoyithsiwa.

Johani 3:16,17 "Inene Nyambi wa shimine nene kaye ku ninga ci mane wa ka pire Mwane yofoci pakamutwa ci munu yomuhe o ku tawa ku kwenthzi a ku nonga, unone a ku wane mwoyo o diyere. Inene Nyambi kadi cingwa shime a tumine Mwane mu kaye ku na ka ratura, unone ci kaye nga ka yoyithsiwe kenthzi."



1 Johani 5:11-13 Ou odiyo ombangi ci Nyambi na a tu pa mwoyo o diyere, karo ou mwoyo po mwa Mwane u di. Oyu di na Mwana, o di no mwoyo; yomuhe oyu na piri Mwana Nyambi, ka a di no mwoyo. Naa mi ñorera eyi amwe mu na tawa mu dithzina dya Mwana Nyambi, ci nga mu dimuke ci mu di no mwoyo o diyere.



Johani 14; 2 Akwakorinte 5; Ehokora 4, 21, 22

Storyline by: Edward D. Hughes

Illustrated by: Lazarus
and Alastair Paterson

Adapted by: Sarah S.

Mashi (NT (mho) ©2023 The Seed Company

<https://www.bible.com/bible/3749/MAT.1.MHO>

©2026 Bible for Children, Inc.

www.M1914.org

www.bibleforchildren.org

