

www.BibleForChildren.org

Jon 14

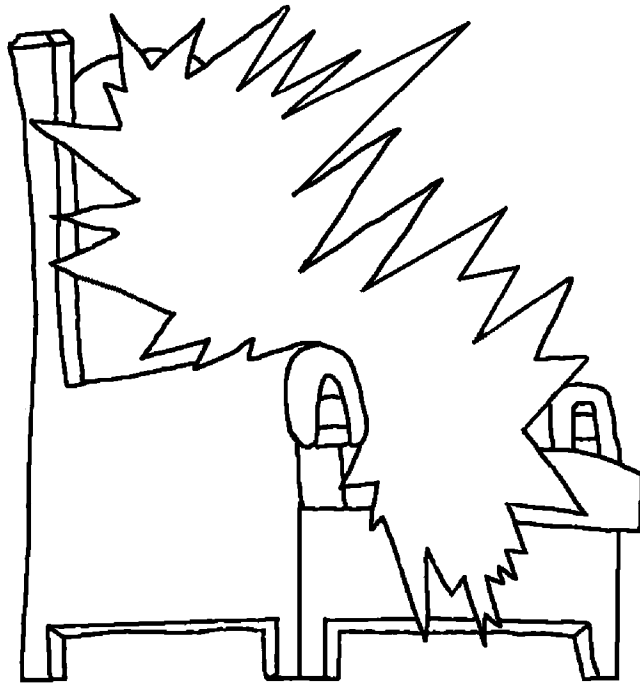

Jesudi mihiniye indin yeninguk, “Hidi bulaningon tinja nadibedi mu tinen. Bepan nadisukilitimiņa nu maan nadisukilitinamnen. Nu Batne yolineņ yotmaan fee hakiņ ala nu woon hiditok kwet tiulidokohambaat. U mu hatuwek binek adi mu hanilit.”



“Ale nu woonj kwethik tiulidokoonj kotigonj udaneenj bunja hanagila woonj na hatibaatnenj ungonj nonjonj hatineem.”



Nu nohik Jon. Indi Bepañ'walañ hatihati ungoniñ
kahileenñ nonñonñ hatiyam, tiña Jesu'walañ
kayonbop doktiña mik-kwadi ginenñ

folofigita wanañ nadiñila
gigine tiña hatiyam.



Ingon on, nu Bepan'walaŋ mede, eŋ Jesu wou
yohautagut doktiŋa kwet kambangit Patmos
uŋon napmeune itougut.

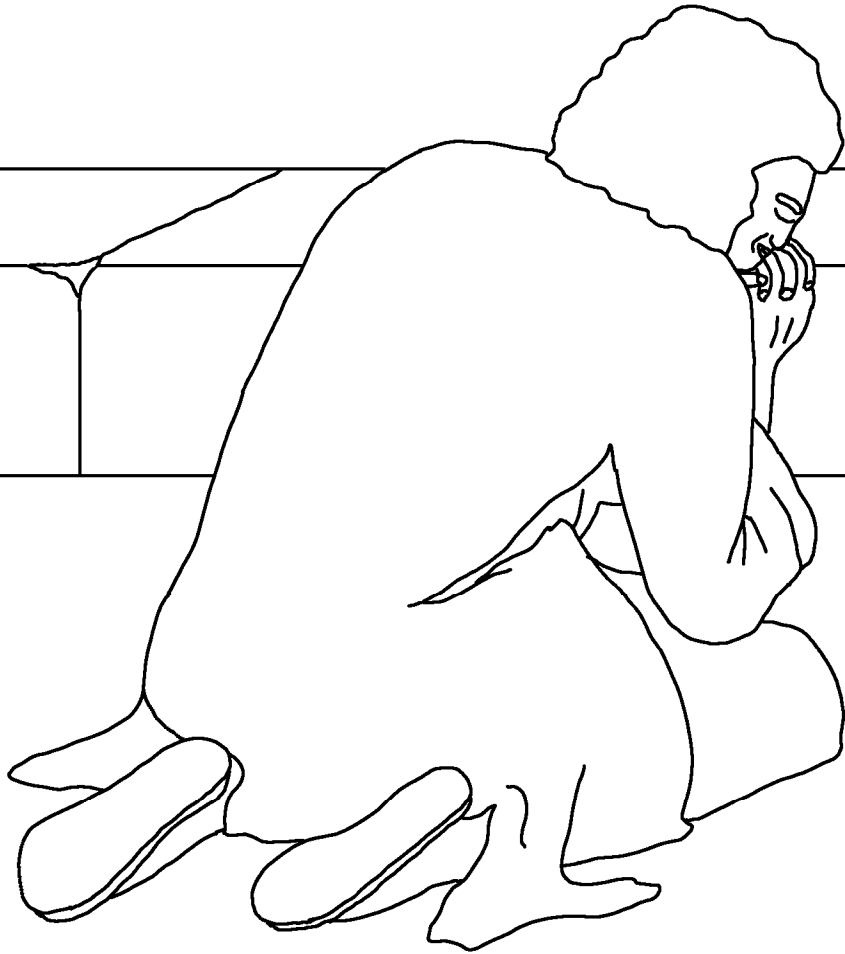

Unduŋ yobune uŋaniŋoŋ Uŋgoŋiŋ Munabulidi
saŋiniŋnit hinek fotokinambune kunum gineŋ mapme
pop niŋ ikuk, wendok gineŋ Me niŋ ilu kagut.



Kañ kunum ginen, be kwetfolon, be kwet falipmen, be imengwan ginen nemenemek hatitaugin hogohogok adi indin tobu nadigut. “Mapme pop ginen itak en Dompa Mihinin adi wanan yopilapilaye, en wohikgigit wapum, en wohikgigit hautanit, en saninin lolonit hayemilak wondigon fafanenin hayemiluwaak.”

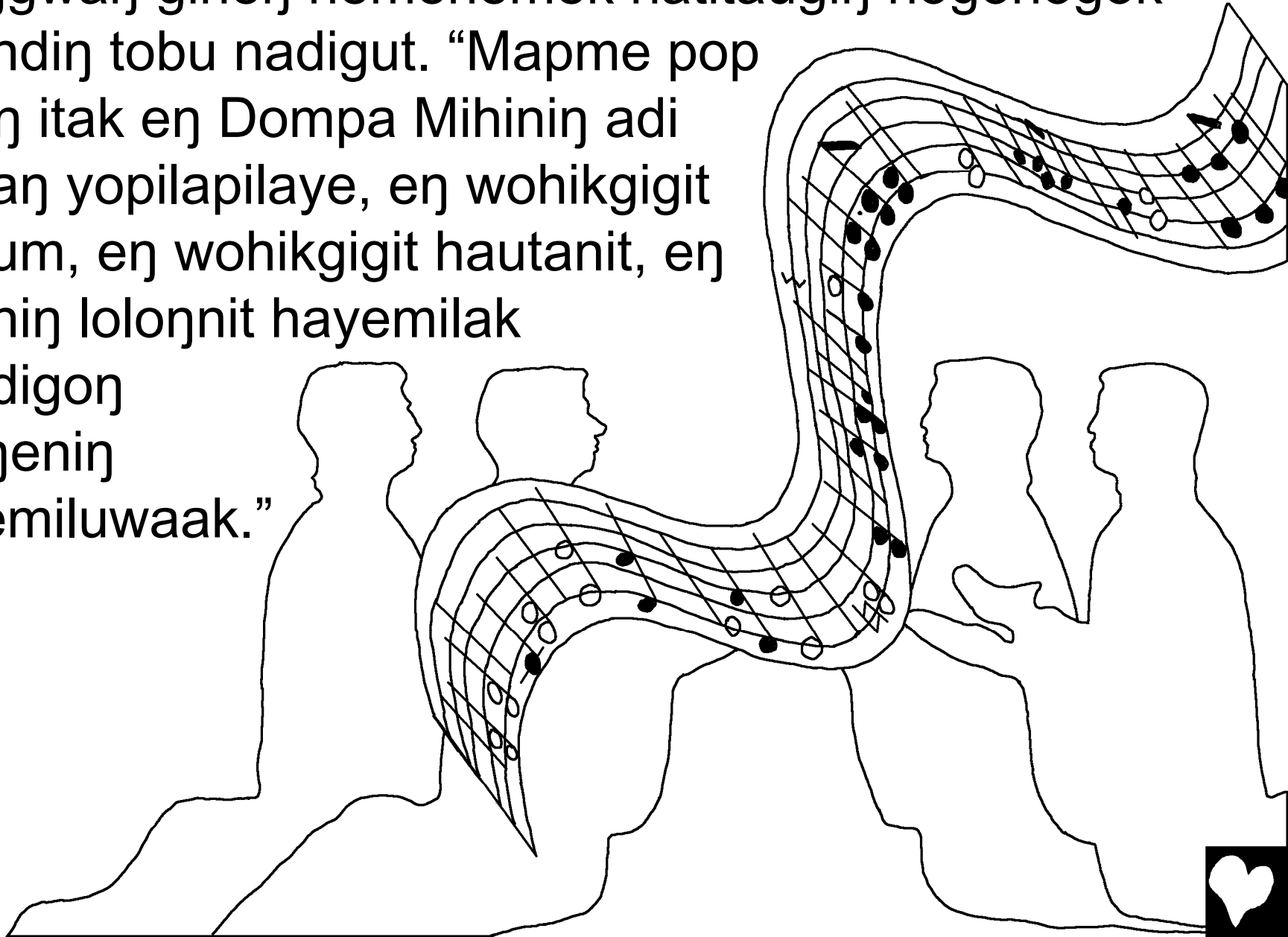

Kaŋ yokwet ungoniŋ, Jelusalem kobuli kuyon, kunum gineniŋ Bepaŋ'walaaniŋ founne kagut. Wabihem niŋ me dut yehikiutdok tinahukut tiyemiŋ unduŋ mohinek tutumbaŋ tinahukulimiŋiŋ kagut.

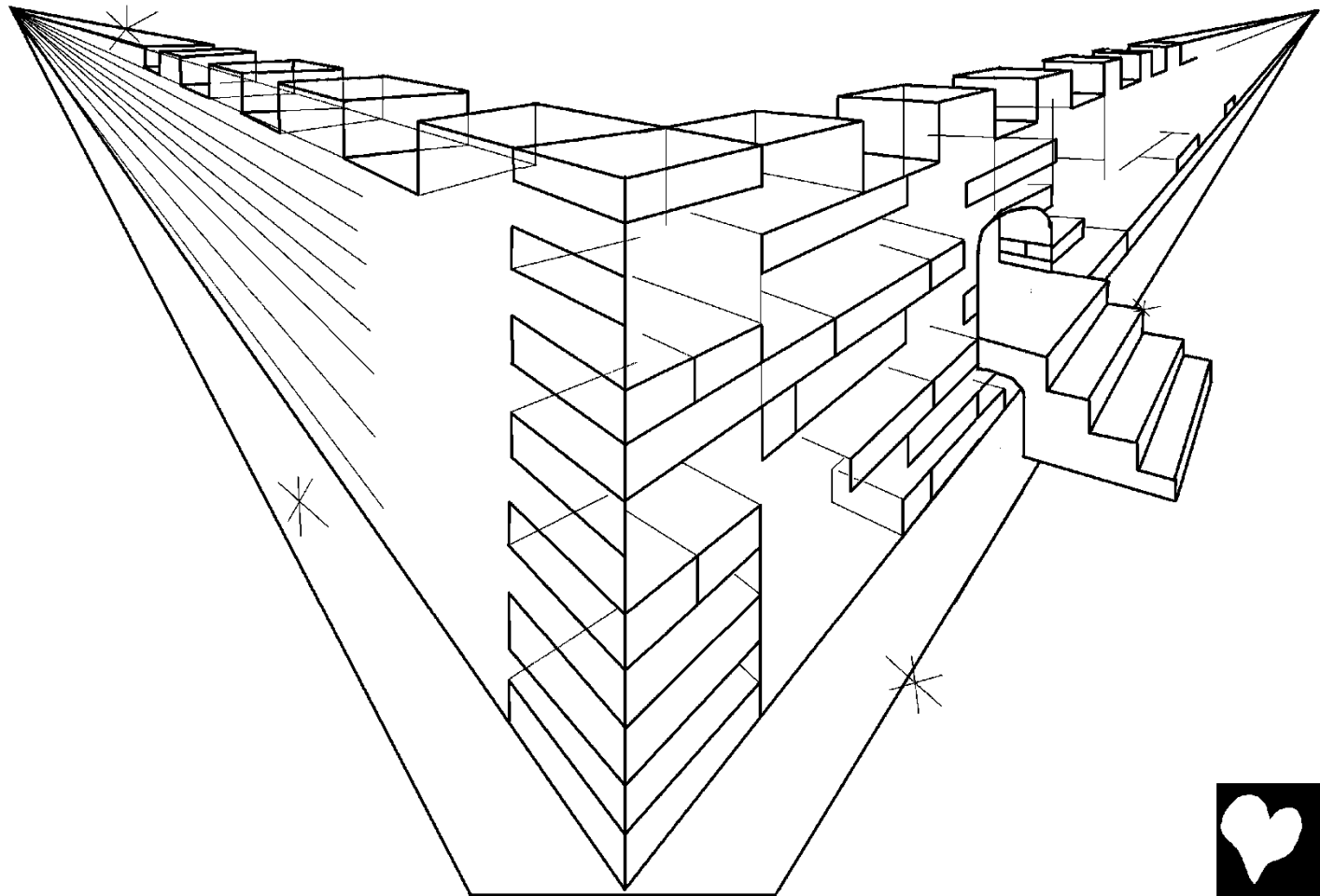

Kañ mapme pop ginenkade kutikuti wapum niñ indin
buune nadigut, “Biyagon hinek kuyon, u kalañ be.
Bepañ’walañ yolikweli agañ metam dut hatak.

Ne lekingonhik ginen
itoune

metamdi
adi’walañ

metamñiye tiña
itouneen. Bepañ

ne adut hatinila

dautilitikhik

tumolokudapmawaak.”

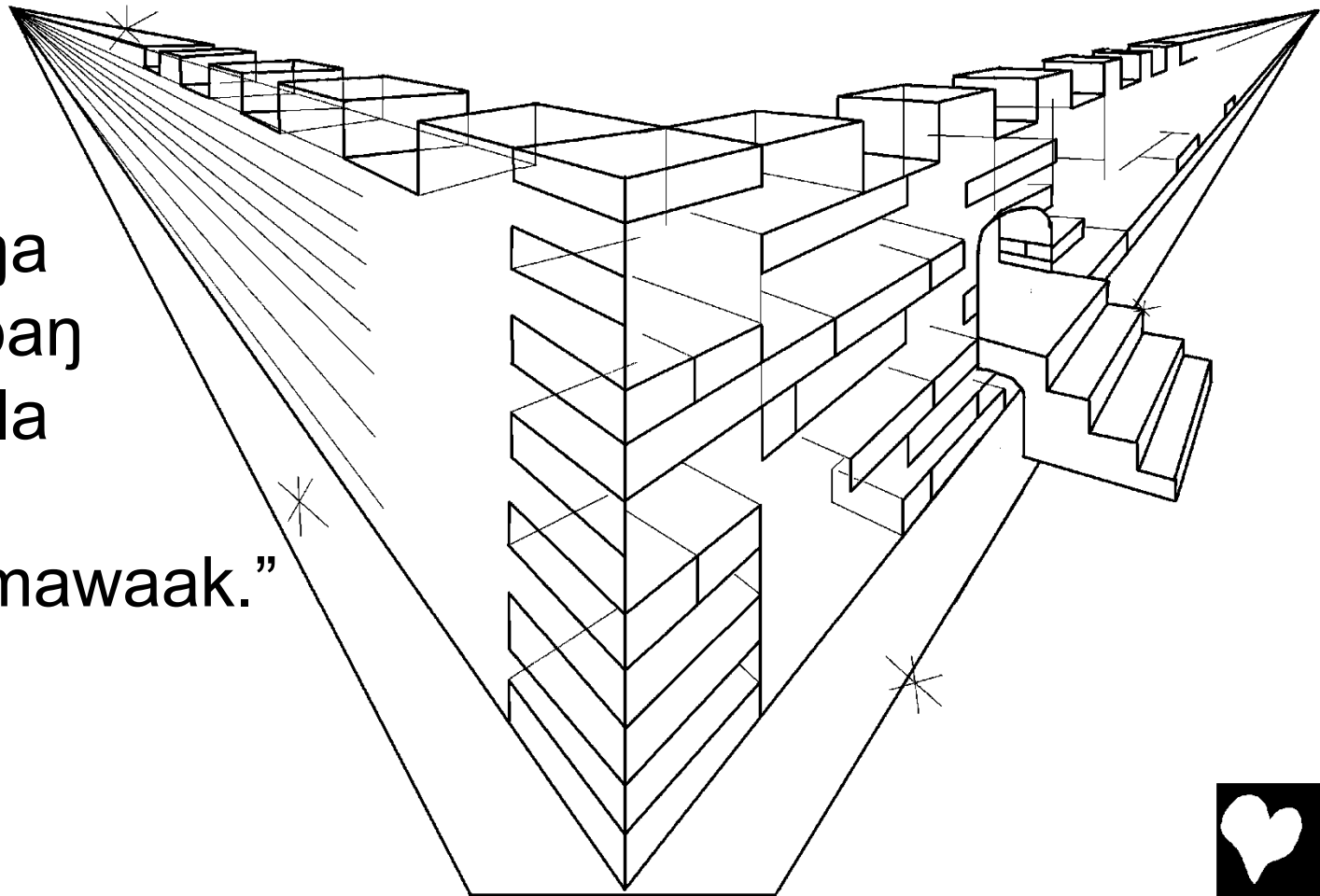

Anelodi ime wapum hatihatinit u titinenenambune kagut, wonj adi waliniņ hinek galas ginenj diwedapmanj tiyam undiniņ. Uyadi Bepanj eņ Dompā Mihiniņ adi'walaņ mapme pop mebineniņ bulak.



Tiņa yokwet uyadi muyakipbe, be meledi hauta mu yemilak. Bepaṅne'walaṅ hauta holiholiṅedi hautayemilak eṅ Domba Mihiniṅdi hautaṅiṅ tilak.



Enj nemek genjenit adi unonj mu hinek fowaak.
Be meeniñ niñ adi nemek mekaniñonj enj
madimadikenonj tibaak be
yalañ niñ kame hatibaak
adi maanñ yokwet unonj
mu yalikawaak. Wohiye
Dompá Mihiniñ'walañ
hatihati diniñ pepa
gineñ youlinjit adi
hogokdi yokwet u
kahileneeñ.

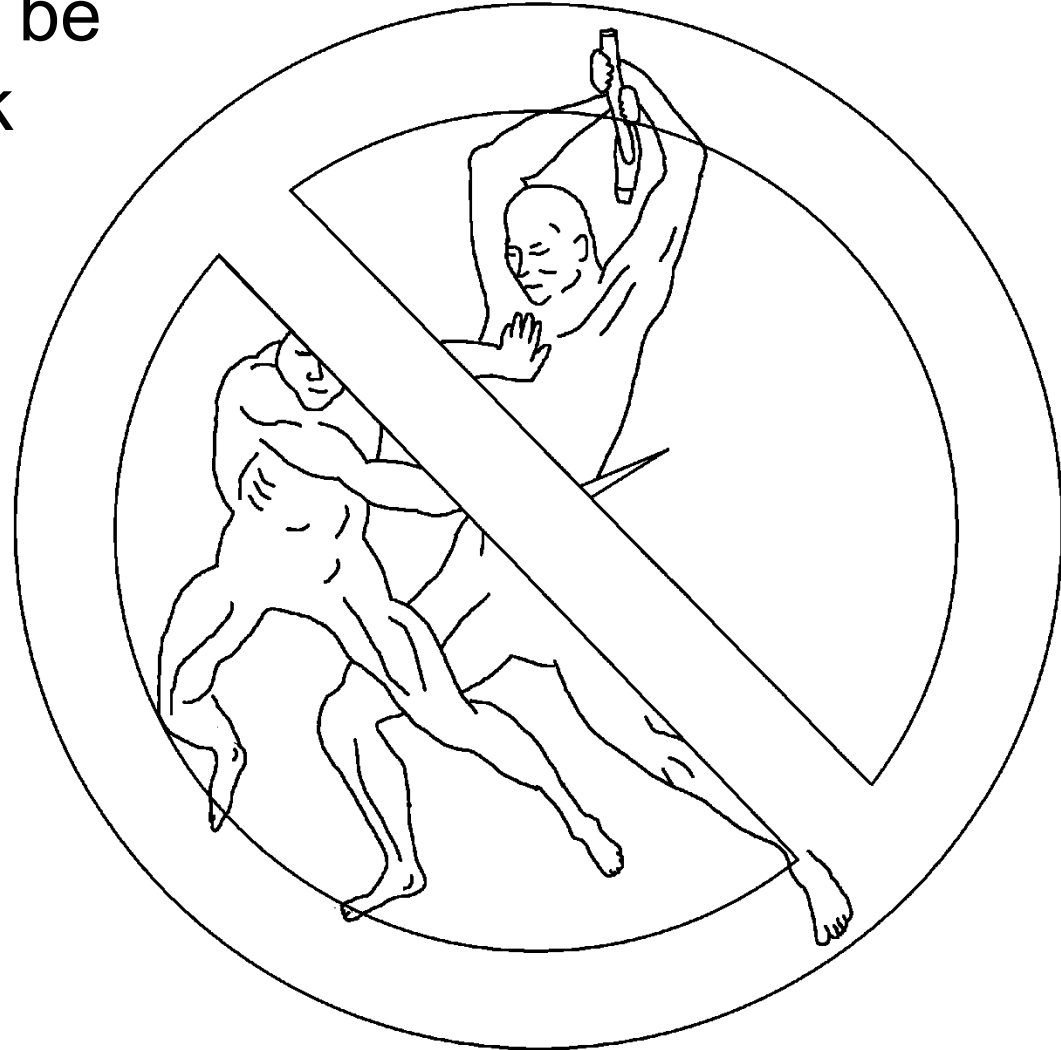

“Bepañ ne adut hatiñila dautilitikhik tumolokudapmawaak. Kumunñ be bulaniñgonñ be weyakawe be yagit folofigita unñonñ mu mintawaak. Biyagonñ kuyonñ, nemek komi hogohogok agañ unñaniñ dapmawaak.”



Yokwet unon adi nemek Bepandi yobune hakinit
tigin hogohogok adi unon mu hatneen. Bepan en
Dempa Mihinin'wala mapme pop unon hinek itune
metamjiye adi tipilapilaye kwanai hati timineen. Tina
undugon adi'wala
folonamandapnin
kanila hatineen, en
adi'wala wou
demehik folon
mintaan halaak.



Kaṅ kumuṅ tigiṅ, lolonit be fofonit adi wanakanṅ
hogohogok mapme pop hebenṅ folonṅ yalune yabugut.
Adi unṅonṅ yalune pepa mohok tanakiyeginṅ. Tiṅa niṅ
tanakiyeginṅ adi hatihati fafaṅeniṅ diniṅ pepa. Kaṅ
kumuhi adi yadi kaipmuṅ hatinila titinṅhik
tigiṅ wendiniṅ mede, pepa ginenṅ youlinṅit
u kaṅila medehik yodapmaginṅ.

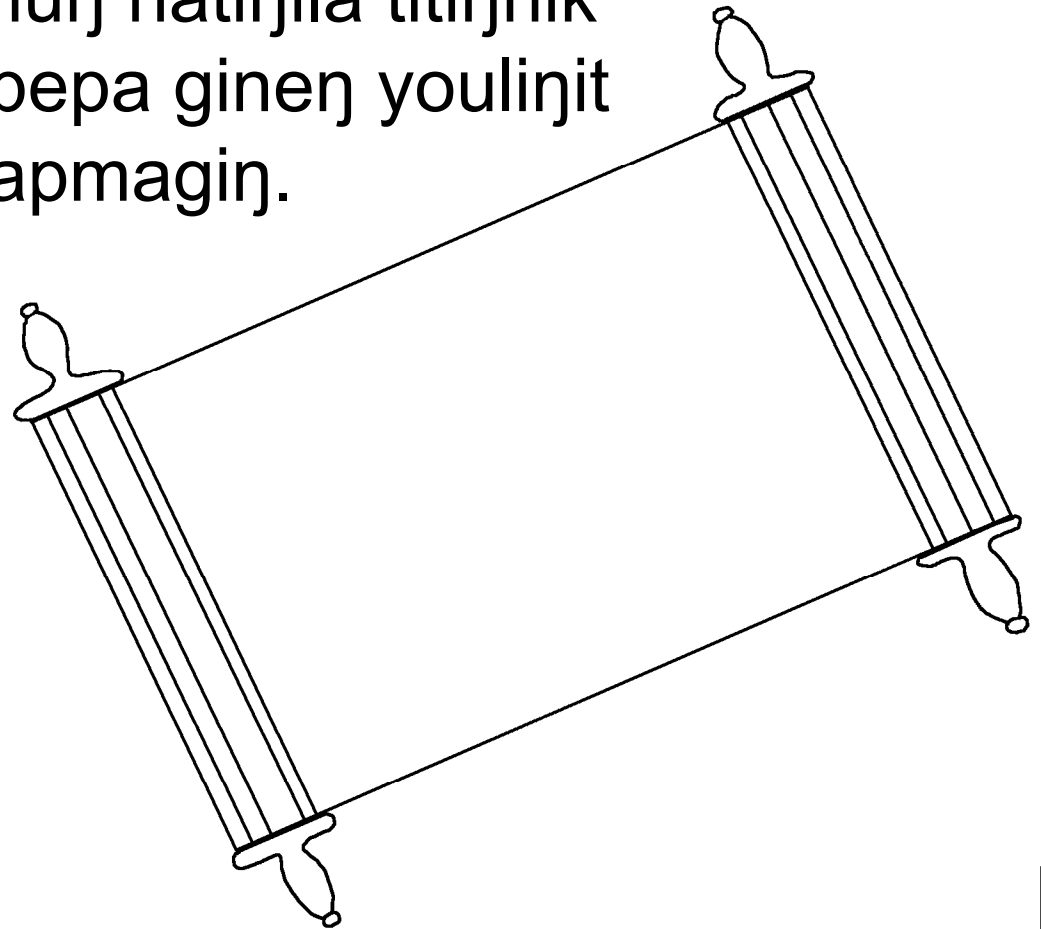

Undun tiŋa kumuŋ dut kumuhi'walaŋ kwet (ham yoyam) adi imenŋwan kudup ha-dalakneŋ moŋgo yakulune fogumuk. Kaŋ metam hatihati fafaŋeniŋ diniŋ pepa gineŋ wohiye moŋ yolohigiŋ heki adi imenŋwan kudup ha-dalakneŋ moŋgo yakulune fogiŋ. Wendi kumuŋ kunakunat 2 tilak.

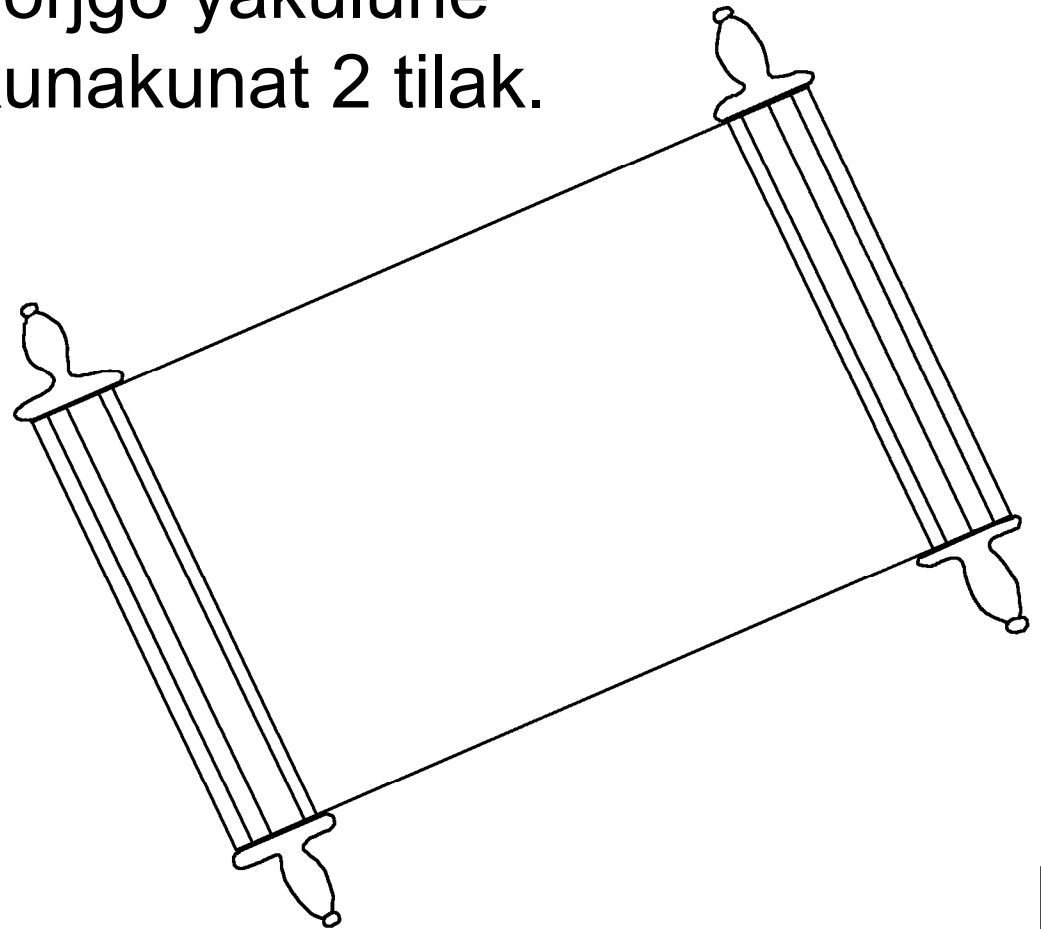

Munabuli en Jesu'walaŋ tam gigitdi indin yoyamuk.
“Du beŋ!” Ala nebek niŋ adi mede i nadiŋa undugon
yobaak, “Du beŋ!” Nebek niŋ adi imedok maŋiŋ
galiune kedem baak. En nebek niŋ adi wendok
nadikaan buŋa hatihati fafaŋeniŋ diniŋ ime tuwanjit
mokit nawaak.

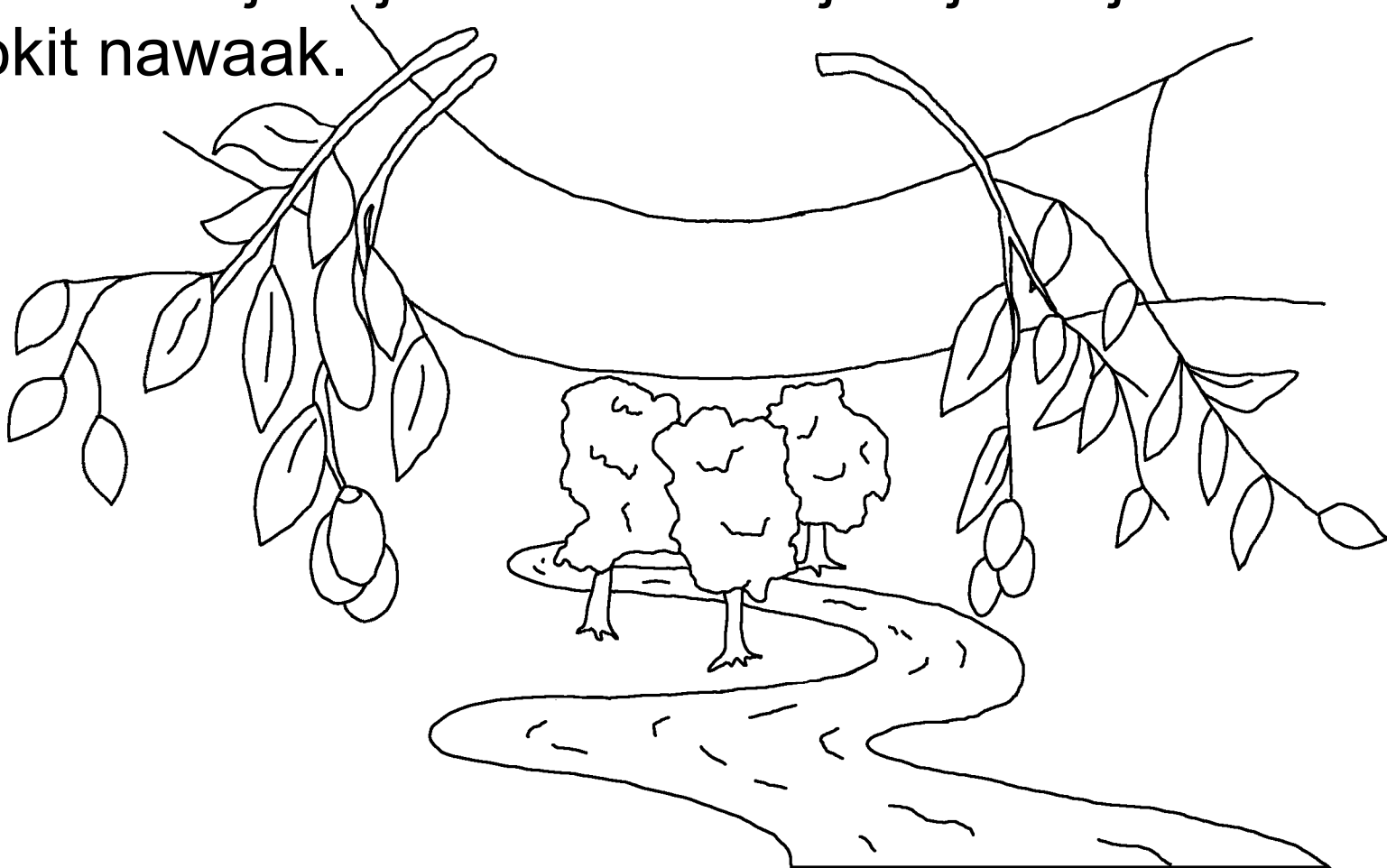

Bepañ adi metam welenđi hinek yabukahileguk
doktiņa Mihiniņ kubugoņ hinek kameu
foguk. Adi unduņ tuguk doktiņa
metam adi nadisukilitimineeņ
hogohogok adi kadaka tiņa
fiit mu tineeņ, adi tobo
hatihati dapmandapmaņnit
mokit kahileneeņ.



Loma 3:23

Indi hogohogok wanakanj kadakanijnit
tubudapmagumun, doktija Bepanj'walanj hatihati
didimeninj kahiledok tuwot mu tiyam.

Loma 6:23

Kadakaninj dininj tuwaninj adi kumunj titindok. Ingonj
Bepanj silonj tobogonjinj dininj foloonj adi Wapumnik Jesu
Kilisto adut kadija hatihati fafaneninj kahiledok.

Hibulu 9:27

Meeninji nai kubugonj hogok kumundok ninijit, kanj
wondok siginenj medenik yodapmanjok yonjit.



Efeso 2:8,9

Nadiin be? Adi silon tobogon tihamuna nadisukilitihik doktiya hehitutumbaguk. Uyadi hide nemek nin tubune mon. Bepan welesilonjin doktiya undun tihamguk. Be kwanai nin tigin doktiya wondinin tuwanin mu hamunguk, uyadi mon. Undun doktiya hide'walañ wohiye mu yonja tilolon dok.

Loma 10:9,10

Indin yobune tuwot tibek. Jesu adi Wapumne, u mede yoyoge folon halaak, en Bepandi Jesu kumon ginenin tubukaikanimguk, u welegedi nadisukilitiya kedebaan hatihati kahilewaan. Diki inden hatak. Welenikdi Jesu nadisukilitimiya metam didimehi titindok en manikdi adi nadisukilitimiyam, u yohautane kotigon ninigitak.



Jon 3:16,17

“Bepañ adi metam welenđi hinek yabukahileguk doktiņa
Mihinįj kubugoņ hinek kameu foguk. Adi unduņ tuguk
doktiņa metam adi nadisukilitimineeņ hogohogok
adi kadaka tiņa fiit mu tineeņ, adi tobo hatihati
dapmandapmaņnit mokit kahileneeņ. Unduņ doktiņa
Bepañ adi Mihinįj kwetfoloņ iņoņ kameu foguk adi metam
mede gineņ yapmeeņ yehitubu-kadaka titiņdok mu
yoņa kameu foguk. Adi tobo yehitubu-loda titiņdok
yoņa kameu foguk.



1 Jon 5:11-13

Kañ titiñ unduñ foloñ Bepañdi medeniñ biyagoñ u tubudakalelak. Bepañdi Hatihati dapmandapmanñit mokit nimguk, kañ Hatihati woñ adi Mihiniñ'walañkade hatak. Me nediyeñ Bepañ Mihiniñdut woon galilak, adi yadi Hatihati u kahilewaak. Eñ me nediyeñ Bepañ Mihiniñdut mu woon galilak adi yadi Hatihati u mu kahilewaak. Nu metam Bepañ Mihiniñ wou nadiña nadisukilitimiin hidi Hatihati dapmandapmanñit mokit haliwoon halaak u agañ kahilegiñ, u nadidakaleneñdok mede i youhamulat.



Jon 14; 2 Kolin 5; Yobihit 4, 21, 22

Storyline by: Edward D. Hughes

Illustrated by: Lazarus
and Alastair Paterson

Adapted by: Sarah S.

Numanggang Bible (nop) © 2005, Wycliffe Bible
Translators, Inc. All rights reserved.

<https://live.bible.is/bible/NOPNTT/GEN/1>

©2026 Bible for Children, Inc.

www.M1914.org

www.bibleforchildren.org

