

[www.BibleForChildren.org](http://www.BibleForChildren.org)



John 14



Soo Te Pabe'e yise numme pumme nakatzimodu mee netamma, "Gi suda sokwamapana. Mooasoo mu ka Te Naa nakabetsea, nuka nakabetsea tuwazoo. Soo Te Naa nobe-kwitu ewow kapa-ga'yoo."



"Nu togesapa, nu gi esaya'e. Nu mease ka Te Naa-baa mu kapadookukwu. Saa'a nu yaasoo kodyu petuse, mu bikakwu Te Naa-matoo. O'no yise mu oosapa nu-no'yookwu."



Nu mumme Te Pabe'e-witu  
tunaka'oedyukudu-matoo tubo'okwu.  
Nu punno'o mu-kwa'nesoo ka Te  
Pabe'e-matoo nanesootuhidu tooe  
tamme tu nekuseka, yise tamme  
tu nanetumoo'oo sapa.



Nu ka Te Naa unnepu Te Pabe'e-witu mu numu  
tunedyooena, oonne'yoona nu yaa  
baa-kumana pagadudu Patmos mee  
naneadu-kooba nakwutuma.

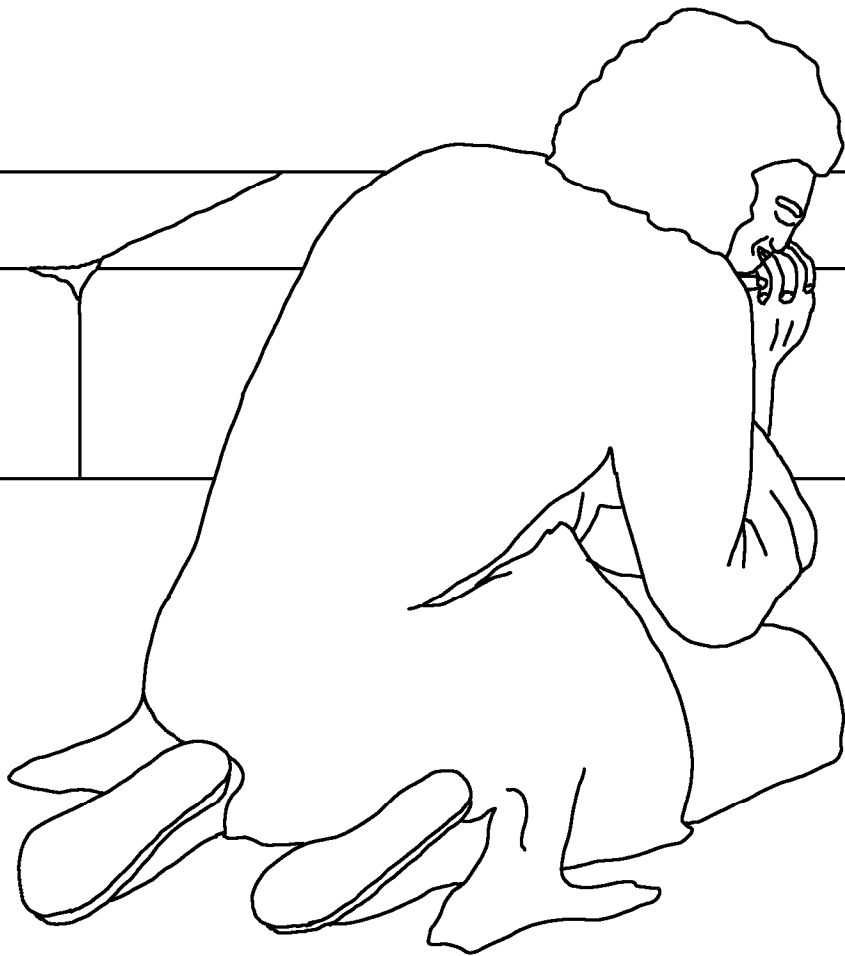

Nu pooha tseboese soo Te Naa Besa Pooha ka  
koomeba tawagatoo e bihookase ka Te Naa-kobena  
numme pepetuga, o ka Te Naa numu nehanegatu-kwi.



No'yoona hee ka Te Naa manumudoopu punno'o mee  
unnegonno, "Te Pabe'e ka mu numu-koobato  
nabatsase meno'o gwetzoidu  
no'oko hemma oonakwa unu  
nansookwuga'e, mu suu' mu  
tamme-kooba namayugwe,  
naduya no'okosoo hemma  
mamanepunnena  
ekow no'oko  
nasootuhipu gi  
mobegwa-ga."

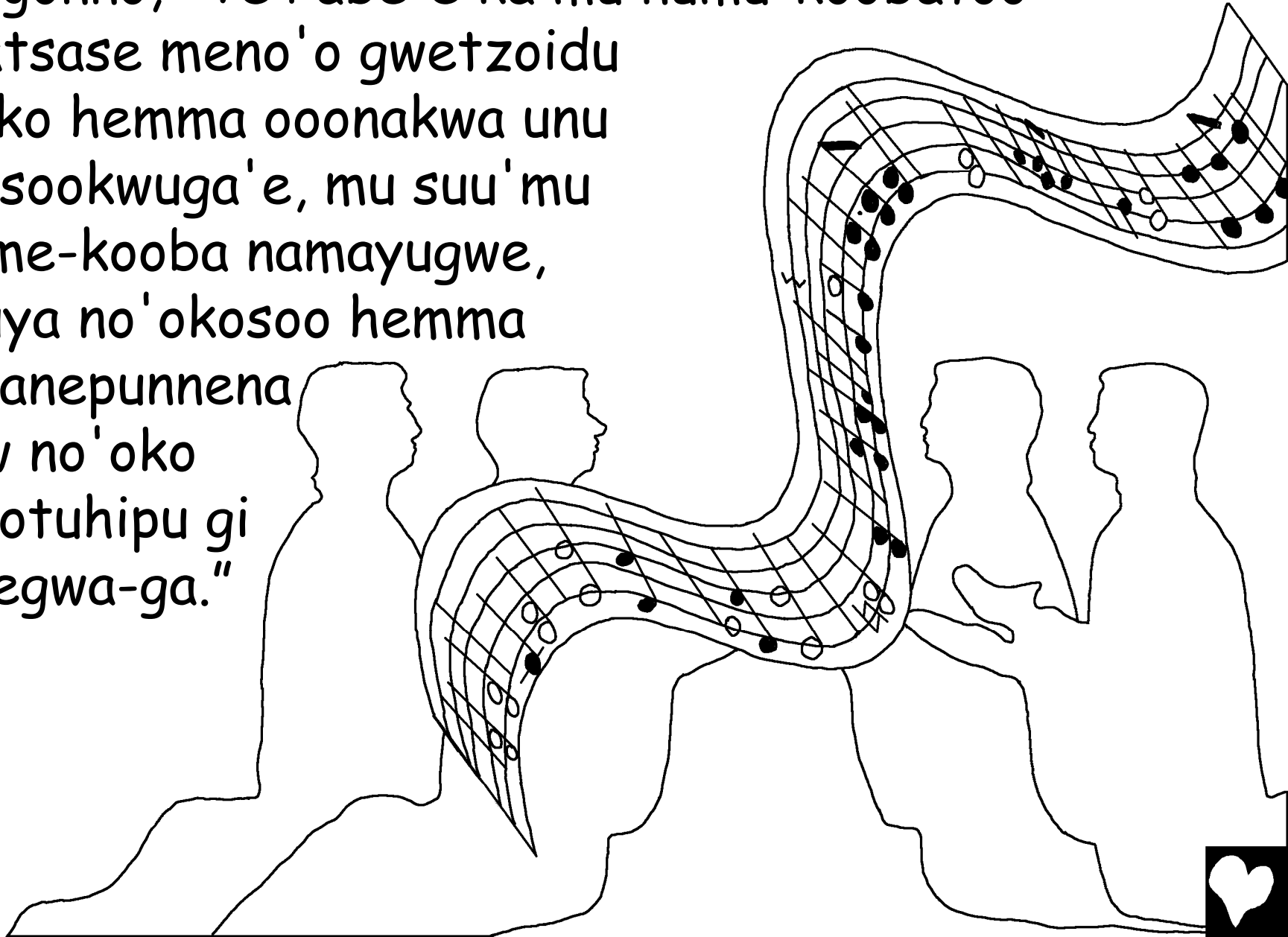

O umuoo Te Pabe'e-wi tunaka'oedyukudu pudu  
teepu-kooba tubewa-ga'yoo. Sumu'yoo Te Naa  
oo-tugana'yoonaa meeoo une, "Meno'o manakwana  
soo Te Naa oosapa tu dooamu-no'yoopunnekwu  
mu oosapa Te Naa-matoo nanesootuhikwu.

Te Naa  
oosapa mu  
doodooamu-gana  
mu mabetseakwu."

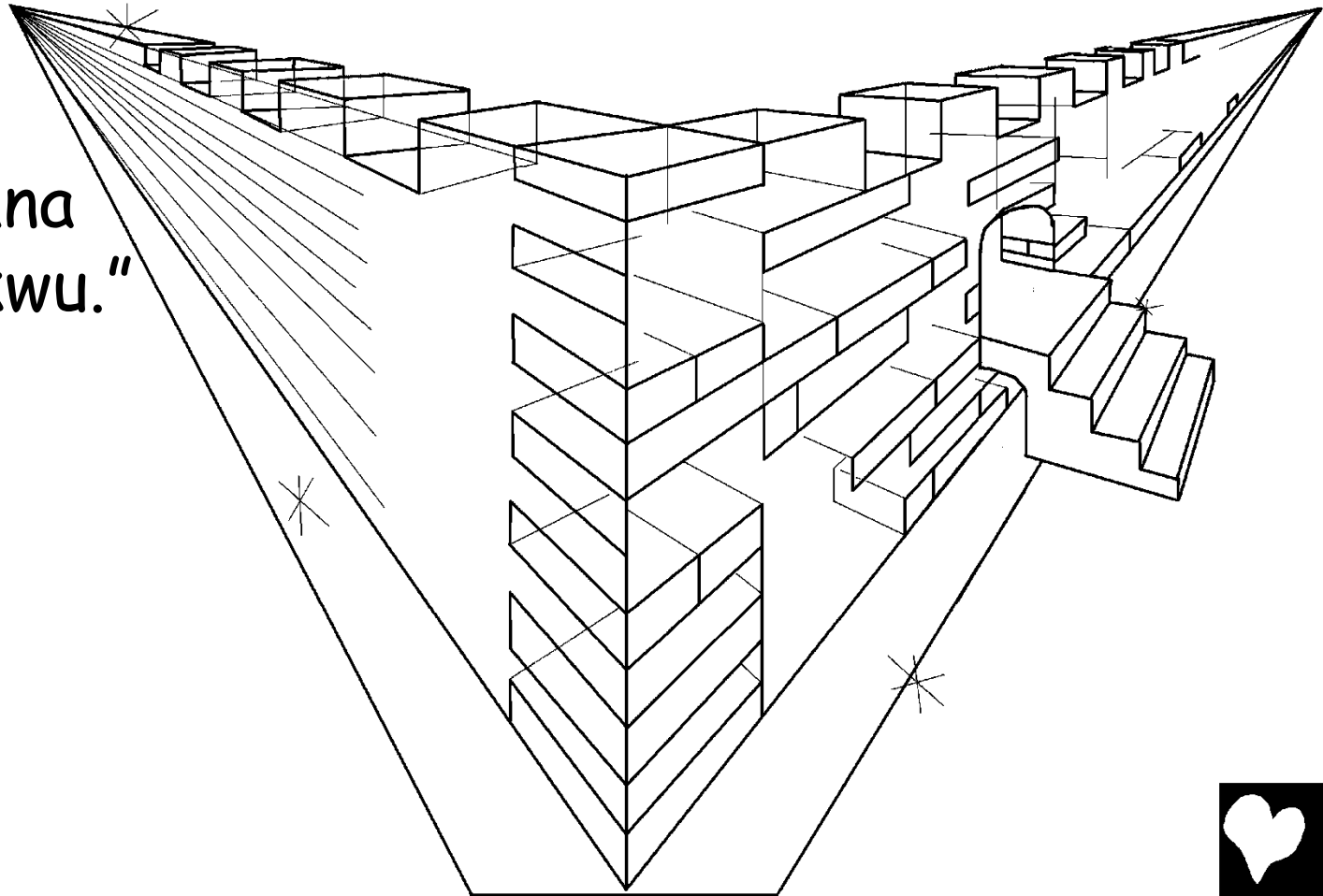

O'no yise Te Naa tumatzidu toha kasa-ga'yoo nuka  
tu pooha poonnekuna, ka besa patatzadyadu gi  
totsa-gakoo baa hoodu ka Te Naa noko Te  
Pabe'e-pukwi'yoona nakwana kemmadu.



No'yoona umu oo doodooamu ka Te Pabe'e no'oko Te  
Naa pooha-toohakwi manemo. Ooonne'yoona gi  
togaba-ga'yoo.

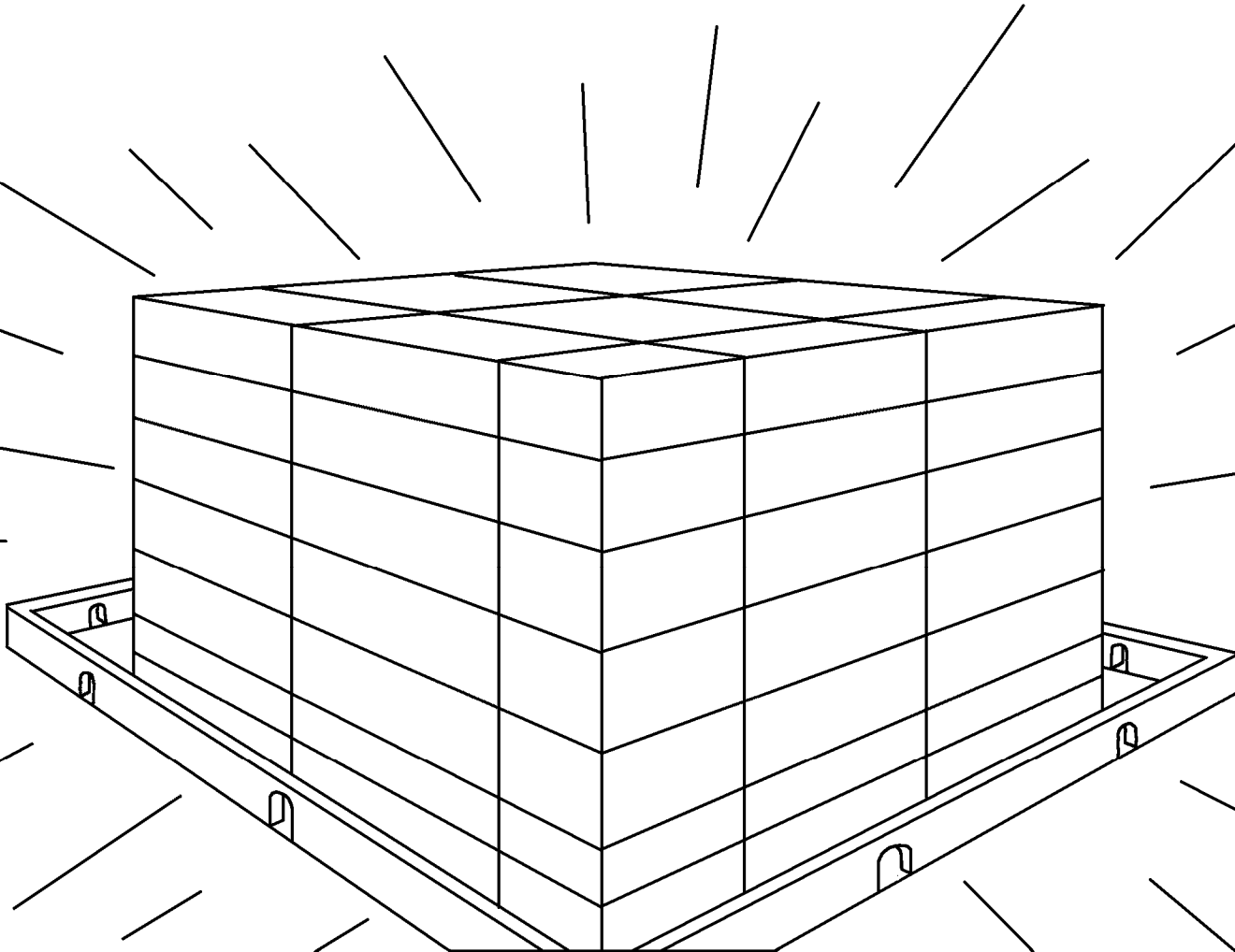

Tooe haga tooe ka Te Naa  
Tooa'ana yise oo-no'yookwu.  
Mu suta'yoo numu gi oe  
nane'egakute mu tooe  
hemmatu tooe  
nanesootuhidu  
punno'o gi oe  
nane'ega-wa'ne'yoo.



"Umu tea'a no'yoona besa  
sokwamana, nuumaba  
gadoo'yoo gi tuikwu."



Tooe hee suta'yoo otuoo gadoo'yookwu. Soo Te  
Naa-no Te Pabe'e o numu nehanepunnena, umu  
oosapa ka Te Naa-matoo nanesootuhina, umuoo  
oosapa Te Naa dooamuna oosapa oo-no'yookwu.



Tuipu numu tooe hano tooe namayosuse, no' obatusoo  
tuipu numu ka Te Naa-kobena konnopunne. Soo Te  
Naa o' nosoo mu manena botugukwu. Sumu'yoo yise  
tuboep ka mu numu oosapa momokwudu naneana  
pukwi nabona punno'o natzakwunahoo.

Mu tuipu numu gi tunaka'oedyukudu  
no'oko tu manemopu-ma  
nanemadabuehoo.

No'yoon ka umu  
tuboep-wi nanabo'o.

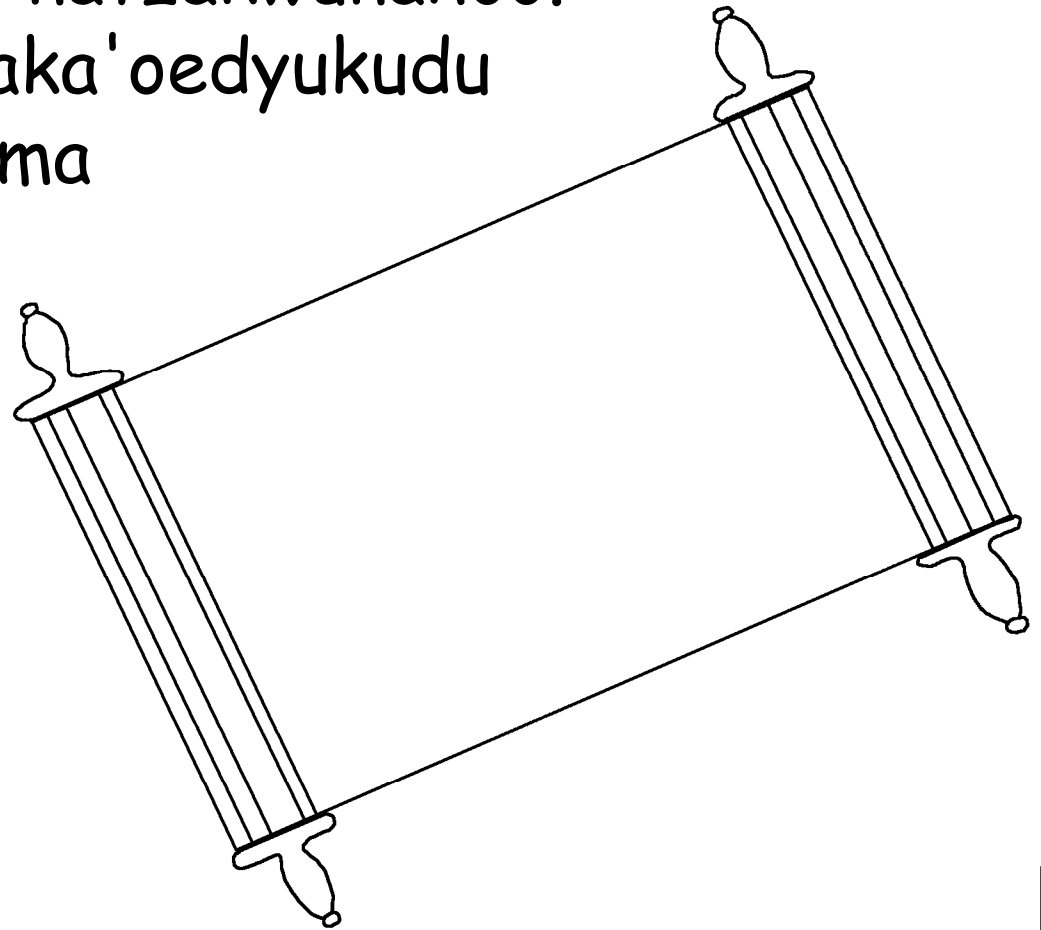

Tooe haga tooe naneana gi ka tubope-wi nabodu numu  
oosapa gwetzoikwuna nasootuhipu ka gi tookedu  
nikatudu-kwa'ne. O'no soo numu ya'ekwuna ka gi  
tookedu goso-kwitoo natzawunihoo. Oosoo  
nikatudu-kwa'ne'yoo Penakwa Numu  
Yaekwuna mee nane'a. Umuoo gi Te  
Naa hee soobedyadu. O'nosoo  
Etza'a unnepu gadoo  
namayugwe, o'no  
manakwana numu  
gi ya'e-wa'ne'yoo.

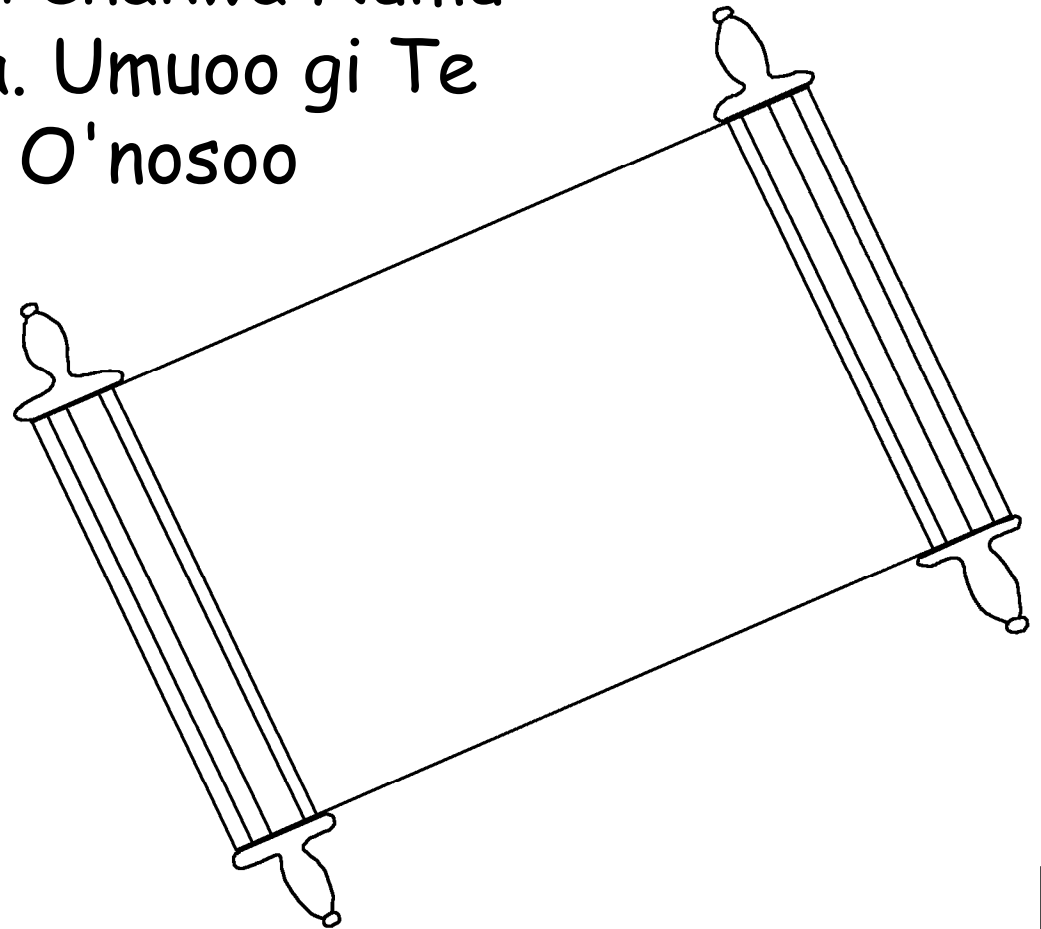

Soo Te Naa Besa Pooha, Te Pabe'e-wi  
tunaka'oedyukudu-no, ka mu yaatoo numu meeoo  
netamma, "Te Pabe'e-toooha manese oo  
naka'oedyukuna, mu ka gi mobegwa-gakoo  
gwetzoibu-ma nasootuhikwu."

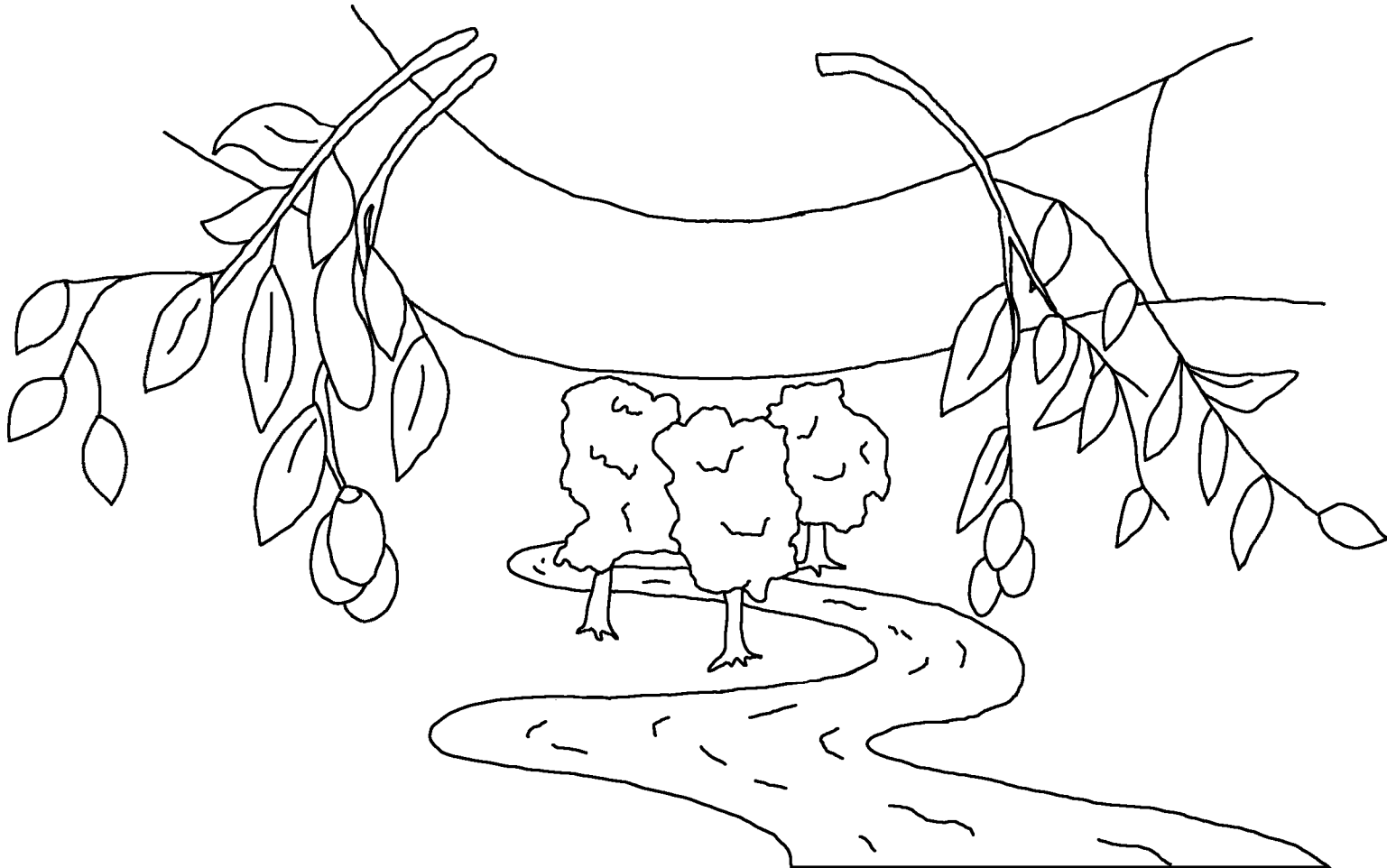

Te Naa no'oko numu ka  
teepu-koobatu besa soobedyana,  
tu besa dooa tamme-koobatoo  
nemawuni. Tooe haga tooe  
nu-kwi tunaka'oedyukudu  
gi ya'ekwu oosapa  
gwetzoinnummekwu.



60

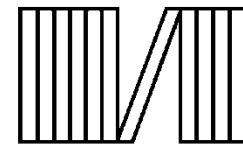

60



Romans 3:23

Tamme ka no'yoona tuma'emukwakupuna, gi ka Te Naa tamme oo netamma-kwa'nesoo manena.

Romans 6:23

Tammesoo tuma'emukwana ka te ko'e, pana soo Te Naa te sootuha'e te gwetzoimokwuna, ka Te Pabe'e Jesus tamme-koobattoo nabatsase.

Hebrews 9:27

No'yoona numu sumusoo ya'eyakwe. Obenakwattoo yise soo Te Naa no'oko te tumatugupu nemadunagakwu.



## Ephesians 2:8,9

Tooe tamme gi ka tamme oo tunetammakuna no'oko mayohopana soo Te Naa te sootuhikwu. Oosoo te magwetzoikwu ka te tunaka'oedyukute. No'yoona tamme gi mee'e nana'unne-wa'ne'yoo, "Numme nummesoo namagwetzoa'e ka besa tumatuguna." Soo Te Naa puusoo tamme sootuhikwu.

## Romans 10:9,10

"Soo Jesus Te Pabe'e," mee'e tamme unnena tamme oo tubetse naka'oedyukuna, soo Te Naa oo ya'e-wikoo oo mayodase, yise oosoo te magwetzoikwu. Tamme ka tunaka'oedyukuna soo Te Naa, "Besa'yoo," mee te netamma, tamme yise ka oo wahana, soo Te Naa te magwetzoa'e.



## John 3:16,17

Te Naa no'oko numu ka teepu-koobatu besa soobedyana, tu besa dooa tamme-koobato nemawuni. Tooe haga tooe nu-kwi tunaka'oedyukudu gi ya'ekwu oosapa gwetzoinnummekwu. Soo E Naa ka yaa teepu-koobatu numu e magwetzoi tuunguna yaatoo e ta'ya, gi nagutza ka mu sutakoo numu kadoo e mayugwe tuunguna.

## 1 John 5:11-13

Soo Te Naa meeoo te tunetammakupu ka Te Pabe'e mane-koobato gi mobegwa-gakwu oosapa te gwetzoimokwuna te sootuhikwu. Soo tooe haga tooe ka Te Pabe'e naka'oedyukudu tu namagwetzoina nasootuhikwu, soo gi tunaka'oedyukudu gi. Nu mumme Te Pabe'e naka'oedyukudu-matoo tubo'o o'no mu nananesootuha'edu numu ka oosapa gi mobegwa-gakoo namagwetzoidu, pumme tu sootuhipu sopedakwadookwu.



John 14; 2 Corinthians 5; Revelation 4, 21, 22

Storyline by: Edward D. Hughes

Illustrated by: Lazarus  
and Alastair Paterson

Adapted by: Sarah S.

Paiute, Northern NT (pao) © 1985, Wycliffe Bible  
Translators, Inc. All rights reserved.

<https://live.bible.is/bible/PAONAB/MAT/1>

©2025 Bible for Children, Inc.

[www.M1914.org](http://www.M1914.org)

[www.bibleforchildren.org](http://www.bibleforchildren.org)

