

www.BibleForChildren.org



Johannes 14



"Losset eiyah hatza nett gedruvveld sei; glawvet an Gott un glawvet aw an mich. In mei Faddah sei haus sinn feel shtubba. Vann's nett so veah, hett ich eich's ksawt. Ich gay un risht en blatz fa eich. Un vann ich gay un en blatz risht fa eich, dann kumm ich viddah zrikk un nemm eich zu miah, so es vo ich binn datt zaylet diah aw sei."

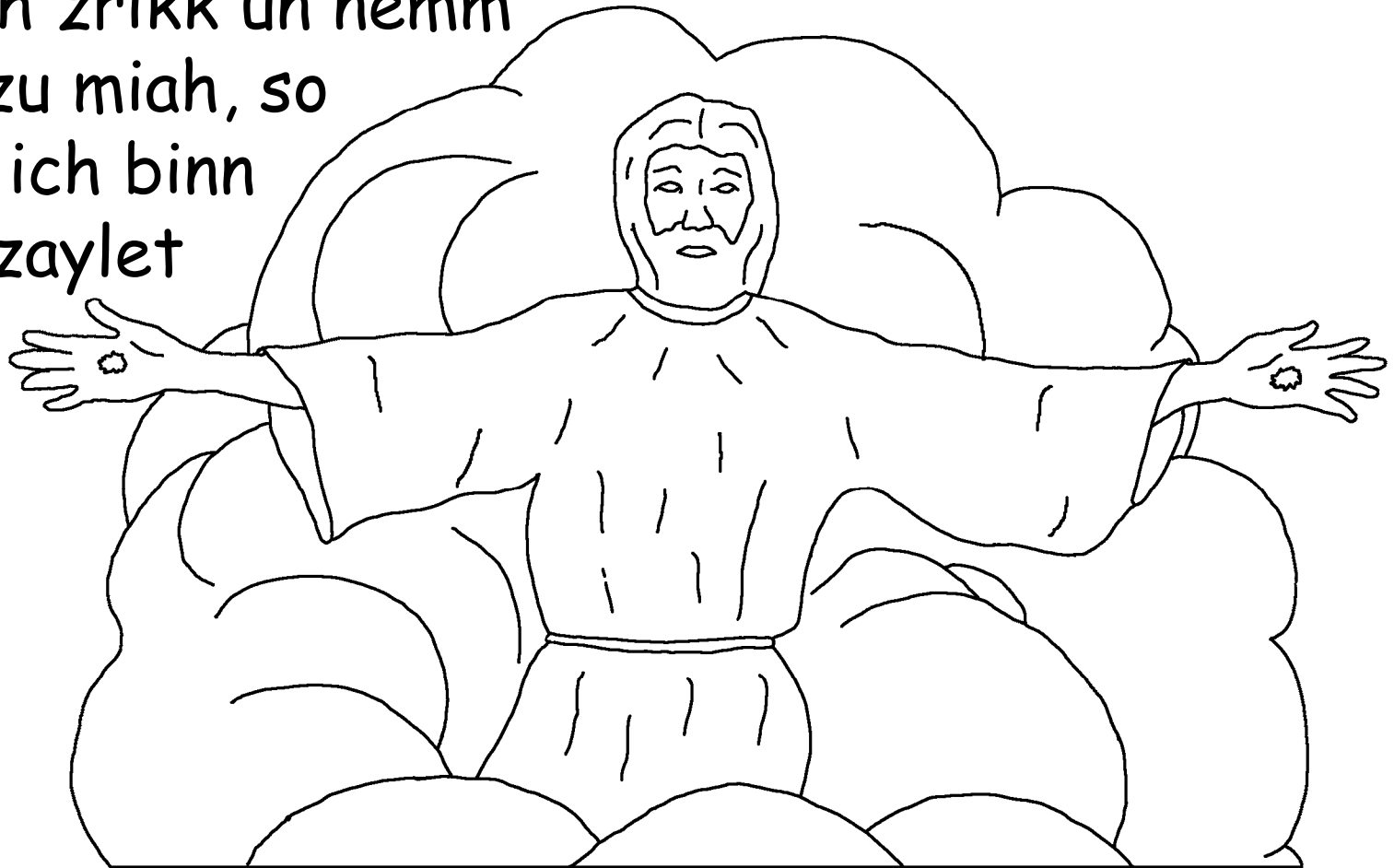

Ich da Johannes binn eiyah broodah, un en
mitt-daylah mitt eich in di dreebsawl, im
Kaynich-Reich un in di geduld funn

Jesus Christus. Ich voah
uf em island es Patmos



hayst deich's Vatt
funn Gott un's
zeiknis funn Jesus
Christus.



Un grawt voahrich im Geisht, un gukk moll, en
kaynich-shtool hott datt kshtanna im Himmel un
aynah hott uf em kaynich-shtool kokt.

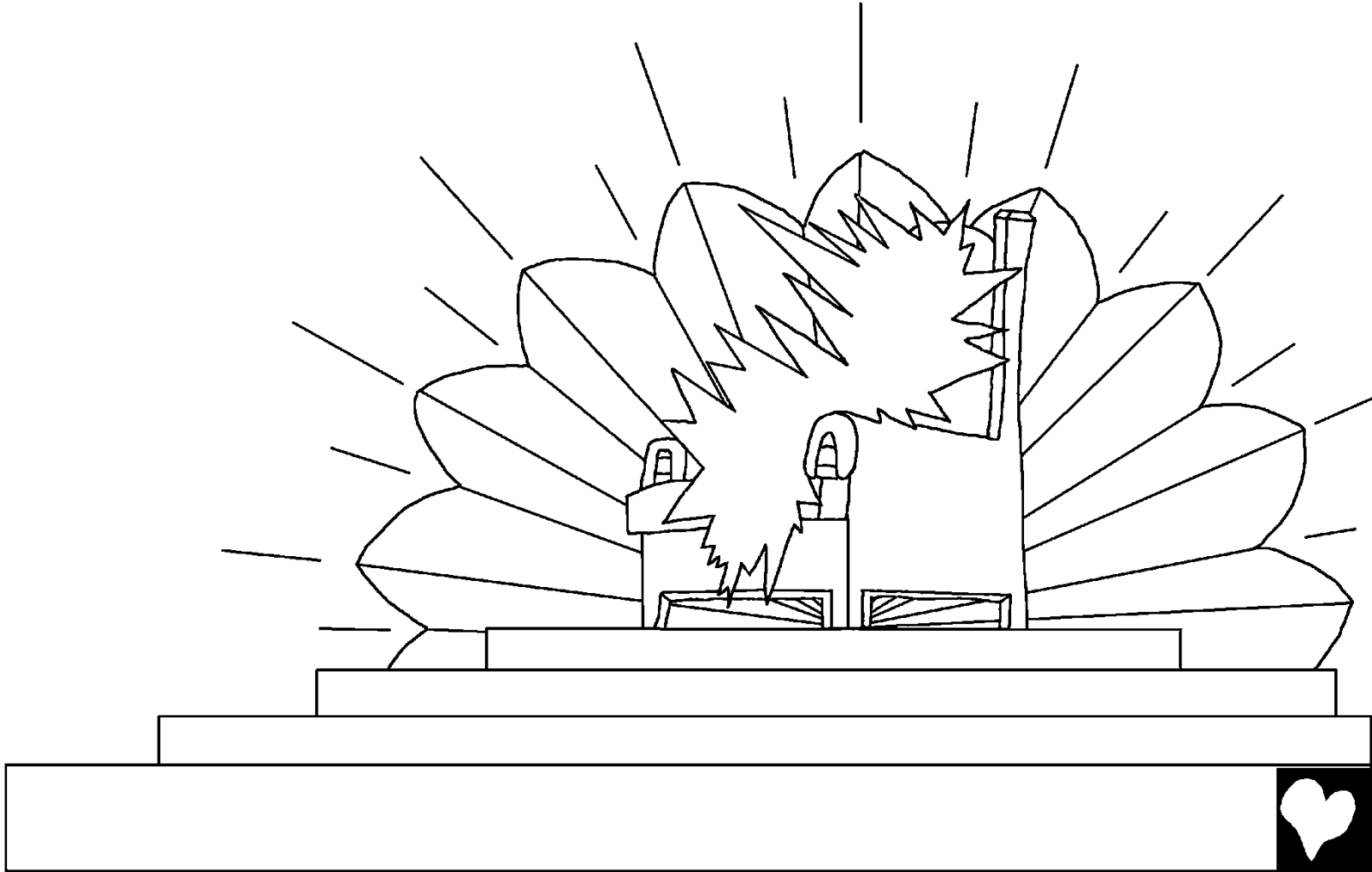

Un alli kshaffa ding im Himmel, uf di eaht, unnich di
eaht, im say un alles es drinn is—dee havvich awl
keacht sawwa, "Lohb, eah,
hallichkeit, un graft sei zu demm
vo uf em kaynich-shtool hokt un
zumm Lamm fa immah un immah."

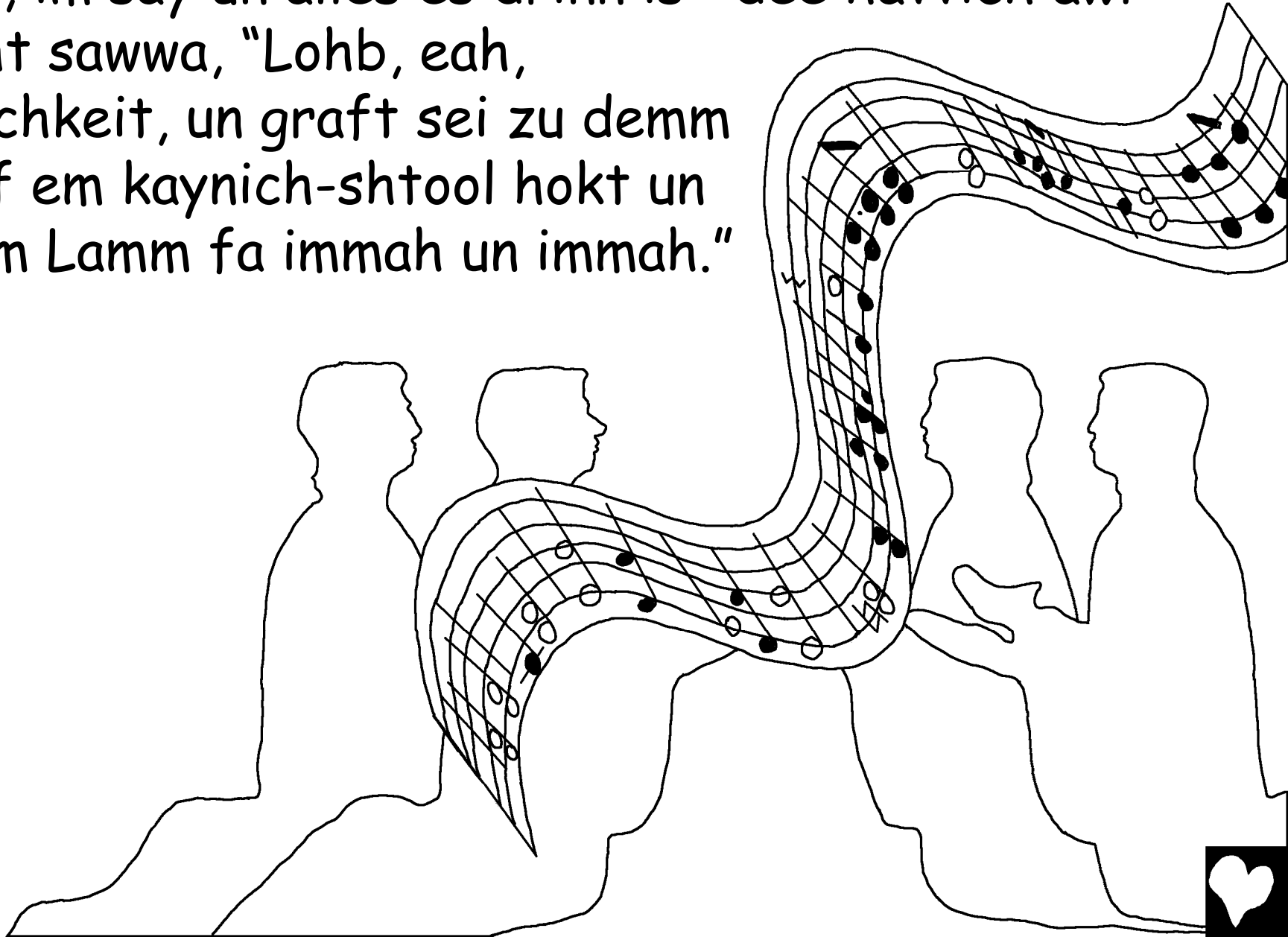

Un ich, da Johannes, habb di heilich shtatt, di nei Jerusalem, ksenna runnah kumma funn Gott aus em Himmel. See voah grisht vi en hochtzych-maydel es sich shay ohgedu hott fa iahra mann. No habb ich en laudi shtimm fumm Himmel keacht sawwa, "Gukk moll,

nau is di vohnung funn Gott bei di mensha, un eah zayld bei eena layva. Si zayla sei leit sei, un Gott selvaht zayld bei eena sei, un iahra Gott sei."

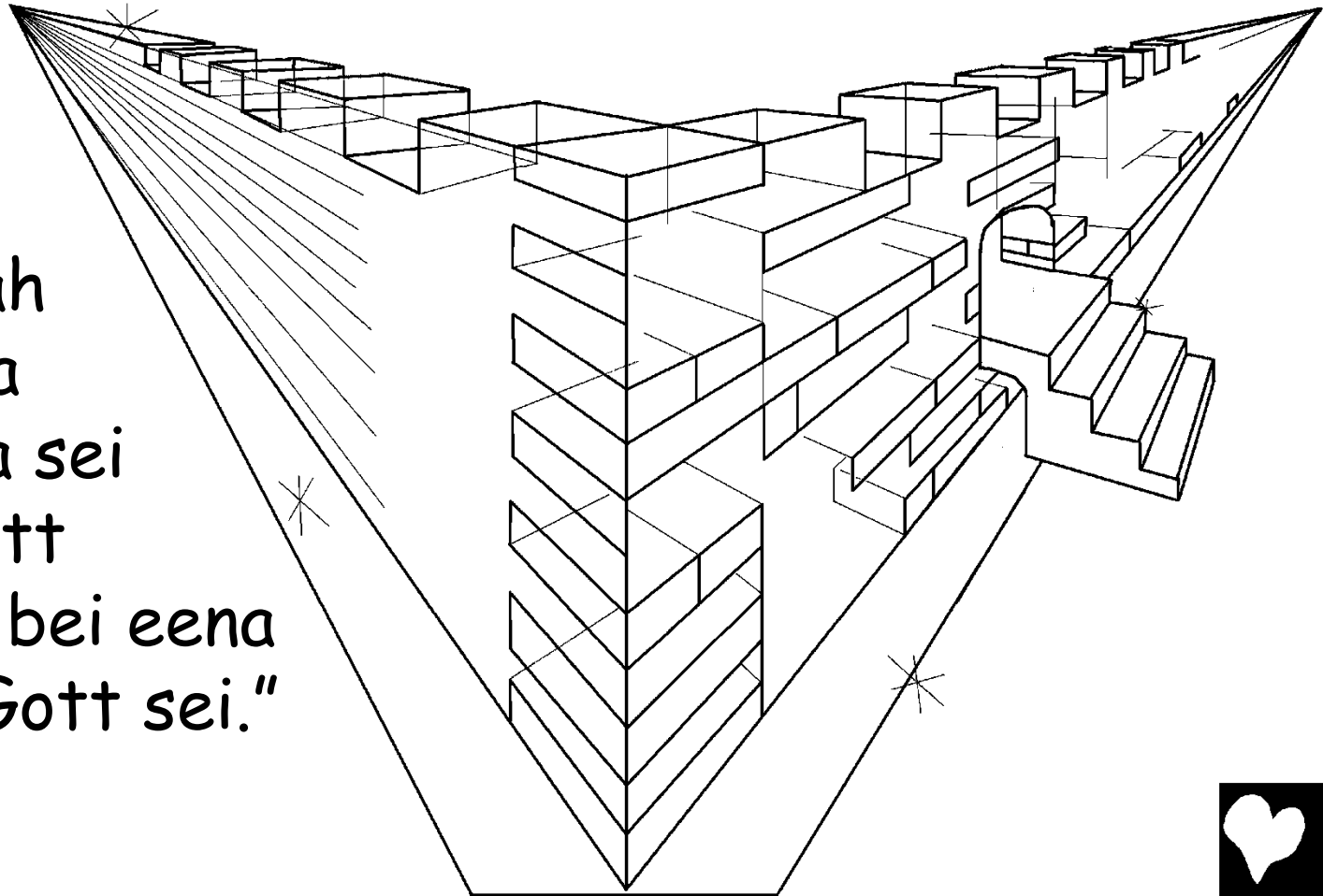

No hott da engel miah en revvah fumm vassah funn
layva gvissa. Eah voah so klich es crystal-glaws. Deah
revvah is fumm kaynich-shtool funn Gott un em
Lamm kumma, un is deich di mitt funn di shtrohs
funn di shtatt gloffa.

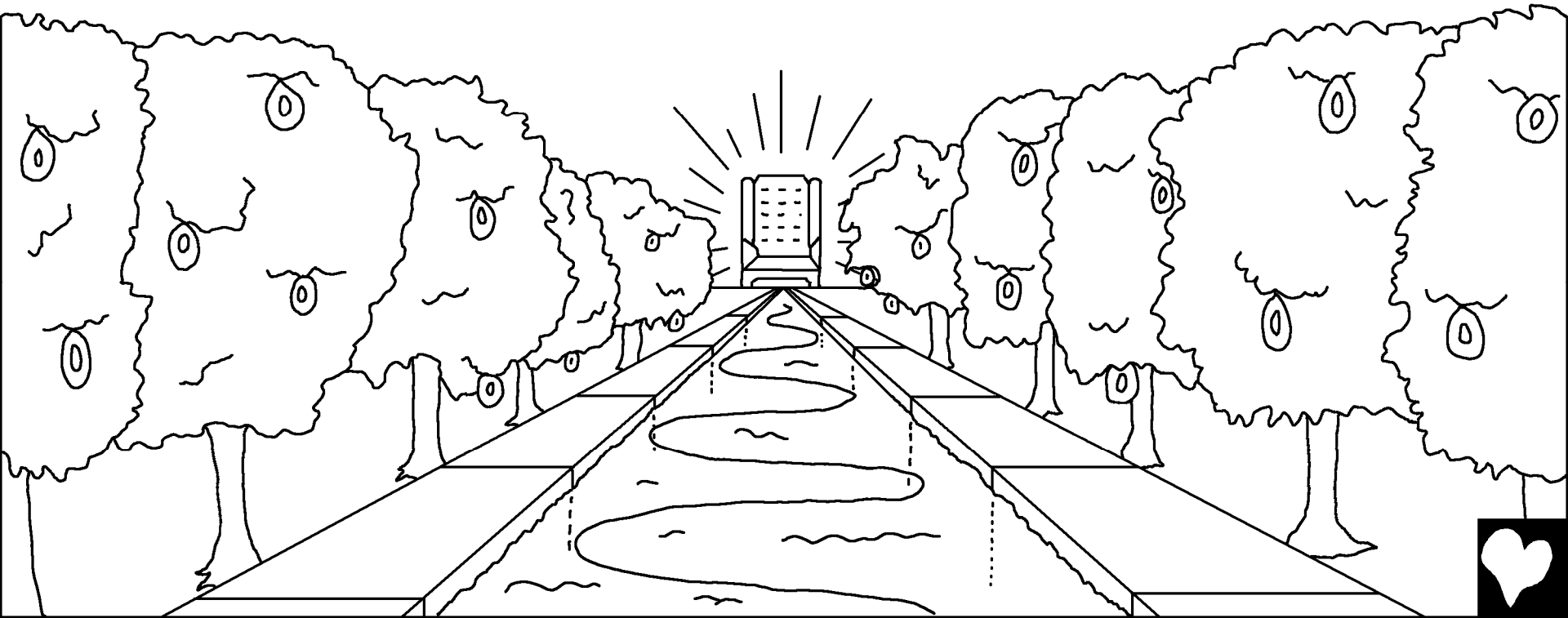

Di shtatt hott kenn sunn gebraucht adda moon
fa uf see sheina, fa di hallichkeit funn Gott hott
see uf glicht, un's Lamm voah iahra licht.

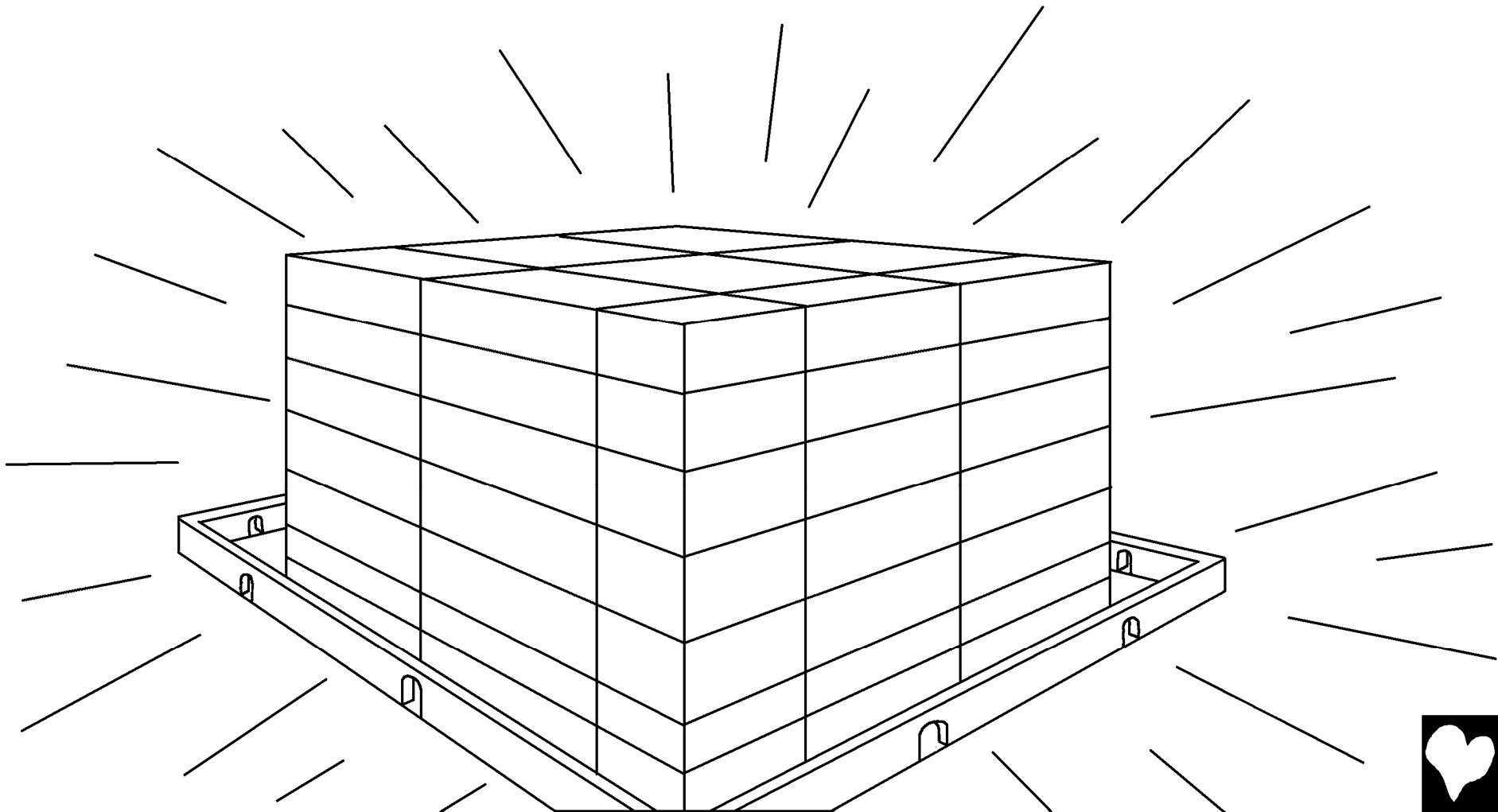

Nix unreines zayld nei gay, un aw nett ennich ebbah
es leekt adda shandlichi sachu dutt. Yusht selli vo
iahra nayma im Lamm sei
buch funn layva kshrivva
grikt henn kenna nei gay.



"Gott zayld awl's awwa-vassah
aus iahra awwa butza, un's
zayld kenn shtauves, adda
heiles, adda brilles, adda
shmatza may sei, fa di alda
sacha sinn faganga."



Un's soll nimmi lengah ennichah fluch sei. Da
kaynich-shtool funn Gott un fumm Lamm zayld
in di shtatt sei, un sei gnechta zayla een deena.
Si zayla sei ksicht sayna un sei nohma zayld uf
iahra shtann sei.



Un ich habb di dohda, grohs un glay, ksenna fannich
Gott shtay, un di bichah voahra uf gmacht, un noch
en buch voah uf gmacht. Dess is es buch funn layva.
Di dohda voahra gricht bei vass kshrivva voah in di
bichah, bei vass si gedu katt henn. Un
vann ennich ebbah sei nohma nett
kshrivva kfunna gvest voah im
buch funn layva, dann
voah eah in da say
funn feiyah
kshmissa.

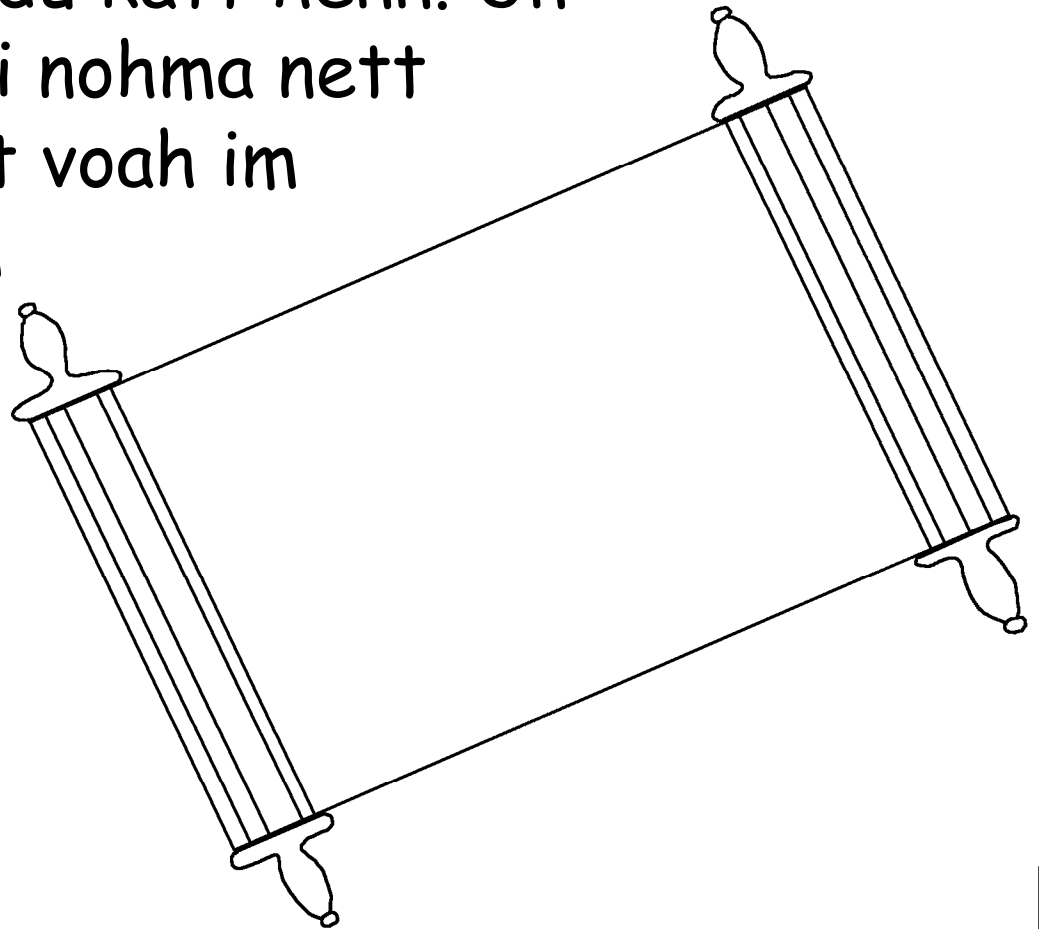

Da Geisht un's hochtzych-maydel sawwa, "Kumm." Un
loss deah vo heah, sawwa, "Kumm." Un loss deah vo
dashtich is kumma. Un ennich ebbah es vill, loss
een's vassah funn layva nemma unni's betzawla.



Fa Gott hott di veld so leeb katt es
eah sei aynsishtah geboahranah
Sohn gevva hott, so es awl dee vo
an een glawva, nett faloahra
gay sella, avvah sella
ayvich layva havva.



Römer 3:23

Fa alli-ebbah hott ksindicht, un langd
nett di hallichkeit funn Gott.

Römer 6:23

Fa da lohn funn di sind is da doht, avvah's frei kshenk
funn Gott is ayvich layva in unsahm Hah Jesus Christus.

Hebräer 9:27

So vi da mensh aymol shtauva muss,
un noch sellem kumd's gericht,

Epheser 2:8,9

Fa bei gnawt voahret diah saylich gmacht deich da
glawva; un dess is nett funn eich selvaht, es is es kshenk
funn Gott, nett es en fadeensht funn verka,
so es nimmand braekka kann diveyya.



Römer 10:9,10

Fa vann du bekensht mitt deim maul es Jesus da Hah is, un glawbsht in deim hatz es Gott een uf gvekt hott funn di dohda, dann vasht du saylich. Mitt em hatz du ett en mann glawva un vatt gerecht, un mitt em maul du ett en mann bekenna un vatt saylich.

Johannes 3:16,17

Fa Gott hott di veld so leeb katt es eah sei aynsishtah geboahranah Sohn gevva hott, so es awl dee vo an een glawva, nett faloahra gay sella, avvah sella ayvich layva havva. Fa Gott hott sei Sohn nett in di veld kshikt fa di veld fadamma, avvah es di veld deich een saylich vadda kann.



1 Johannes 5:11-13

Un dess is es zeiknis, es Gott uns ayvich layva gevva hott, un dess layva is in sei Sohn. Deah vo da Sohn hott, hott layva; deah vo da Sohn funn Gott nett hott, hott nett layva. Dee sacha havvich kshrivva zu eich vo glawva an da nohma funn Gott sei Sohn, so es diah vissa kennet es diah ayvich layva hend, un es diah glawva kennet an da nohma funn Gott sei Sohn.



Johannes 14; 2 Korinther 5;
Di Offenbarung 4, 21, 22

Storyline by: Edward D. Hughes

Illustrated by: Lazarus
and Alastair Paterson

Adapted by: Sarah S.

Pennsylvania Dutch Bible (pdc) © 2016, Wycliffe
Bible Translators, Inc. All rights reserved.

<https://live.bible.is/bible/PDCWYI/GEN/1>

©2026 Bible for Children, Inc.

www.M1914.org

www.bibleforchildren.org

