

www.BibleForChildren.org



SAN JUAN 14



'Mimich́tam, odoy anyáctaami íñanamanjōm iga ich
anicpa. Cupictaami Dios, acupictaamítim mex aich.
Jém anJatun Dios iticciim tsam it jém wıtampic lugar
juť nicpa miitítam. Meega da idic_i, da idic mannímáy.
Nicpa manwıtsagáy tum lugar para mimich́tam.

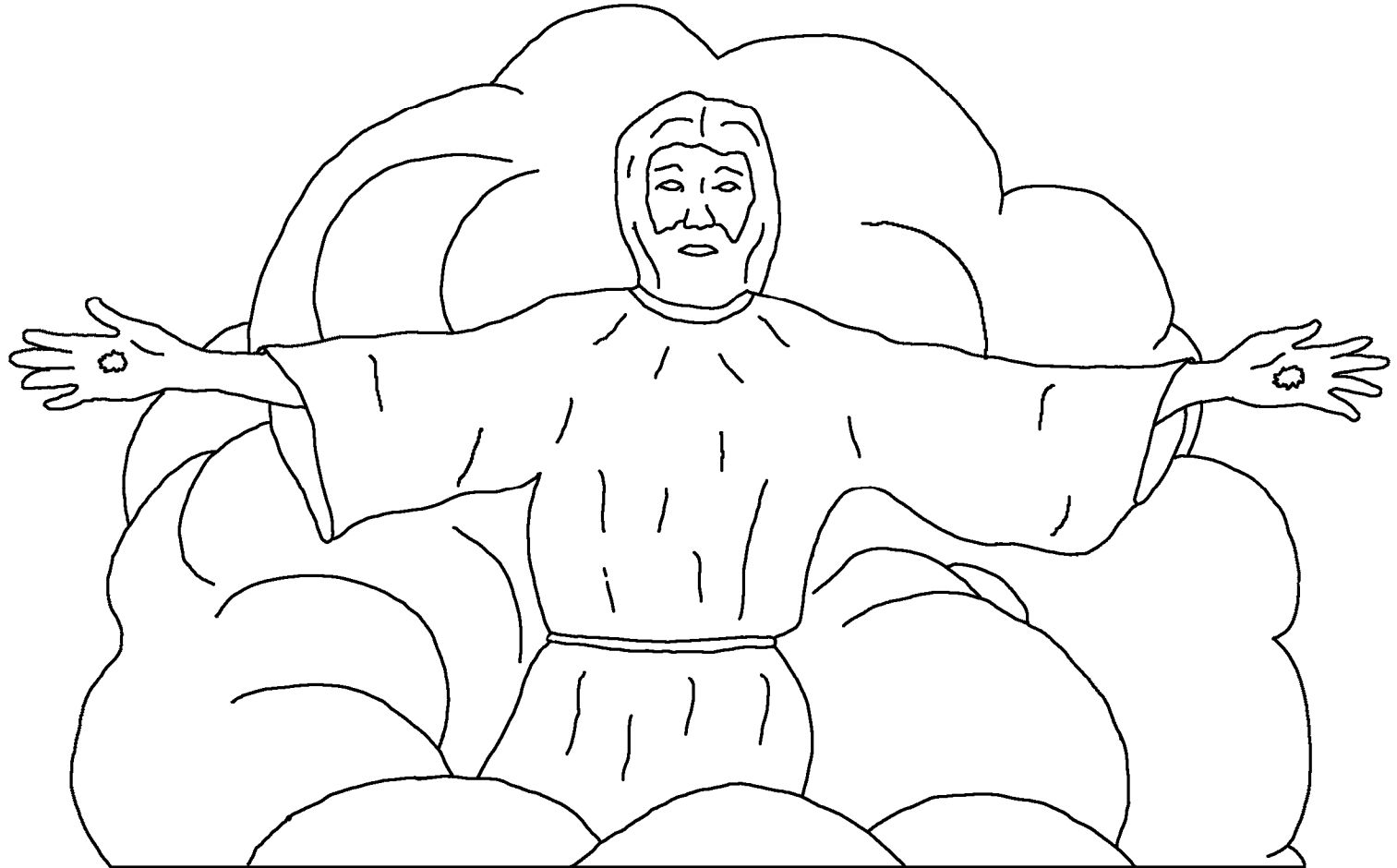

Siiga n̄c̄pa maṇw̄ṭsagáy t̄m̄ lugar para mimich̄tam,
jes̄ic amiñgac̄pa eyb̄ic iga manan̄ictámpa, iga jūt aít̄pa
aich̄ jem̄tim miíttámpa mimich̄tam.



Mant̄iwitam, ich aXiwan, manacjodónap iga ich
annascanet̄im jém yaachaji juuts mimicht̄am
jém tánQ̄mi Cristo icuyucm̄i.

Je tsam tayoxpát̄pa iga
tanyaach̄íypa iganam

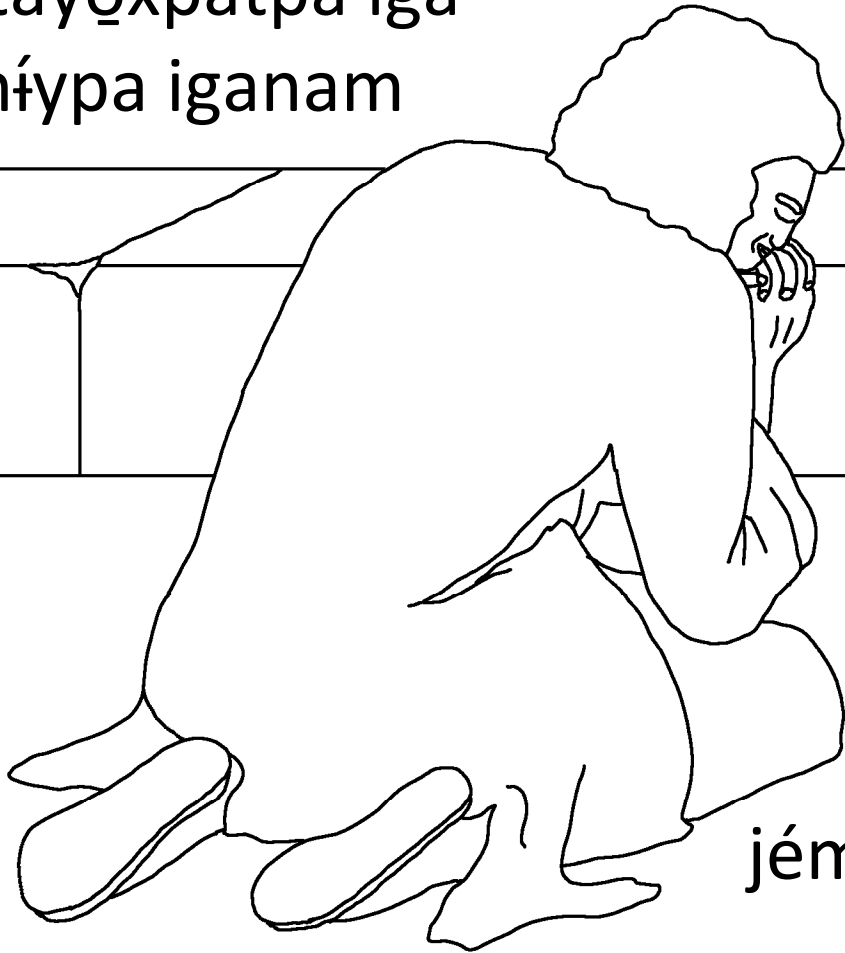

tananjóct̄ampa jém
jama iga nicpa
tawagaīti jūt injacpa
jém tánQ̄mi Cristo.



Apajta jém isla iñiyi Patmos porque anañmatpa
jém Dios inmañi y anañmatpa iga jém
Jesucristo tawiwadáypa.

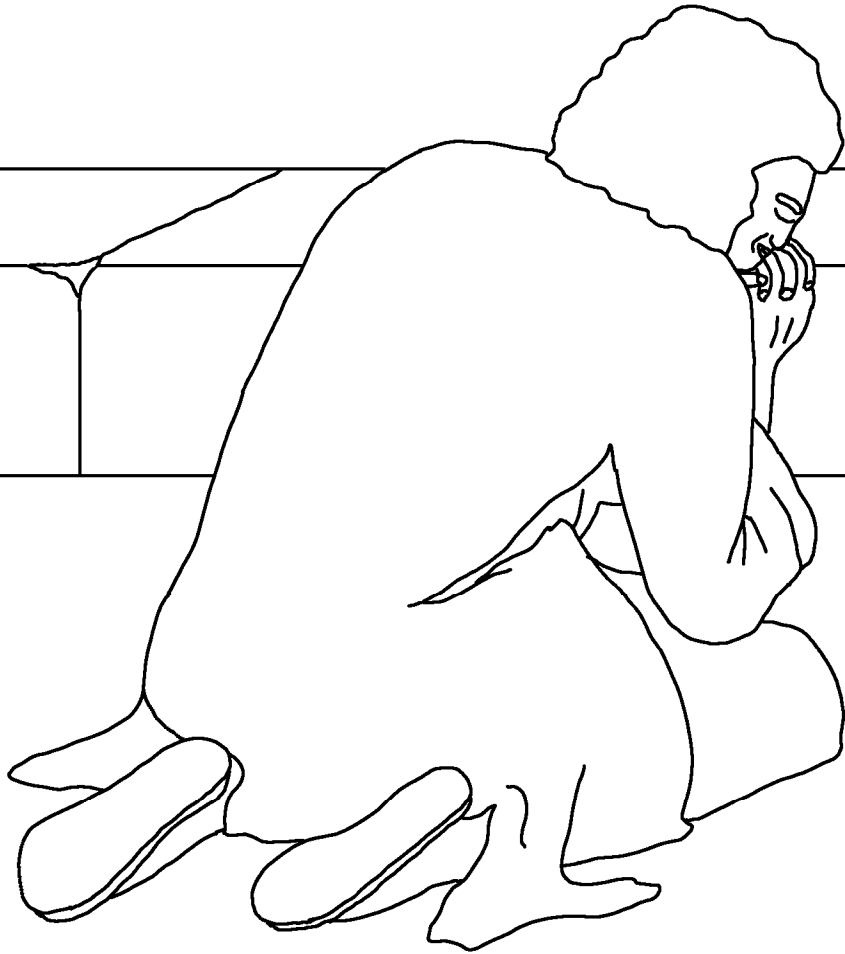

Jesic jeeti rato tsam anait jem Dios iAnama. Anix iga tunne tum anjagooyi iconcuy sinyucmi. Coññim jem iconcuyyucmi.



Ammatonj̄im iga j̄iyajpa it̄umpiy j̄em Dios iw̄ati, j̄em
ityajw̄ip sinyucm̄i, j̄em it̄yajw̄ip naxyucm̄i, j̄em
ityajw̄ip nasc̄im, j̄em it̄yajw̄ip j̄em
lamar y it̄umpiy cosa jūtinquej.

Nimyajpa: W̄i iga tan̄w̄iwadayt̄amiñ
j̄em coñw̄ip j̄em anjagooyi
icoñcuyyucm̄i y j̄em Cordero para
it̄umpiy tiempo.

Tan̄cujipt̄ampa,
tanchiit̄ampa
gloria,
an̄w̄ianj̄amta
iga
anjact̄ampa.

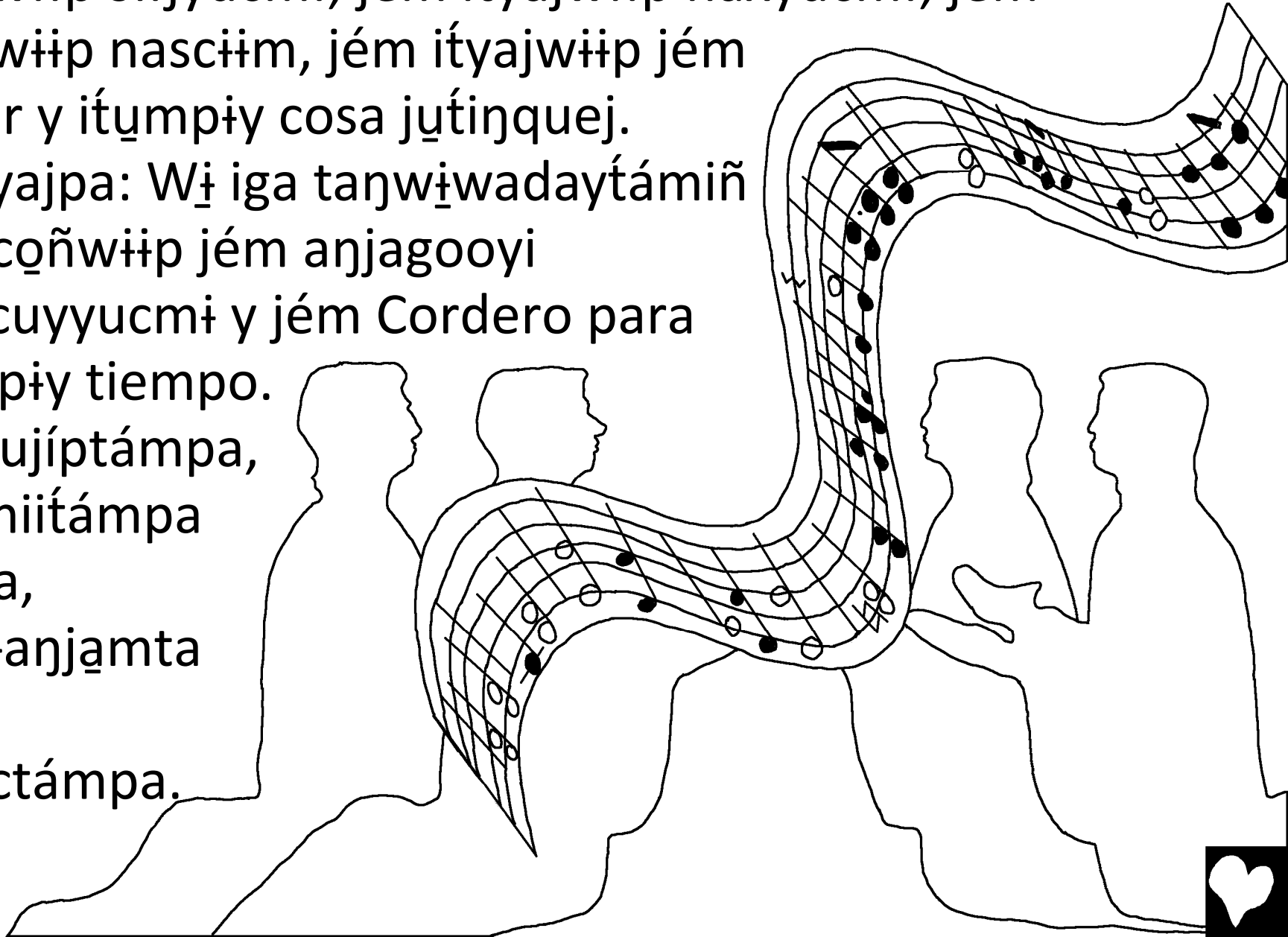

łch aXiwān ānix jēm wibic attebet, jēm jomipic
Jerusalén, quetpa sinyucmi Dios iwiñjom. Wıtsacneum
juuts tım woñi jēm iniitwıip trato iga jáyıpa. Tsam
wıcuyajne iga ipıctsonpa jēm iwıdaya. Jesic ammaton
tım mijpic jıyi sinyucmi. Nımpa: —ıMatonıtaami!

Sıip miñ
iwaganaıtiyaj
Dios jēm
pıxiñtam. Jeeyaj
tsıy juuts Dios
ipıxiñtam y Dios tsıy
juuts jēm pıxiñtam
ıDios.

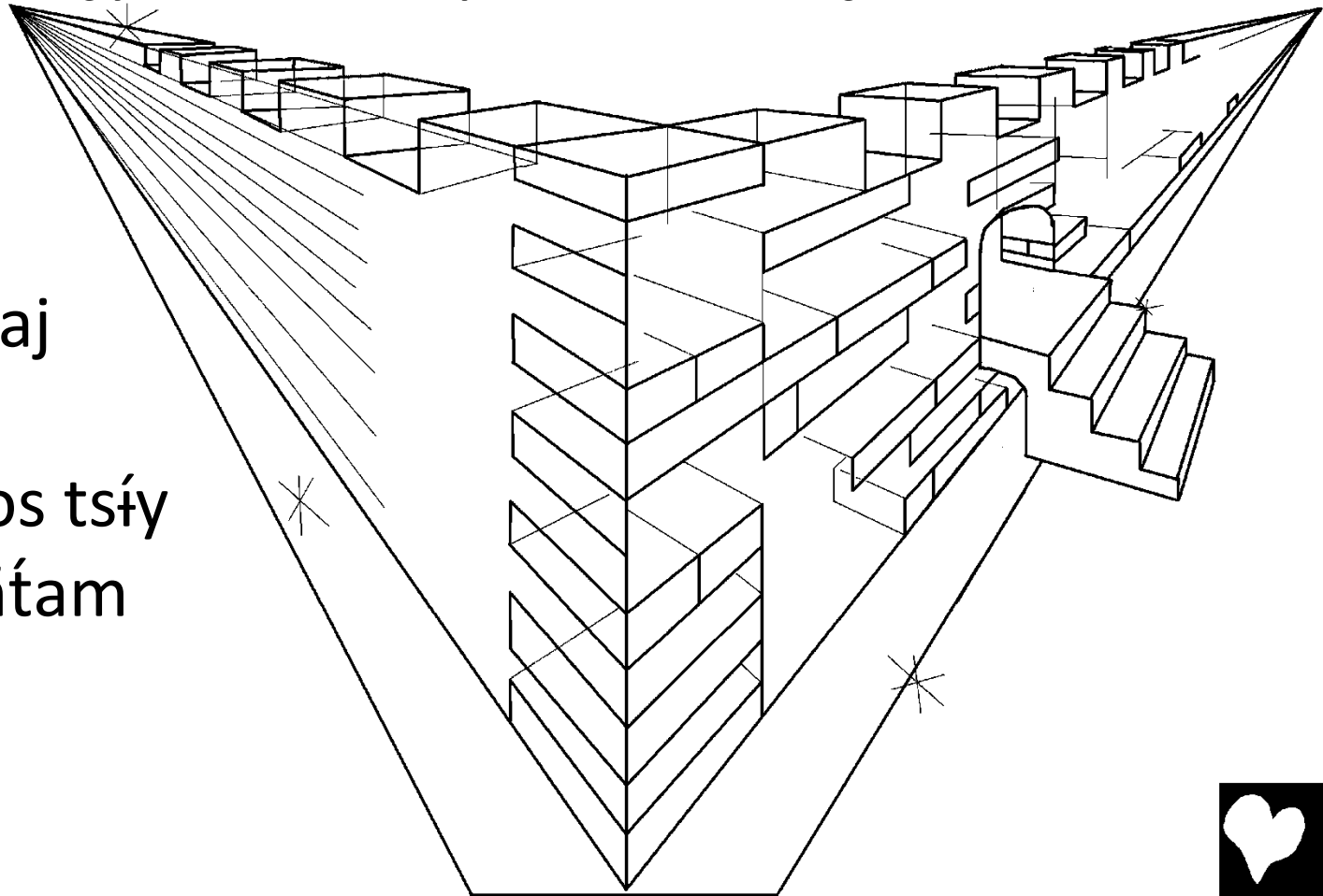

Ocmi jém sɪnyucmɪpɪc pɪxiñ anquejáy tum wɪbɪc nɪ jém
tachiipáppɪc vida jém dápic cuyajpa. Tsam cunajne jém
nɪ juuts cristal. Putpa jém anjagooyi icoñcuycucɪm juɥ
injacpa Dios y juɥ injacpa jém Cordero.



Jém attebet dátim ixunpa jém jama ni jém poya iga
iyicquejpa porque Dios ichoça iyicquejpa y jém Cordero
je jém ijucti.

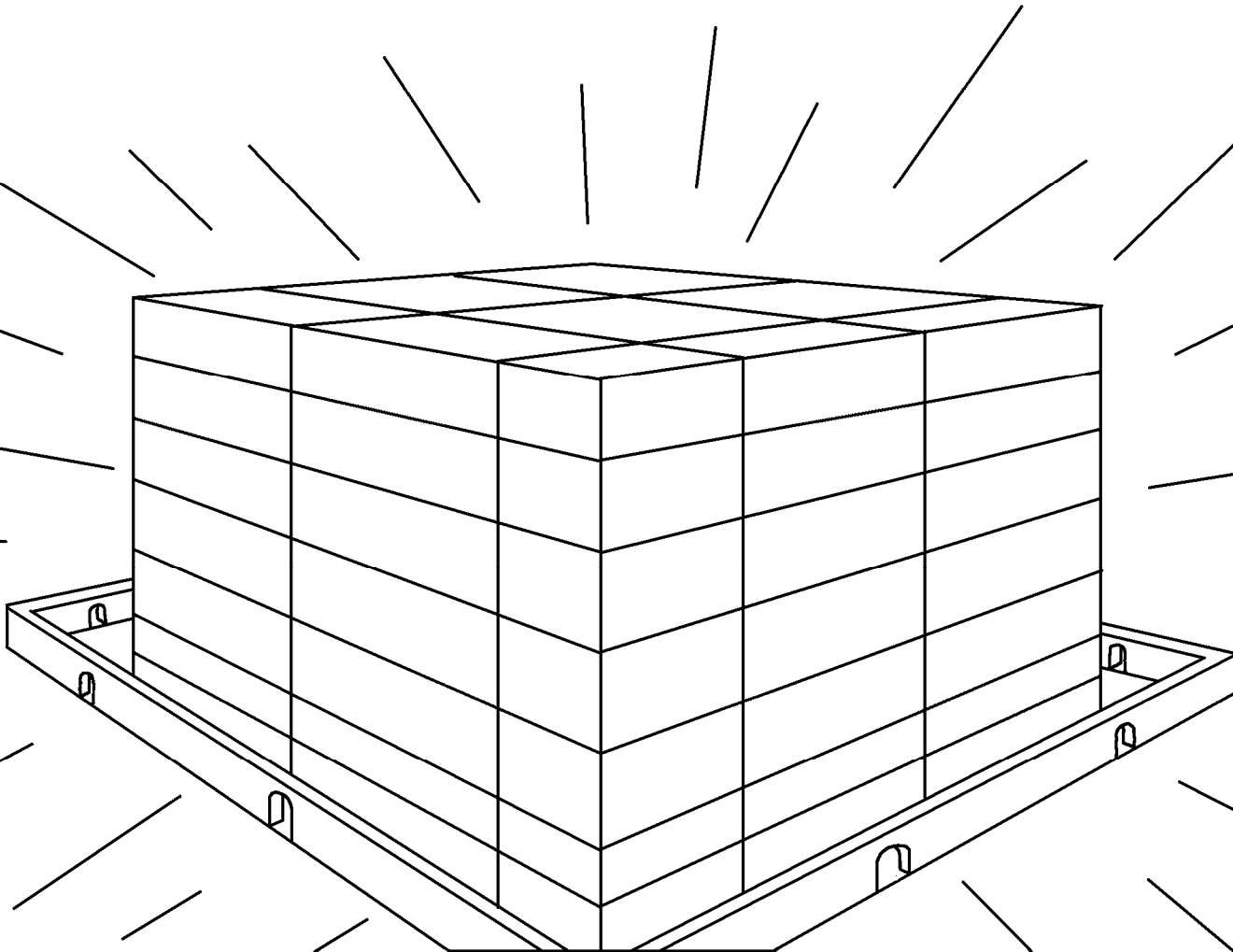

Pero jém malopíc cosa dá tigiypa
jem. Dátim tigiypa jém jóyixoypaap
ni jém migoypaap. Solamente
tigiyyajpa jém p̄ixiñtam jém
jaycámnetaw̄iip iñ̄iyi
jém Cordero ilibrojom
jém ichiiñew̄iip jém
vida jém dápic cuyajpa.



Dios icujicháypa jém ipixiñtam
iixcañi. Dam más caaba jém
pixiñtam. Da i jém anyaaqui.
Dam weyjajpa. Dam i jém toya.
Cuyajneum jém wiñtipic cosa.



Jemíc dá j jem cosa dápic wı́, dam j ijı́ycámne jem
castigo. Pero it jem attebet jem más mı́jpic anjagooyi
icoñcuy juıt injacpa Dios y juıt injacpa jem Cordero y jem
imozoyaj icuyoxayajpa.

Jeeyaj iixayyajpa jem
iQmi iámooyi. Cada
tımı́tım jem imozo
jaycámayñeta jem
iQmi iñı́yi
iwiñpacyucmı́.



Jesic ánix jém caaneyajwïp teñyay Dios iwiñjom. Íttim
jém mijpic y jém xutupic. Áñáyta jém libroyaj. Áñáyta_{tim}
jém tungac libro, jém libro de la vida. Cada tumtum jém
caaneyajwïp cïpiñyajtap juuts jaycámnetá librojom
juuts iwatneyaj cuando vivo. Jem_{tim}
cotyajtap itumpiy jém pixiñtam
jém dápic i iñiyi jém librojom
ju_t accámneyajta jém
ipictsonpáppic jém
vida jém dápic
cuyajpa.

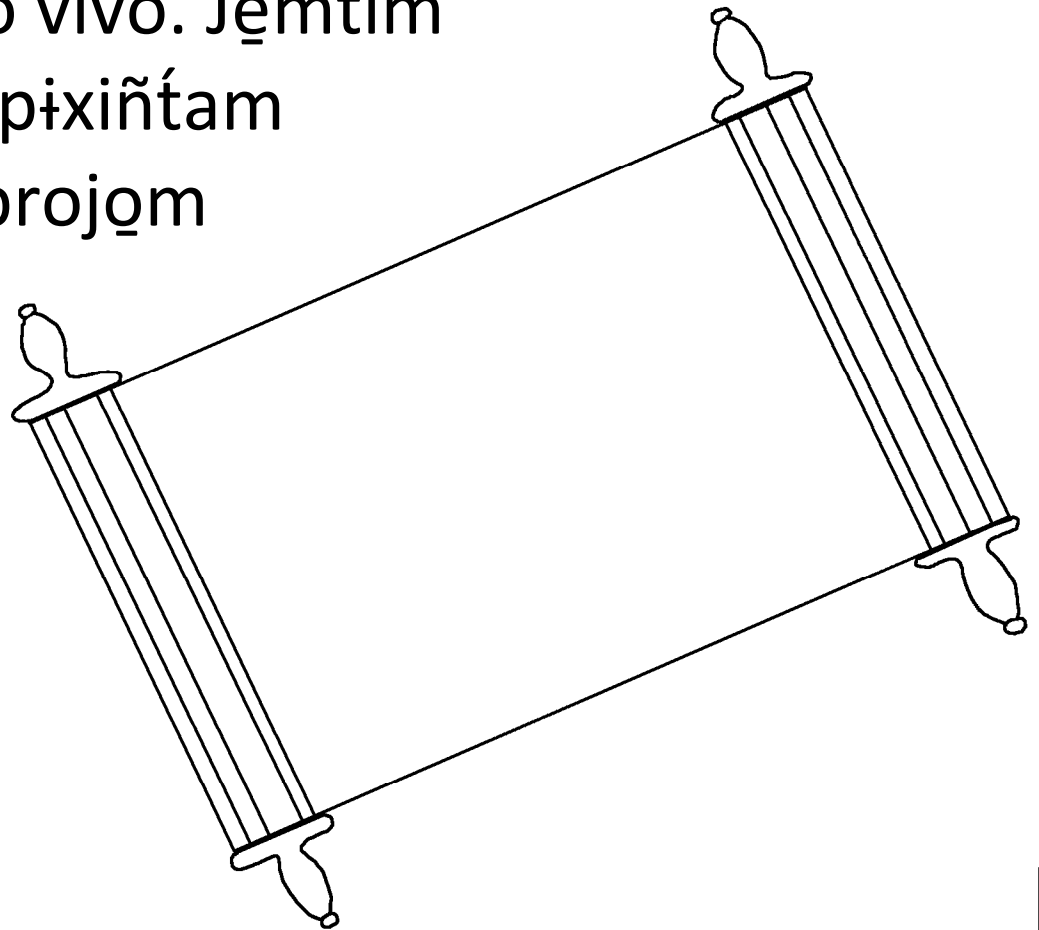

Jém Dios iAnama y jém Cordero iyomo, jém
aṅcoomíyoypaap, nĩmpa: iMiñĩ! Jém imatonyaajpaap
yĩp aṅmaṭi nĩmyajpaṭim: iMiñĩ! Wĩ iga míñiñ jém
níctitsnewĩp. Jém iwĩanjamwĩp, wĩ iga iuguiñ jém nĩ
jém tachiipáppic vida. Āa tamáychiiba Dios, tasajĩpa.



'Dios tsam ítoypa ítumpiy jém p̄ixiñtam
jém ítyajwiip ȳip naxyucmi. Jeeyucmi
ijíc iga accaata jém t̄umpic iM̄anic
iga ítumpiy jém icupicneyajwiip
jém Dios iM̄anic dá togoypa,
mas ip̄ictsonpa jém
vida jém dápic
cuyajpa.



ROMANOS 3:23

Ítumpiy p̄ixiñ táncaiyaj. Dá j núcpa juť ít Dios porque dá j iwatne juuts je ixunpa.

ROMANOS 6:23

Ítumpiy jém imalwatyajpáppic ipictsonpa juuts tum coñwiyoooyi iga nicpa jém infierno. Pero Dios tachiiba jém vida jém dápic cuyajpa juuts tum xaja cuando tamichap jém tánQmi Jesucristo.

HEBREOS 9:27

Dios ichac iga tunçiy caaba ítumpiy jém p̄ixiñtam y ocmi çiipin̄tap, chiit̄ap castigo jém malopic.



EFESIOS 2:8,9

Dios tsam tayaachanjampa, jeeyucmi miciaacputta porque incupicne iga Dios wiaap miyoxpat. Da inyaac miniciaacputta, pero Dios michi tum xaja. Da i wiaap iwawat iga naciaacputtap iyaac, iga da i wiaap inicujipta iyaac.

ROMANOS 10:9,10

Siiga ininmadaypa jem pixiñtam iga jem Cristo mich inmi y siiga incupicpa inanamajom iga Dios icpis jem Cristo de jut it jem caaneyajwip, jesic Dios miciaacputpa. Porque tancupicpa jem Cristo tananamajom iga Dios tawitsagayin jem tantanca. Tananmadaypa jem pixiñtam iga tancupicpa jem Cristo iga taciaapudin Dios.



SAN JUAN 3:16,17

'Dios tsam itoypa itumpiy jem pixiñtam jem ityajwiip yip naxyucmi. Jeeyucmi ijic iga accaata jem tumpic iManic iga itumpiy jem icupicneyajwiip jem Dios iManic da togoypa, mas ipictsonpa jem vida jem dapic cuyajpa. Porque Dios da icutsat iManic yip naxyucmi iga ichiiba castigo jem pixiñtam. Icutsat iManic iga iciacputyajiñ itumpiy jem ityajwiip icuwiti yip naxyucmi.

1 JUAN 5:11-13

Tacjodónaneta iga Dios tachiiñetámum jem vida jem dapic cuyajpa, yip vida iniit jem Dios iManic. Jem iniitwiip jem iManic, iniitum jem vida. Pero jem dapic inij jem Dios iManic, je da inij jem vida. Manjáyáypa mimichtam jem incupicnetanjwiip jem Dios iManic ñiyi iga ññuntawijodon iga impictsonneta jem vida jem dapic cuyajpa.



SAN JUAN 14; 2 CORINTIOS 5; APOCALIPSIS 4, 21, 22

Storyline by: Edward D. Hughes

Illustrated by: Lazarus
and Alastair Paterson

Adapted by: Sarah S.

Popoluca, Highland NT (poi) © 1977, 1997, Wycliffe Bible
Translators, Inc. All rights reserved.

<https://live.bible.is/bible/POIWBT/MAT/1>

©2026 Bible for Children, Inc.

www.M1914.org

www.bibleforchildren.org

