

Bibilo I mbayev or gberen

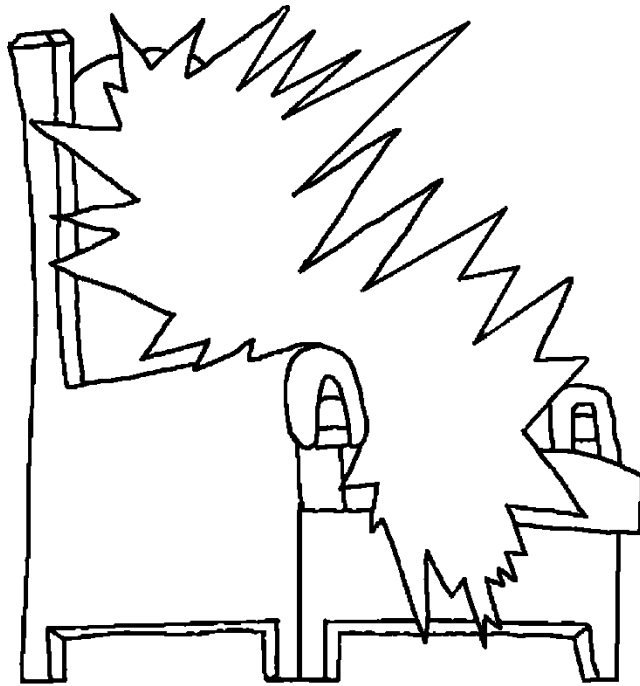

Ya u Aondo
ka tartor u
engem



or ngeren: Edward Hughes

sha zwau: Lazarus
Alastair Paterson

ngohol: Sarah S.

or geman: www.christian-translation.com

or gberen: Bible for Children
www.M1914.org

©2021 Bible for Children, Inc.

U faityo u ngeren takeda ne man gberen u er u lu teen atee gayo.



Mtse u yesu sha won cii yo aor mbahenev kwagh u tartor ayila er ya u terem ashi akaa er ayough ngee ker ukehe tartoa kehe hembra hanya u shin tar me.

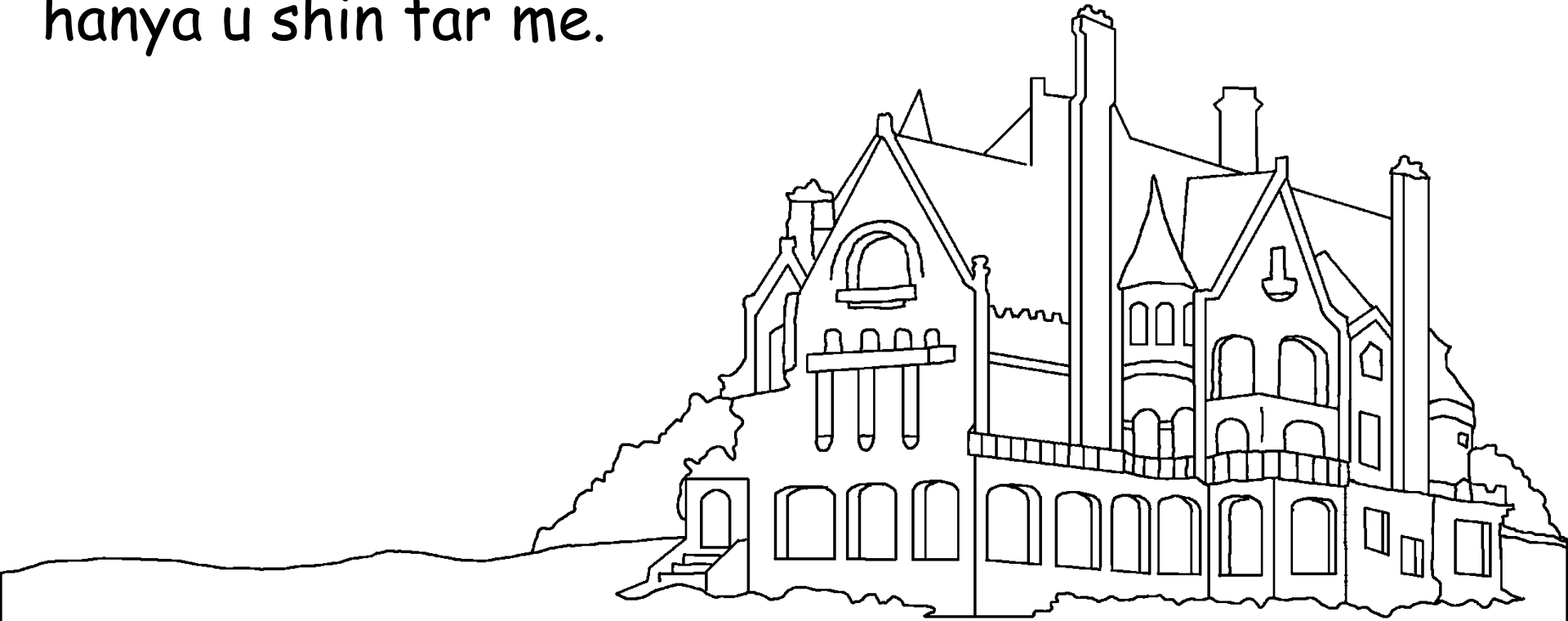

Yesu kaa mngu yemen u za soron ne ijiir me hide
man me va yem a vene ye ayem shien u ander shin
mbakpenev la mba henev nenge er alu kondun yo
abeenngohol un sha ash eave ve.

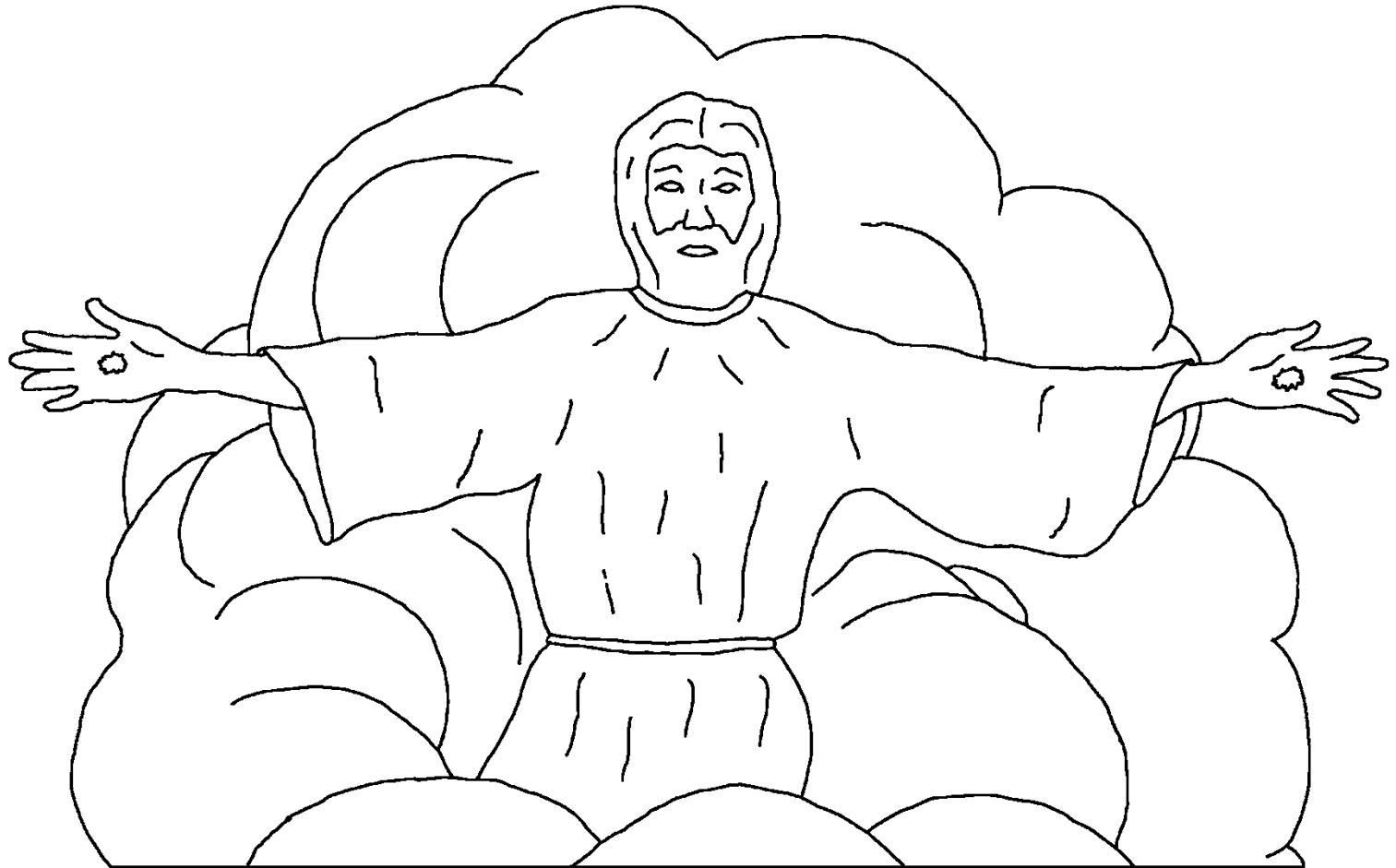

Zan zan je mbakristu mba
umbur tyende zwa I yesu kaa
er una hide ava kua ave la kpa
mba kristu mba ve kpe mhir
na ye bibilo kaa er vea yem
jighrii sha ikum I yesu.

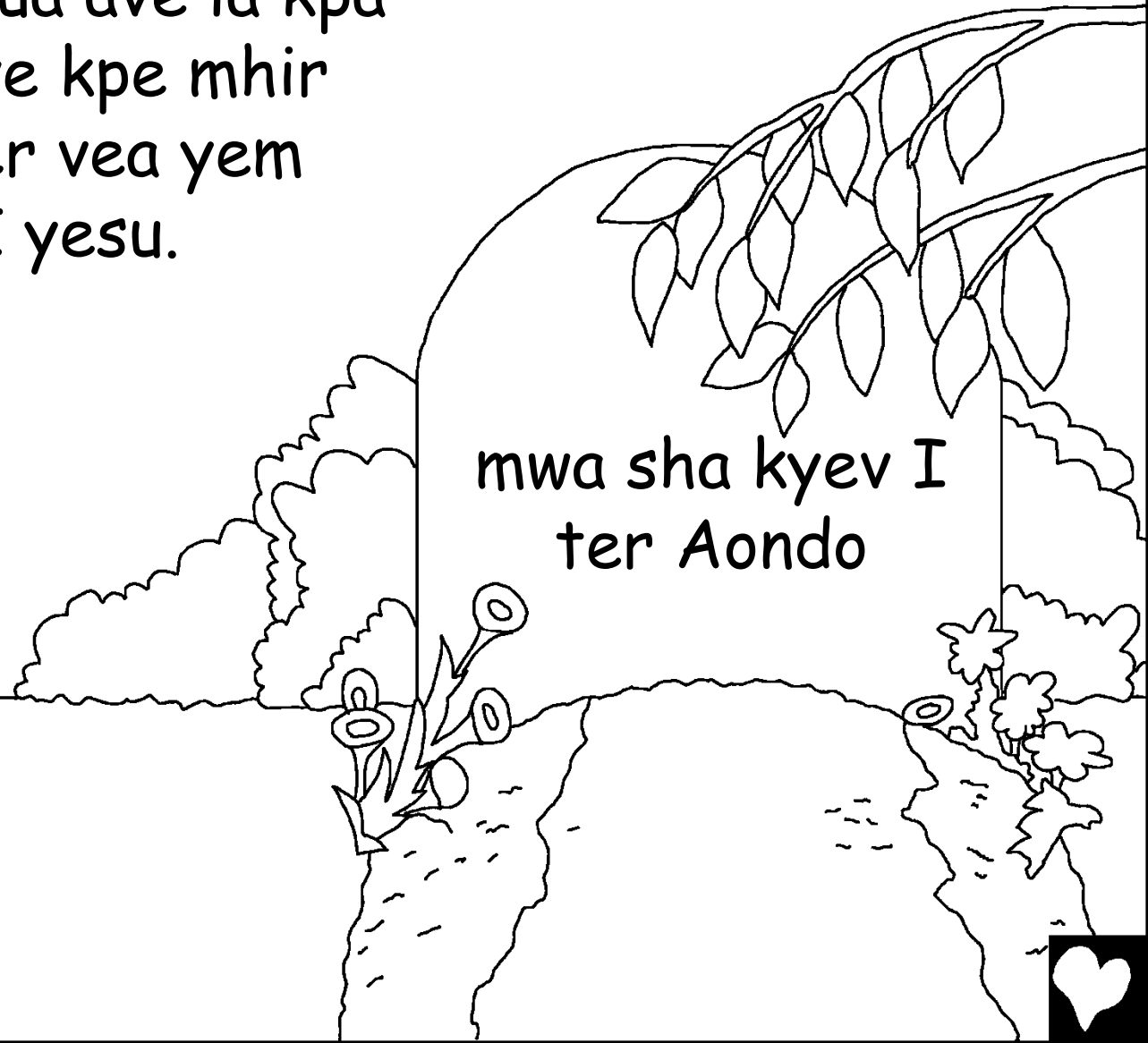

mwa sha kyev I
ter Aondo



Mpase taketa u masejime ken bibilo or se kwagh u tartor jir. Kwagh cier yol yo Aondo er u er ka ya na Aondo ngu hanma vegher. Kpa ikonugh n aka tartor.

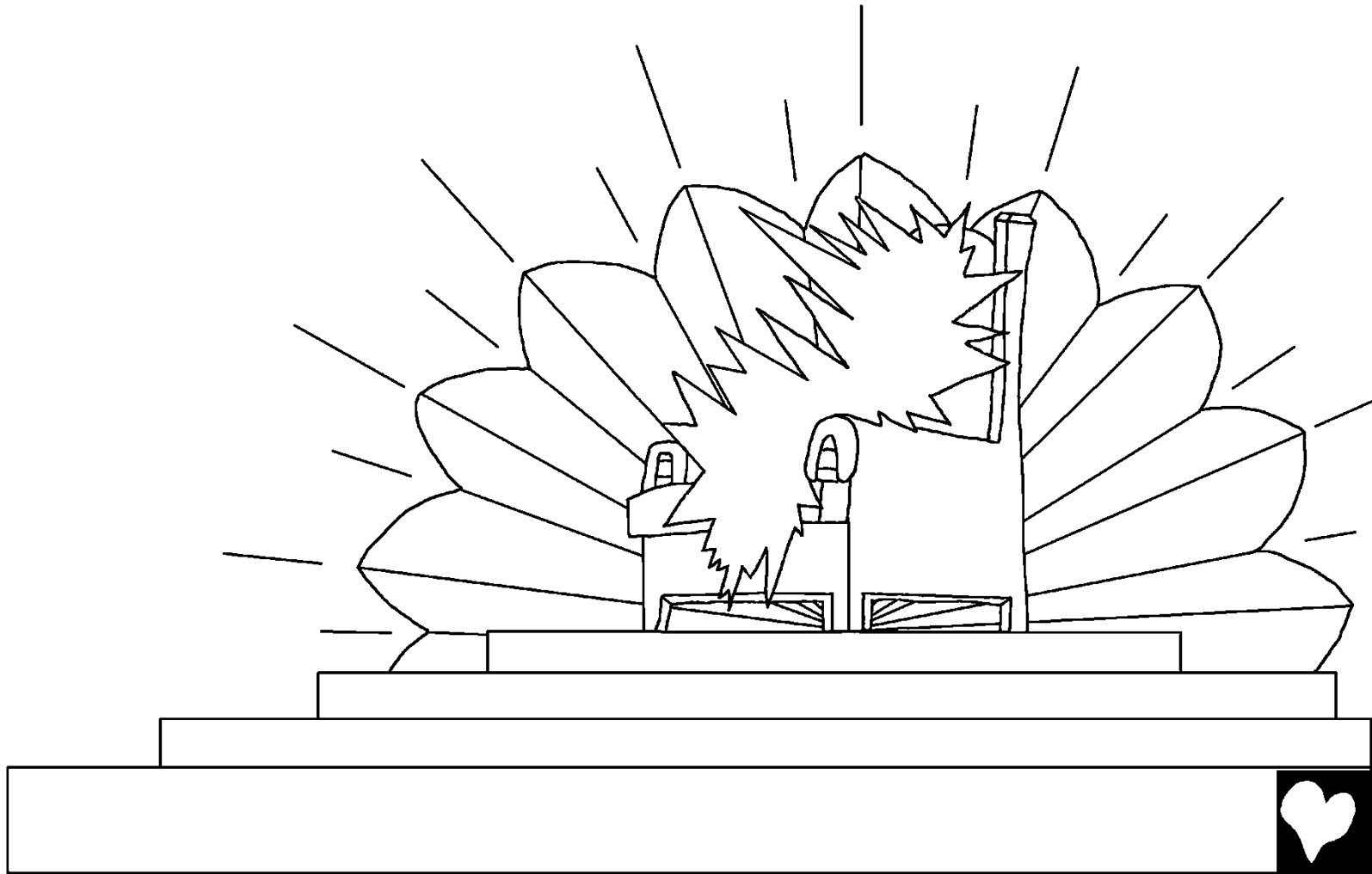

Mbatyomov hanma kwagh sha
tartor yo awuese Aondo ior
mba aondo mba ve kpe cii vea
yem sha tartor veal u wan
atsam a wuese aondo.

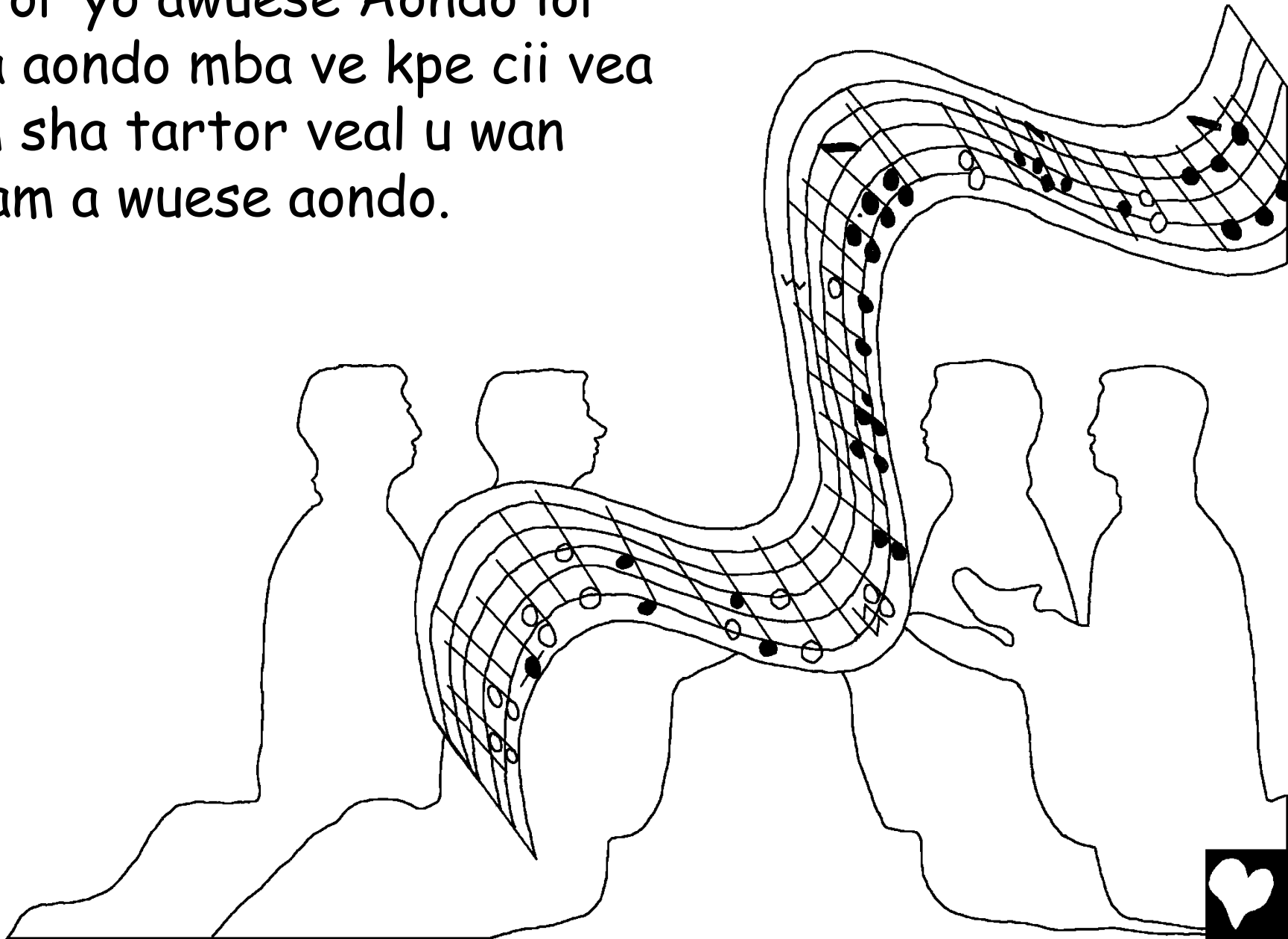

Heen ka atsam a ver lu wuese aondo ve wa icam ihe
ve vekaa er we ukuma ungohol ruamambera bughun
akav ana gadia I songo u man u
yam Aondo ior sha awambe a ou
ken hanma nongo man hanma zwa
man hanma nongoior man hanma
ikurior uer ve ve
hingir tartor
man upristi sha
ciu u Aondo
wase. Tyough
itian ivur
utaan kar
unyiin.

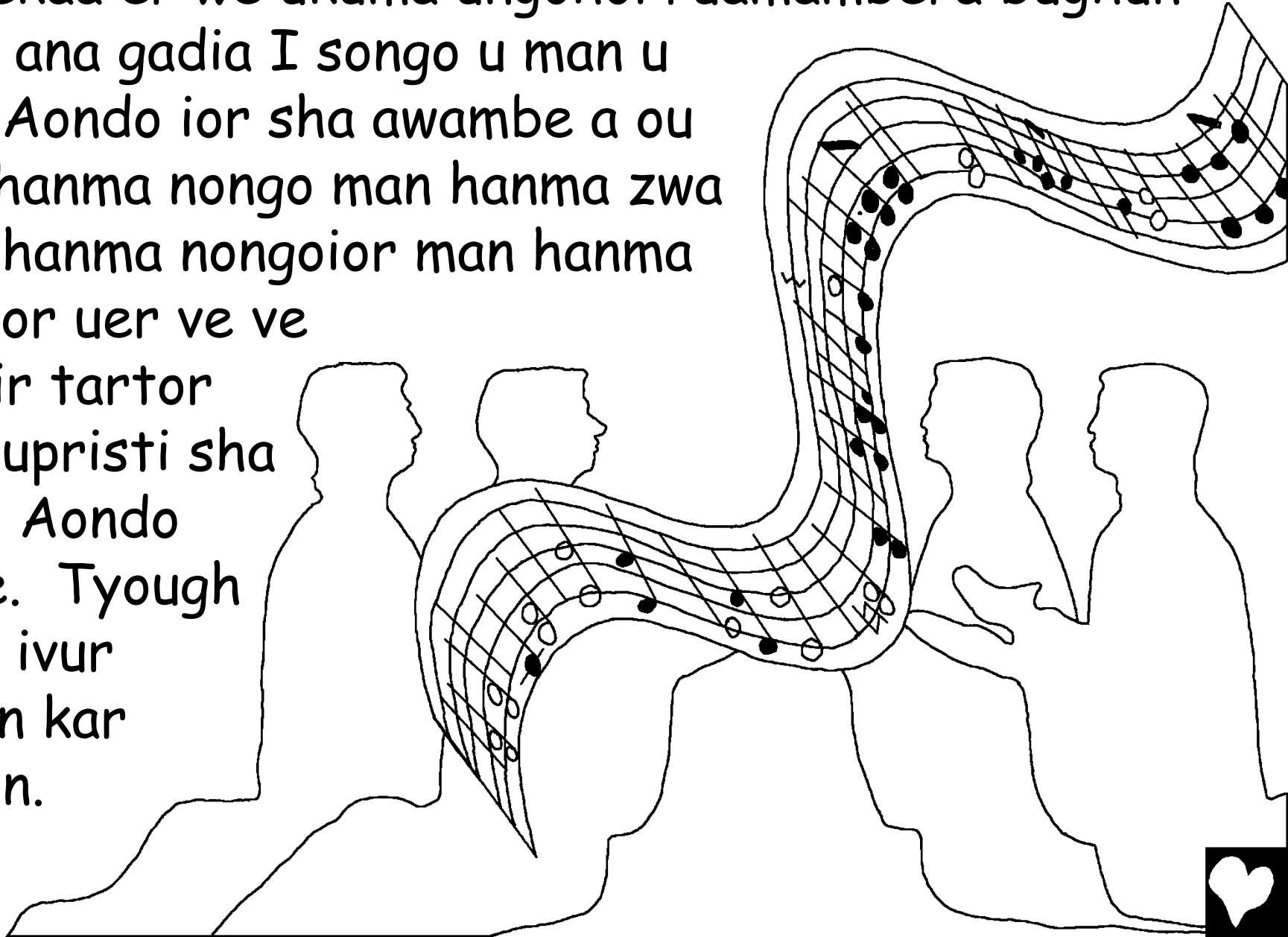

Tyough ki bibilo ki mase jime ki or kwagh u
yerusalemka ijiir I vesen kpekpe na uken won kpa
kehe imar sha awen yafeta man zanaria engem ngu
a ugirgar ngu u zenge mba mto.

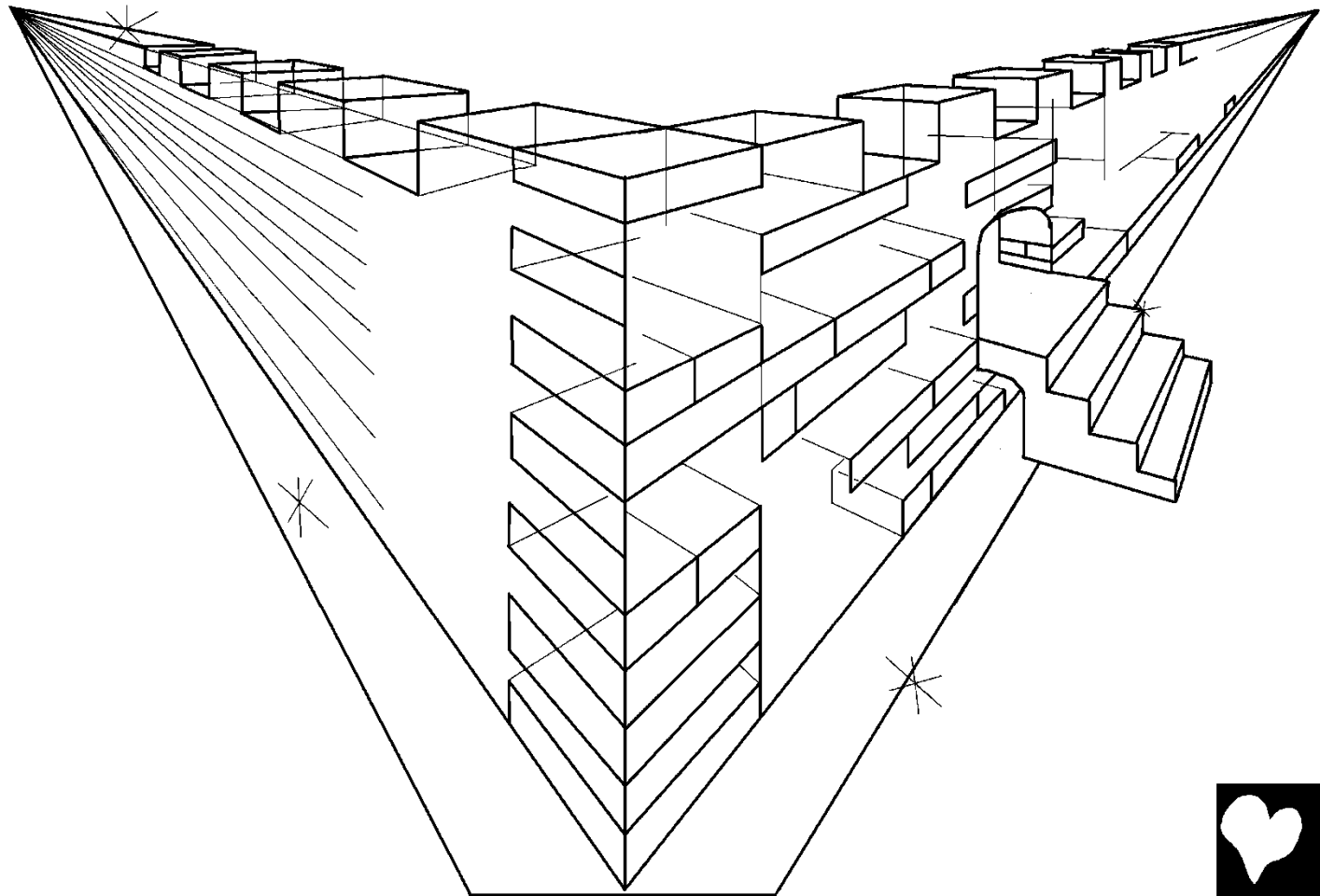

Ukpar nav kpa mba kesan ga va se za nenge tartor
engem ken ato hembra ken ato I ma aka myou ma
taver ishe er ka ujigi igbenda kpaa engem.

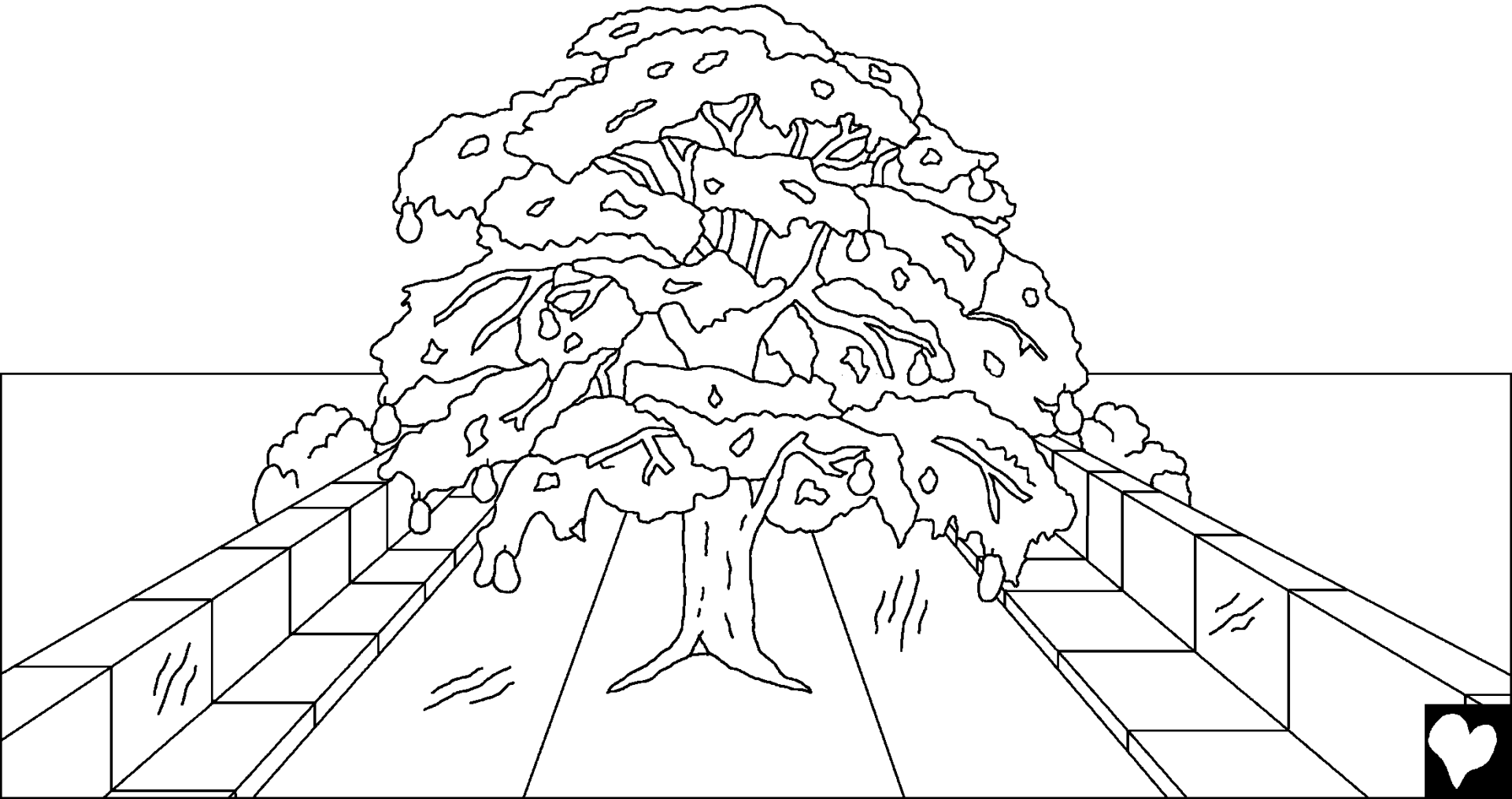

War u vesen u ma u tsoron kpa uva hen aondo war la
ka kon uma u tsoron man izua amin ken sule u eden
ka kon tsoron ume ikwe pue kar ihiar ika I kon la ka
uma utsoron.

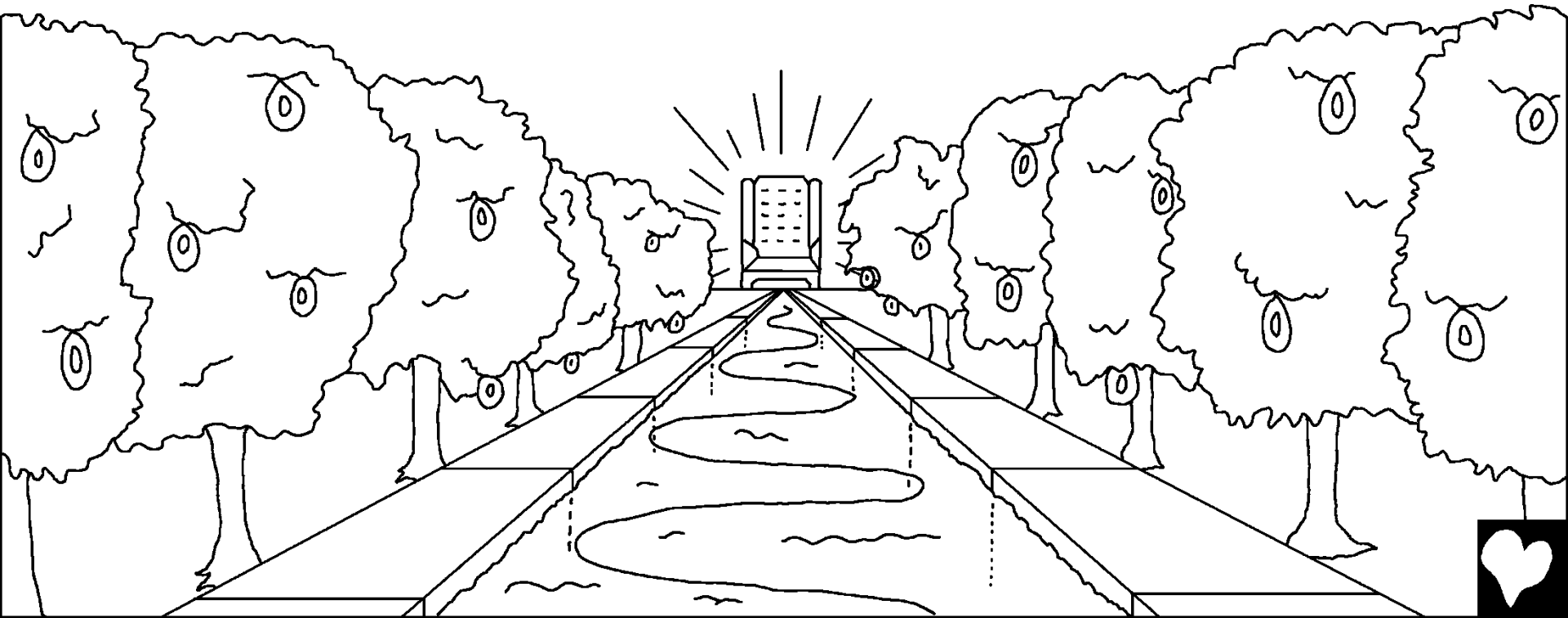

Iyange man wer mba sha tartor utan iwanger ga
Aondo yol n aka iwanger I tartortugh mbu ga.

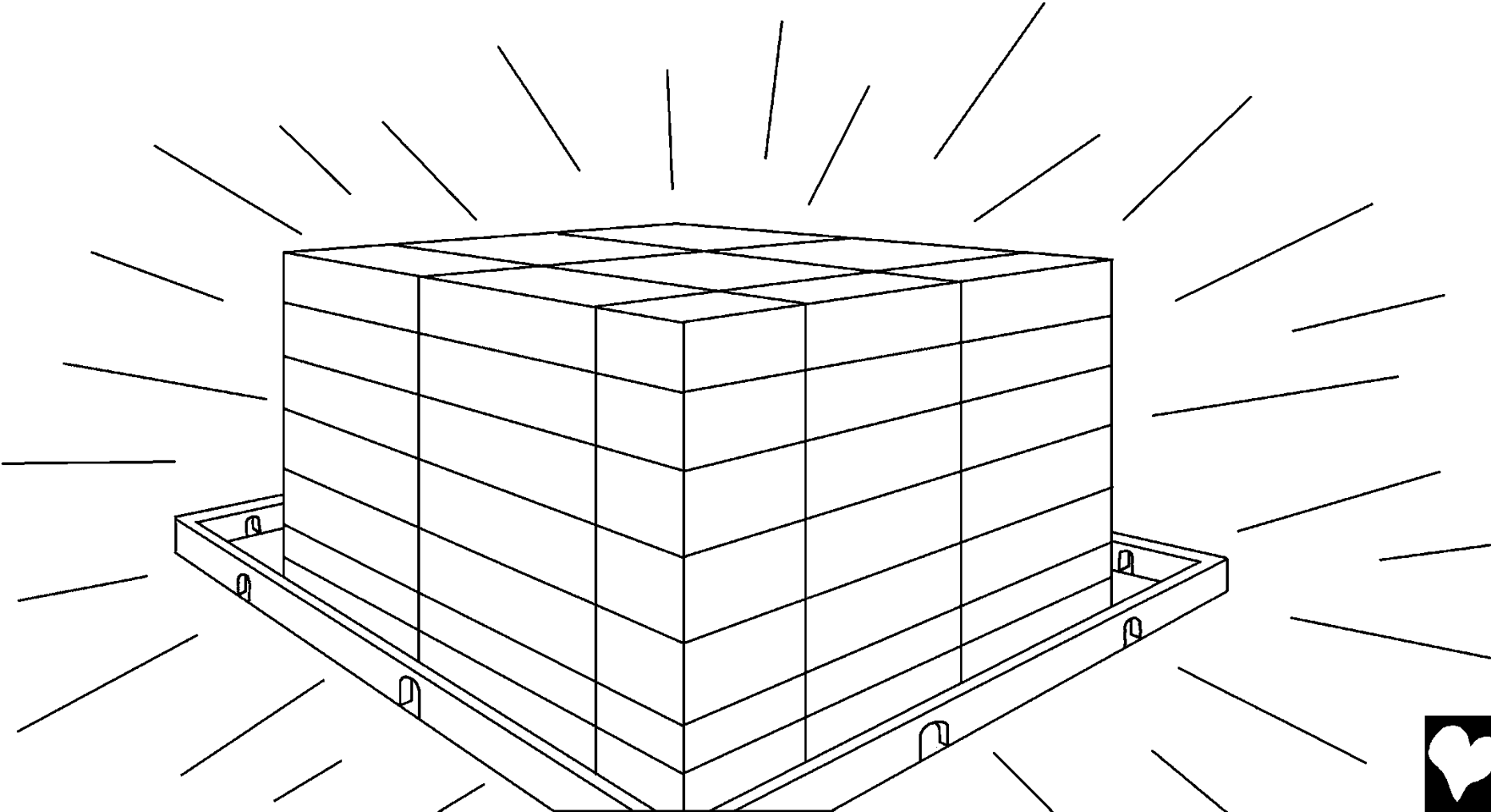

Imyam I sha tartor kpa ngi kposo mba ijende anyam
maniyongo mba ye toho kwagh mom begha kpa ye
kwagh mom a bua aondo kaa er mom kpa una tim
ugen ga.

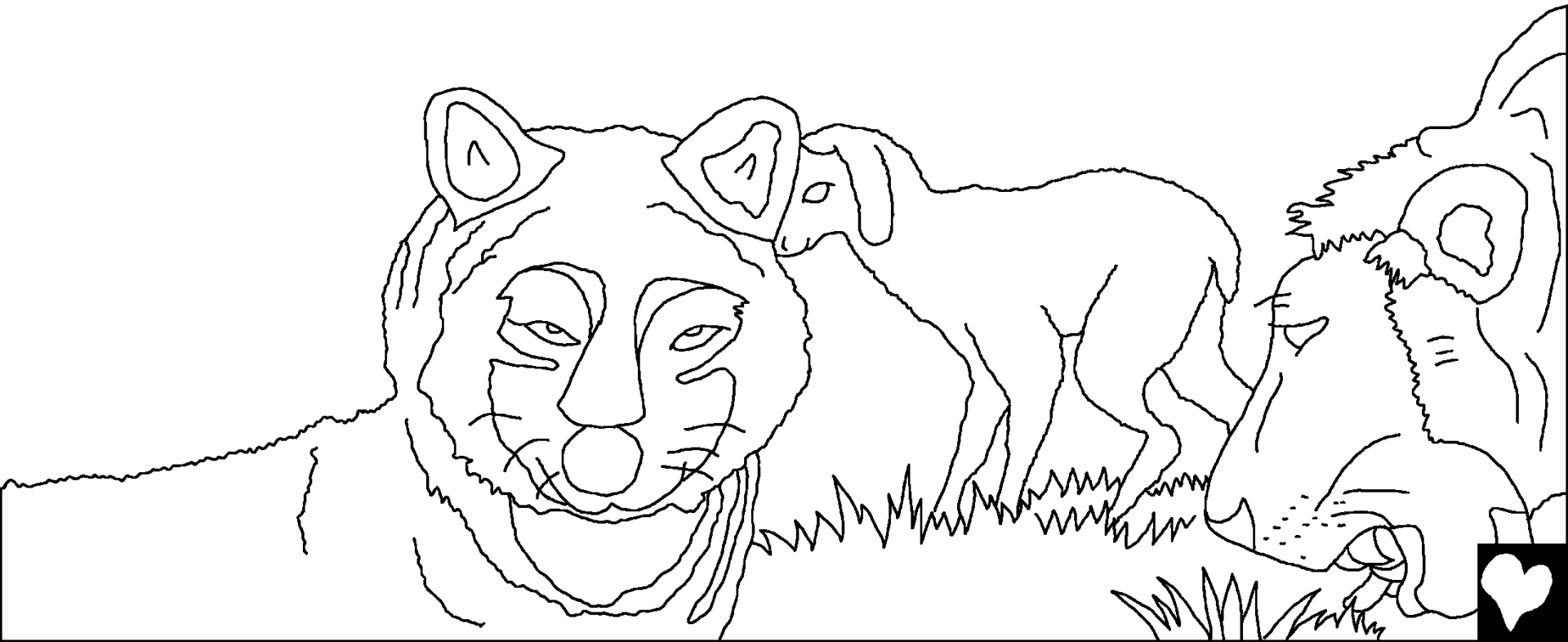

Er se nenge yo
akaa saa sha
tartor shima vihin
ngi ga num nongun
ga iko iwan yol
yough ngi ga hunda
wuhen ga ormbaiv
ngu ga or a ie ngu
ga or wuan or ngu
ga ifer or ngu ga.



Sha tar usha yo mlia
ma ga shie gen yo ior
ka ve vaa sha ciu
kwagh tseren kpa sha
tartor yo Aondo una
ese se mliam.



Ku ngu ga ior mba Aondo veal u a na imongo ijugwen
ngi ga mlia ma vaan ga mnyion ngu ga angev mbu ga
hanma or sha tartor yo nan saan gbem.



Bee cii yo tartor ngu sha ciu mbayev nomso man
mba kasev mbavesen kpa a mba ve ne yesu jighjigh
ye ka oryiman vey o shiv e eren ishima na yo. Sha yo
taketa ngu u iyilan er taketa u uma uiv a ti ufa ati
aior a lu kereior mba v ever ishima
sha yesu iti yough ngi kere.

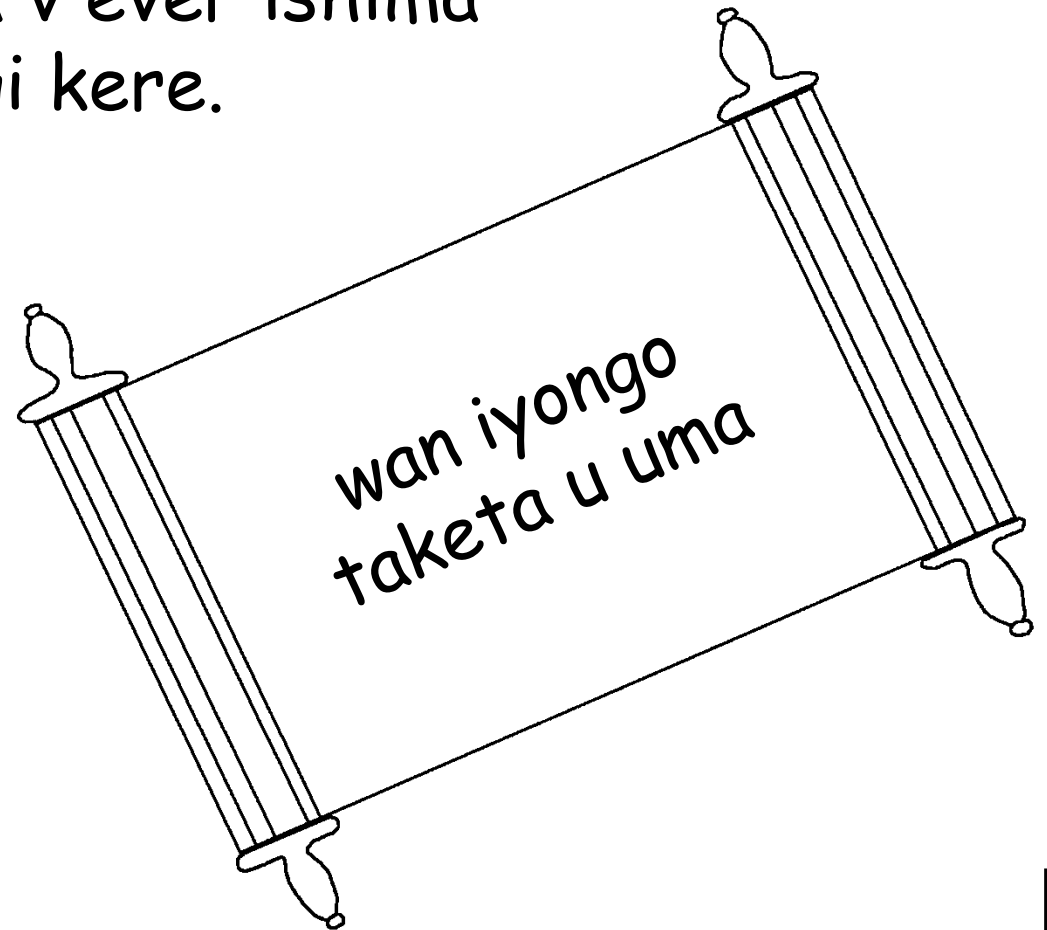

Mkur u bibilo sha kwagh u tartor yo ka mlehe
jijigi man kwase he va ugwa va or u imura iker
nan kpa nanava or unan ugwa kpa nana va
ma mngerem ma uma utsoron.

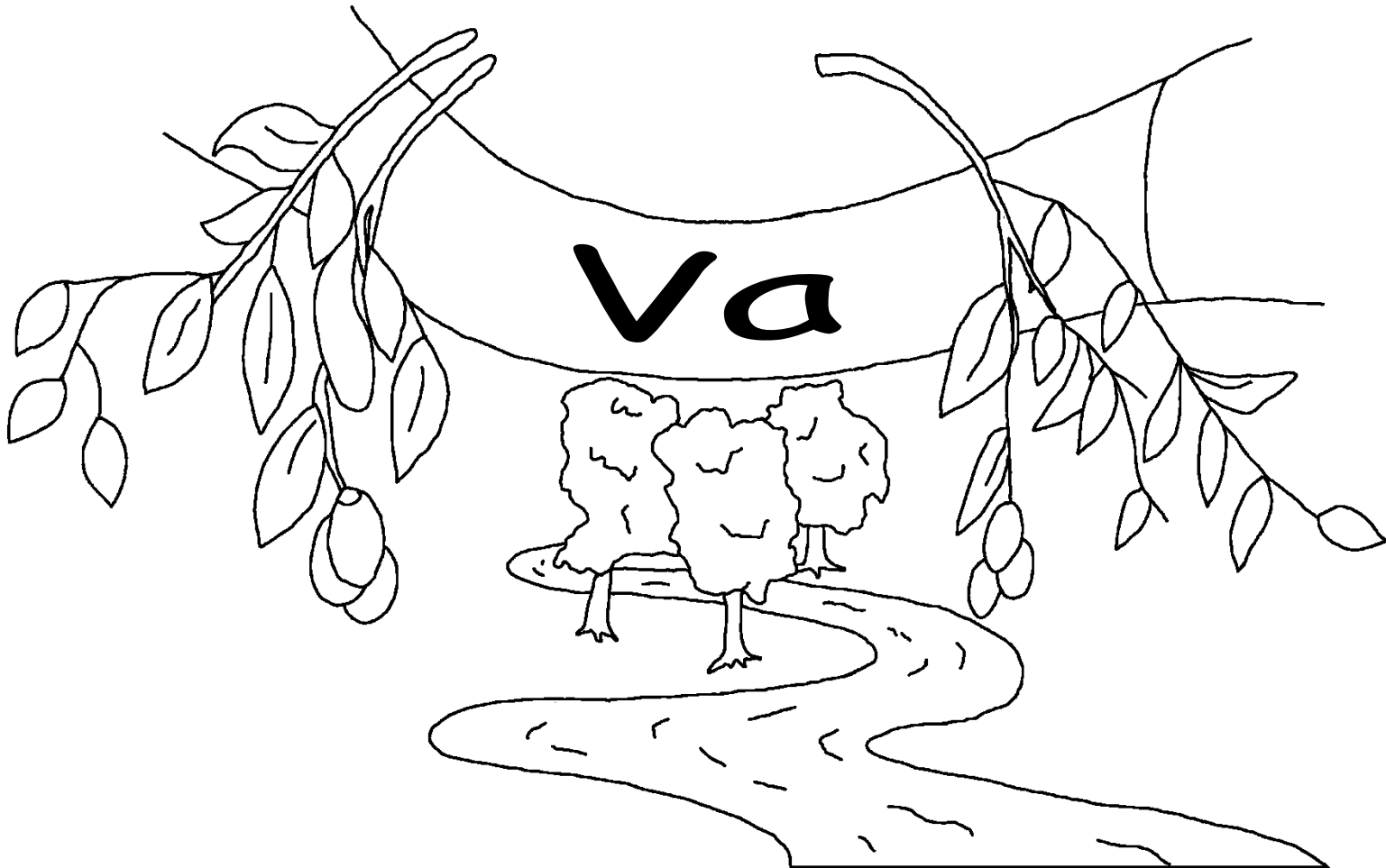

Ya u Aondo ka tartor u engem

Kwagh oron usha zwa u aondo ka bibilo

i zua amin

Yohane tyough pue kar unyiin; mbakorinte
usha uhar tyough itian;mpase tyough inyiin;
kundu kar mom; man kundu kar uhar.

“Kwagh oron wough ne iwanger.” Upasalami
deri mom man pue kar u taan kar unyiin



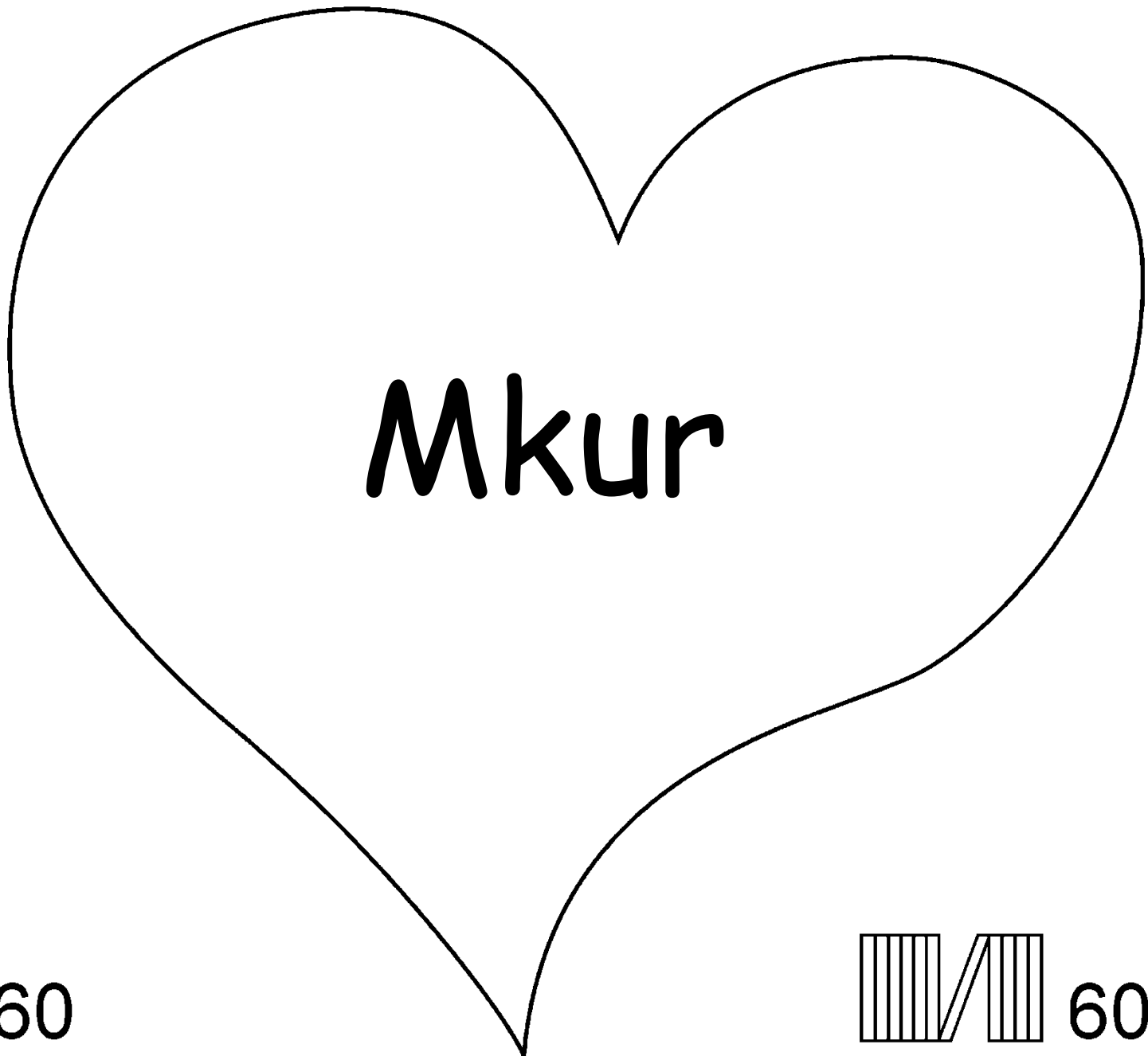

Mkur

| 60

||||| 60



Kwagh orun u bibilo a or se sha akaa
kpilighyol a Aondo aer avese shi a soo ye se fa un la.

Aondo fa se a kaa a vihin a ayila a ye ishoribo. Man injar I
shoribo yo ka ku, kpa Aondo soo se kpishi nahan ana wan u
mom, Yesu ava kpe sha terankon shi itsaha un sha ciu
ishoribo yase. Kpa yesu hide uma man ayem sha tartor,
hanma or ne un jighjigh nana zamber sha mde u asorabo
ngue angee a eren hanma kwagh una lu awe hengen
man we kpaa ula ken ana kpem shawon.

Aluer una na jighjigh we ka kwagh umimi or kwagh ne Aondo
yesu mnau jighjigh u ngu wan u Aondo uhingir or ukpe sha
ciu asorabo am man ungu uma mzamber va ken uma wam man
dem asorabo am sha er me zua a uma uhe hegen er yan igen
me lu awe kpem shawon. Wasem u ugwan kwaghoron
wough man ulun awe er ka wan yo Amen.

Or bibilo man lam vea Aondo hanma iyange yohane
ityough itar ivur pue kar ataratar.

