

[www.BibleForChildren.org](http://www.BibleForChildren.org)

Juan 14

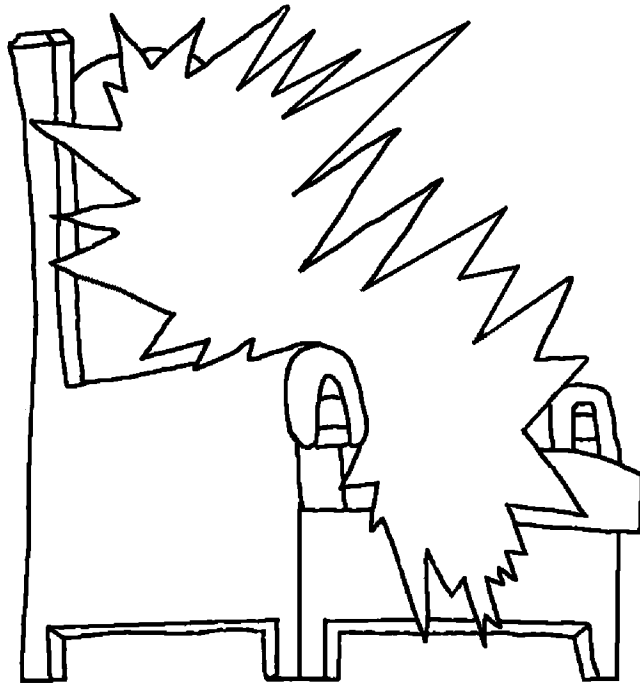

Jesús cāhuanipālh: –Hui'xina'n jātza' catamakchuyī'tit.  
Calīpāhua'ntit Dios ē nā chuntza' quit caquilālīpāhuanui.  
Jā hui'lacha' quinTāta', a'ntza' a'nan lhūhua' pūtahuī'lh.  
Palh jā cahuālh chuntza', xa'iccāhuanin. Ica'nā iccāxui'lī  
pūtahuī'lh jā natahui'la'yā'tit.



A'cxni' na'ica'n ē na'iccāxui'līkō'yācha', na'icmimpala ē  
na'iccālē'nān. Chuntza' jā na'ictahui'la, nā hui'xina'n  
a'ntza' natahui'la'yā'tit.

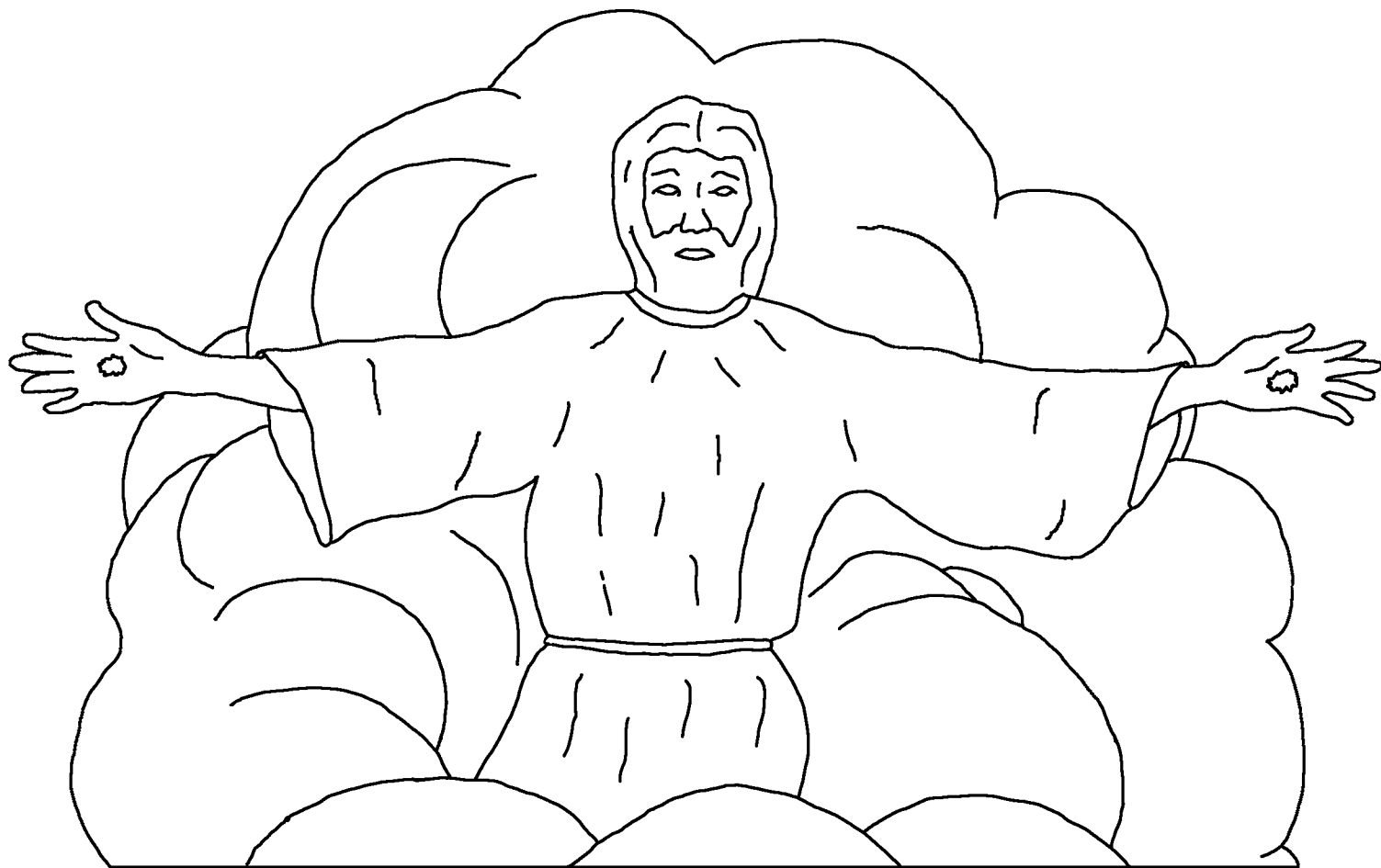

Quit, Juan, mintā'tinca'n hui'xina'n. Quina'n  
tapa'ksīni'yāuj Jesucristo. Quit  
iccātā'pātīni'mā'n ē iccātā'tāyani'yān

hui'xina'n ixpālacata Jesucristo. Quit  
quimacaminca

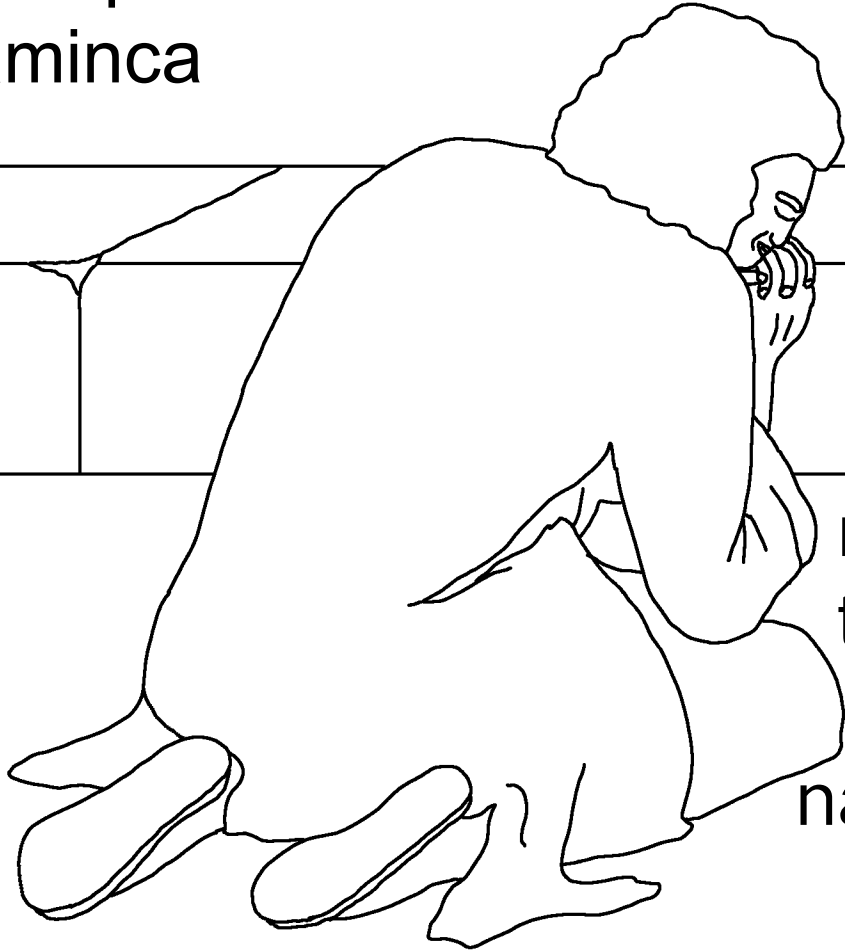

na'ictachoko chī  
tachī'n nac Patmos  
tū pītzuna'j ti'ya't  
na ixpu'nan mar.



Quinchi'pacanī't ixpālacata xa'icmāsu'yumā'lh  
ixtachihuīn Dios ē tū ixlīcāna'  
ixpālacata Jesucristo.



Palaj tunca Espíritu Santo quilē'lh nac a'kapūn. Nac  
a'kapūn ixyālh a'ktin lachtahuī'lh tū ixpūmāpa'ksīn Dios  
ē a'ntza' ixuī'lh chā'tin.

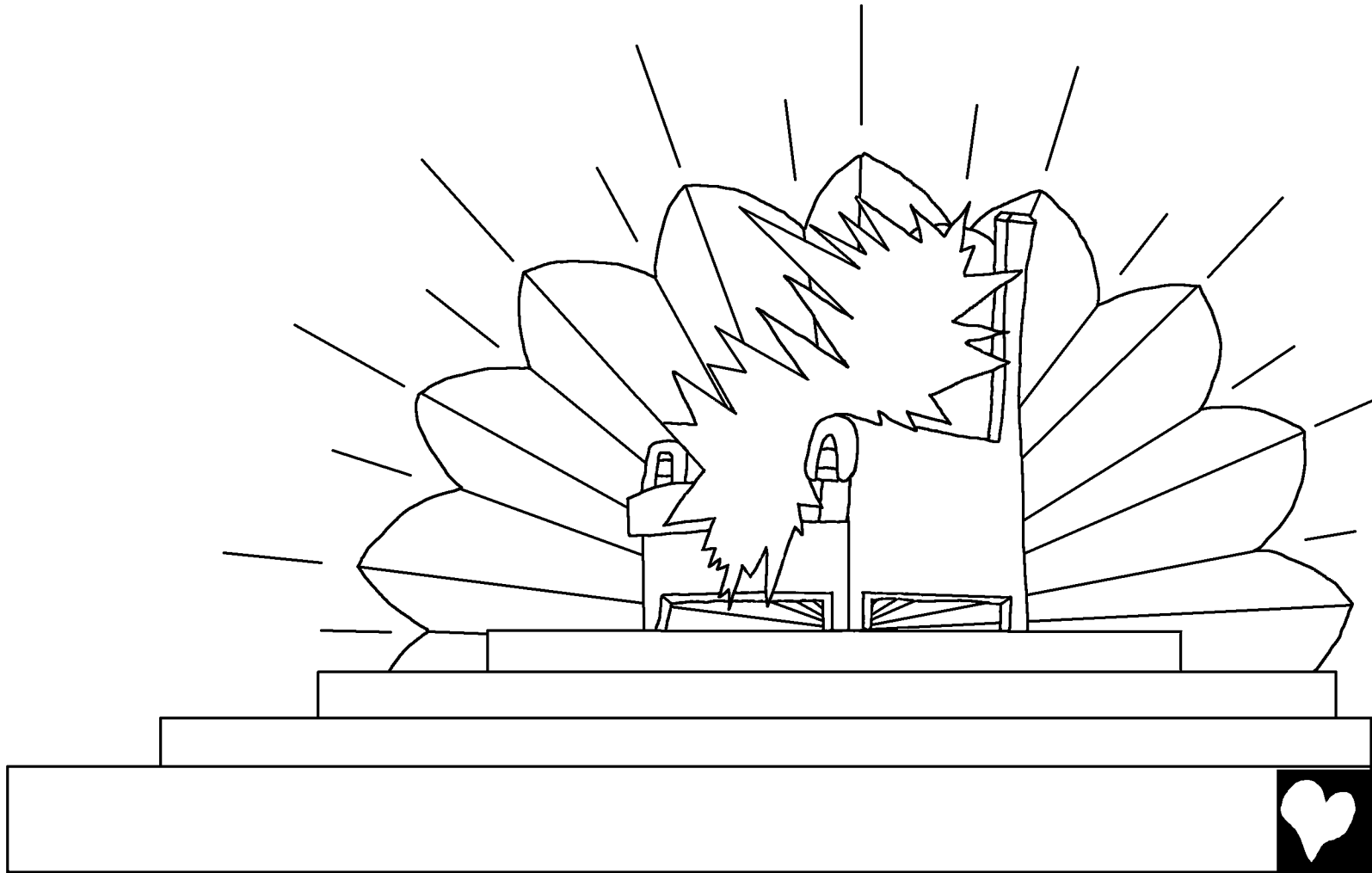

Ē nā ickexmatli chī tachihuīna'nli ixlīpō'ktu tū Dios  
cāmālacatzuculh nac a'kapūn ē nac cā'ti'ya'tna' ē nac  
cā'līnīn ē nac mar. Tahuanli:

Dios tī huī'lh na ixpūmāpa'ksīn ē  
nā Cordero cacālaktaquilhpūtaca  
ē cacālakachi'xcuhuī'ca ē  
cacāmakapāxuīca. Cataka'lhīlh

lhūhua'  
lītlī'hui'qui chī  
pō'ktu  
quilhtamacuj ē  
chī tihua'na'.

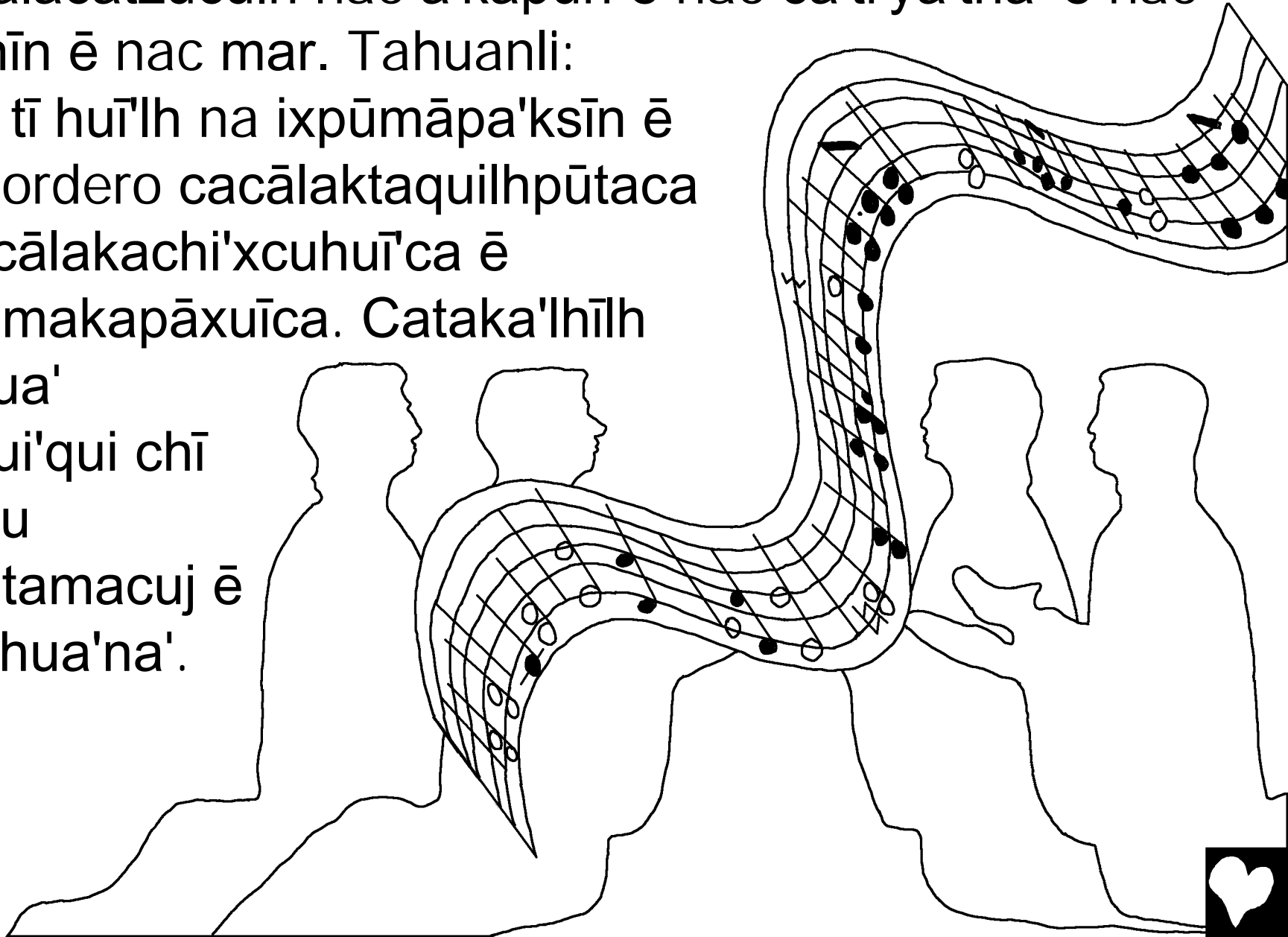

Quit, Juan, iclaktzī'lh xaticua'lanātlahuan  
cā'lacchicni'. Huā'mā' cā'lacchicni' ū'tza' tū xasāsti'  
Jerusalén. Nā iclaktzī'lh chī ixuyjmā'chi nac a'kapūn jā  
hui'lacha' Dios. Cā'lacchicni' tzej ixcāxtlahuacanī't chī  
chā'tin

tasqui'ni'  
tī tzej lhakā'nan  
a'cxni'  
natā'tamakaxtoka  
ṽ'squi'nīni'.

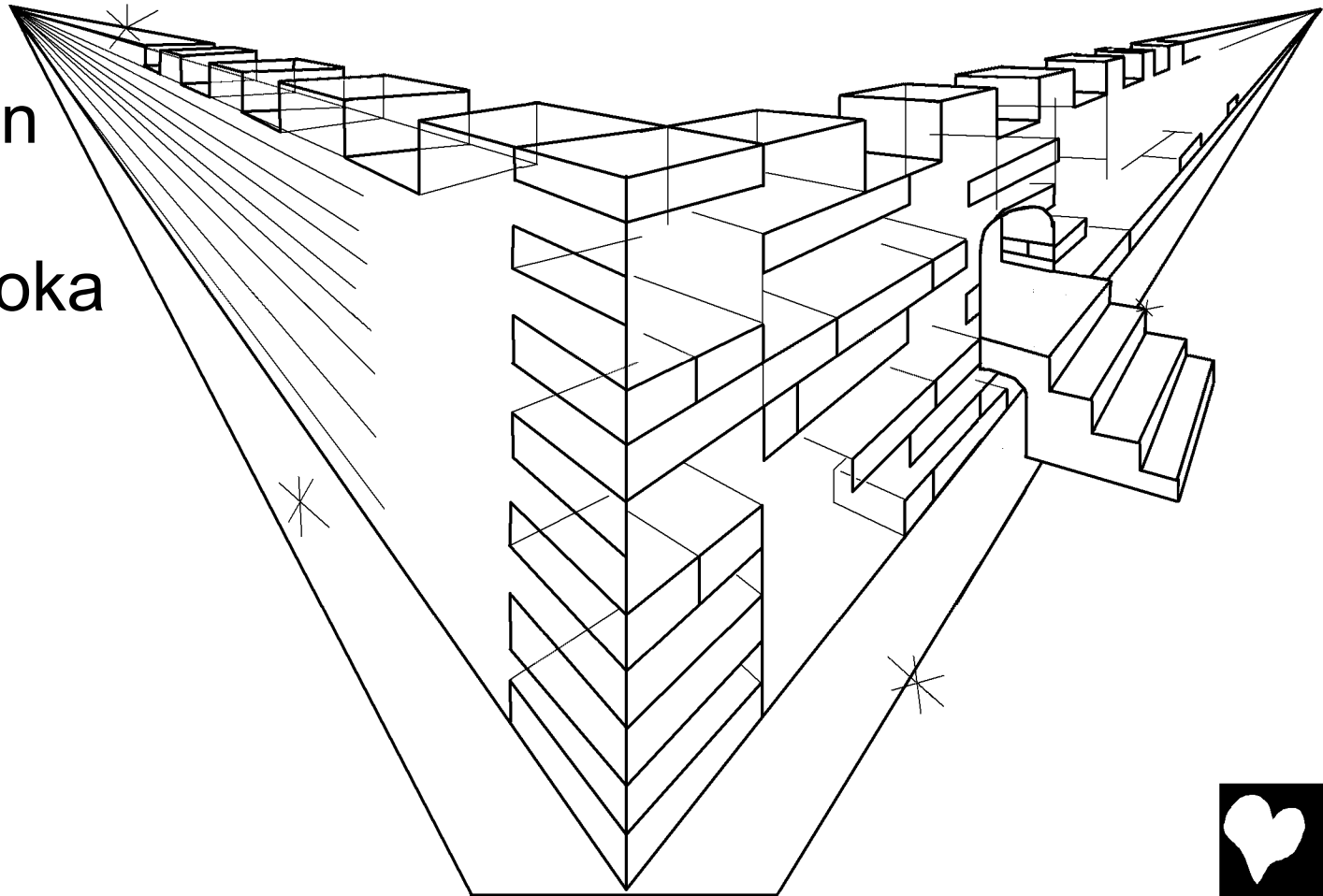

Ā'līstān ickexmatli a'ktin tachihuīn tū mincha' nac  
a'kapūn. Palha' huanli: –Chuhua'j Dios cātā'lahuī'lh  
ixtachi'xcuhuī't. Xlaca'n natalītaxtu ixtachi'xcuhuī't. Ē xla'  
nalītaxtu ixDiosca'n xlaca'n.

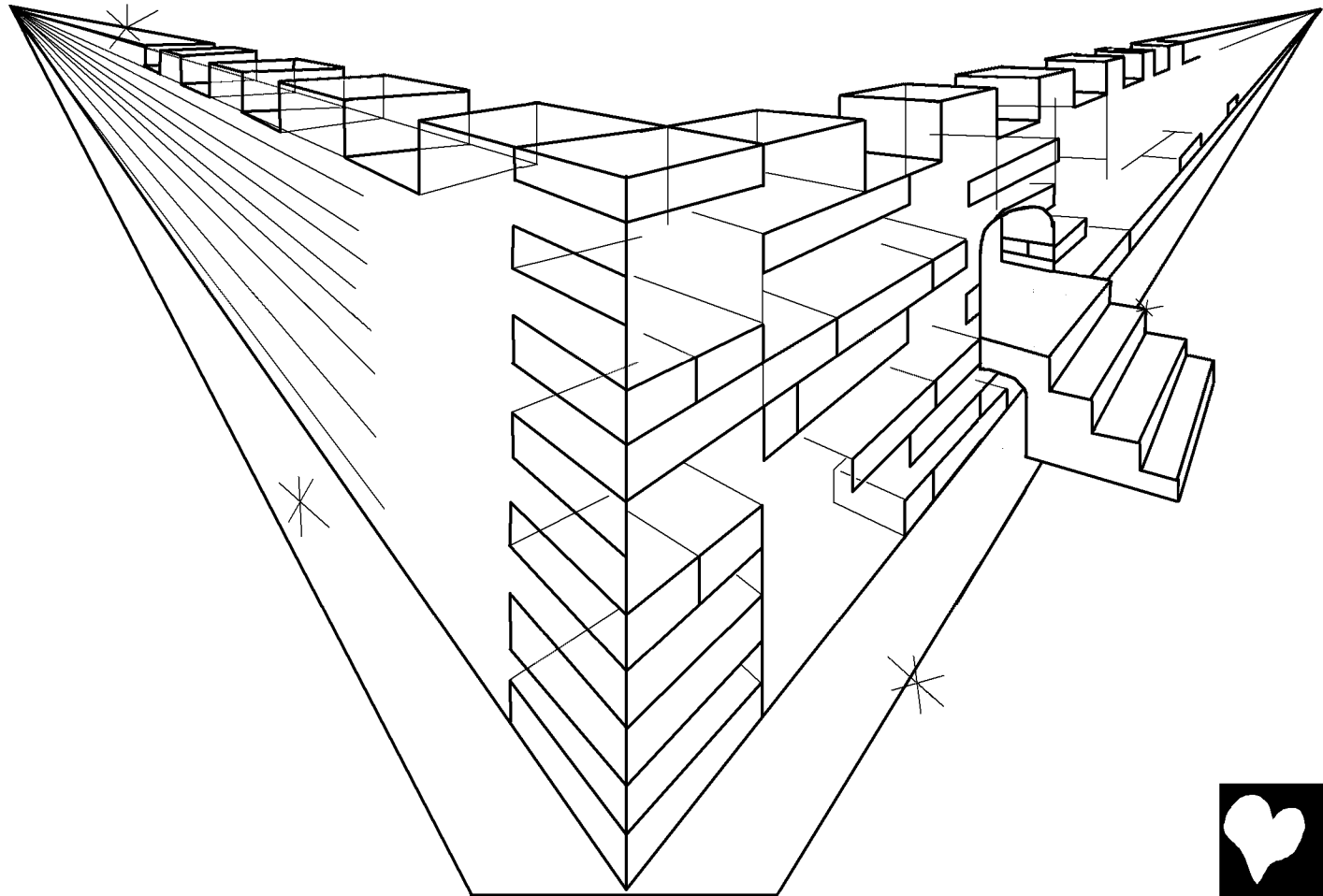

Ā'līstān ángel quimāsu'yuni'lh a'ktin ka'tla' xcān tū  
xatzēhuanī't. Tzamā' xcān ū'tza' tū māsťā' xasāsti'  
latamat. Ka'tla' xcān ixtaxtumā'lh na ixpūmāpa'ksīnca'n  
Dios ē Cordero.



A'ntza' jātza' tī catimaclacasqui'nli chi'chini' nūn  
mālhcu'yu'. Cā'lacchicni' māxkakē Ṭ'xkakana' Dios ē nā  
Ṭ'xkakana' Cordero.

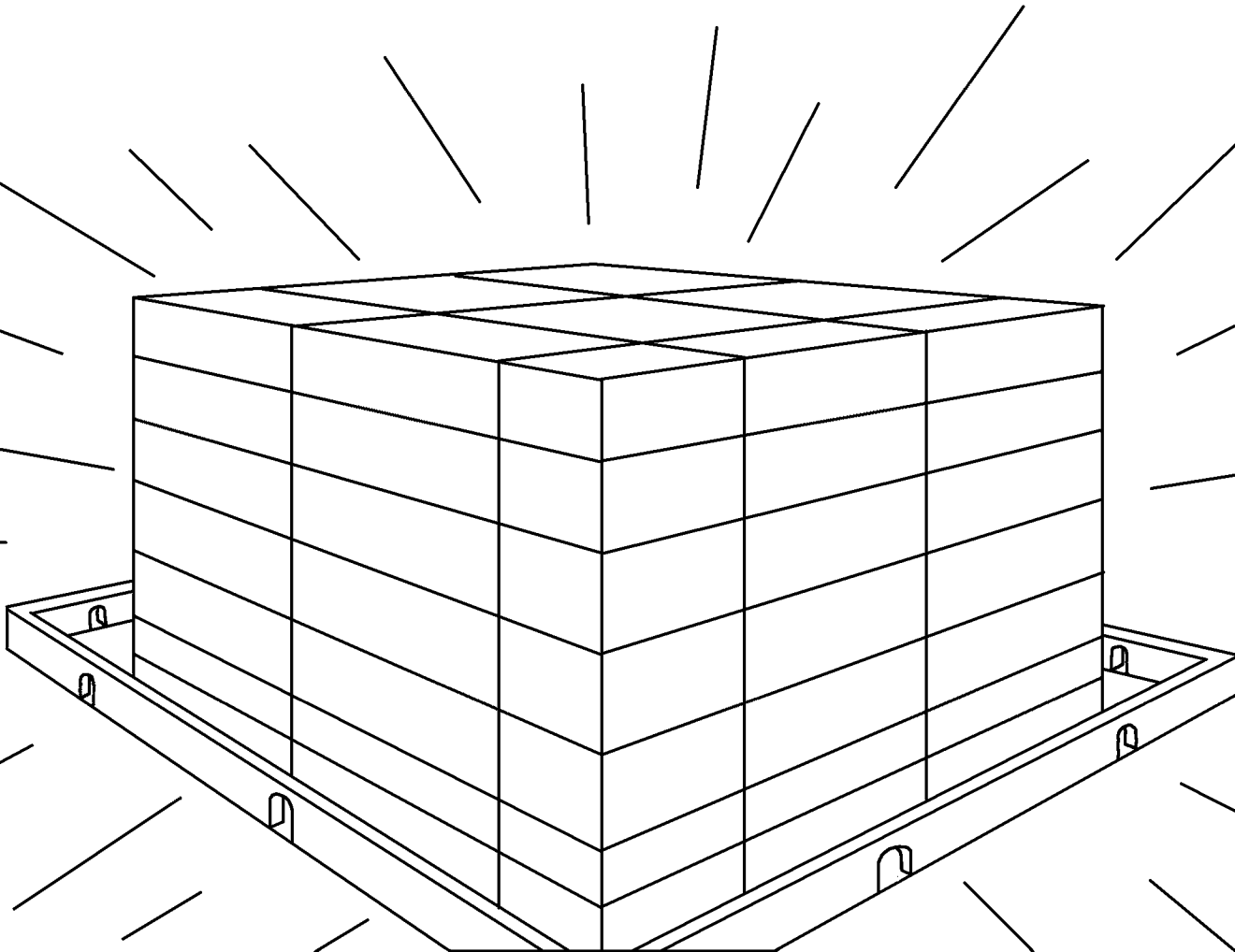

Jā catitanūlh a'ntza' tū jā tze. Jā  
catitatanūlh tī tatlahua tū līmāxana'.  
Jā catitatanūlh tī tahuan tā'ksa'nīn.  
Natatanū a'ntza' xmān tī  
cātzo'kcanī't  
ixtacuhuīni'ca'n na  
ixlibro Cordero tī  
taka'lhī xasāsti'  
ixlatamatca'n.



Dios nacāmāscāquīni'  
ixlakaxta'jatca'n. Jātza'  
catitanīh. Jātza'  
catitalīpuhuanli. Jātza'  
catitacalhuanli. Jātza'  
catitapātīni'nli. Jātza' tū  
caticā'a'nani'lh nūn tū xapūla.



Jā cati'a'nalh a'ntza' tū jā tze ixpālacata a'ntza' huī'lh  
ixpūmāpa'ksīnca'n Dios ē Cordero. Natamakapāxui  
Dios tī tatapa'ksīni'. Cā'lacan natalaktzī'n Dios.  
Nacātankāhui'līcan ixtacuhuīni' Dios tī tatapa'ksīni'.



Iccālaktzī'lh nīnī'n, laka'tla' ē xalacstīn. Xlaca'n  
ixtayāna'lh na ixlacatīn Dios. Cāmālakakē'ca libros.  
Ā'līstān mālakakē'palaca ā'a'ktin libro. Ū'tza' huā'mā'  
libro a'ntza' jā cātzo'kcanī't ixtacuhuīni'ca'n tī taka'lhī  
xasāsti' ixlamatca'n. Cāputzāna'ni'ca  
nīnī'n chuntza' chī ixtalatā'kchokonī't  
chuntza' chī ixtatzo'kni' ixlīpō'ktu tū  
ixtatlahuanī't. Nā cāmacā'nca  
nac cā'macscutnu'  
ixlīpō'ktuca'n tī jā  
ixcātzo'kni'canī't  
ixtacuhuīni'ca'n nac libro  
jā tatzo'kni'  
ixtacuhuīni'ca'n tī taka'lhī  
xasāsti' ixlamatca'n.

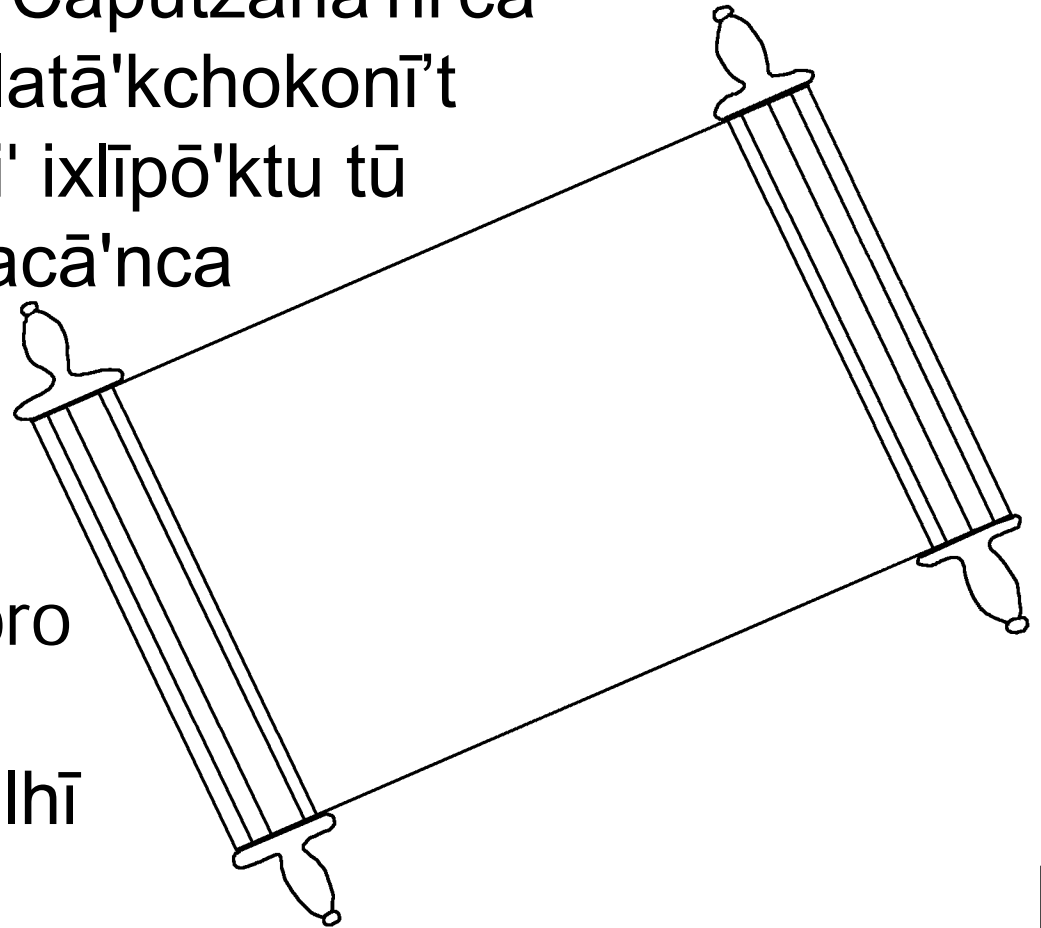

Espíritu Santo ē ixtasqui'ni' Cordero, xluca'n tahuan:

–Cata'ntit. Ixlīpō'ktuca'n tī takexmata catahualh:

–Cata'ntit. Cataminkō'lh ixlīpō'ktuca'n tī takelhpūtī, ē  
catahua'lh xcān tū māstā' xasāsti' latamat.

Cāmaxquī'can chī talakalhu'mān tī tamaktīni'ncu'tun.

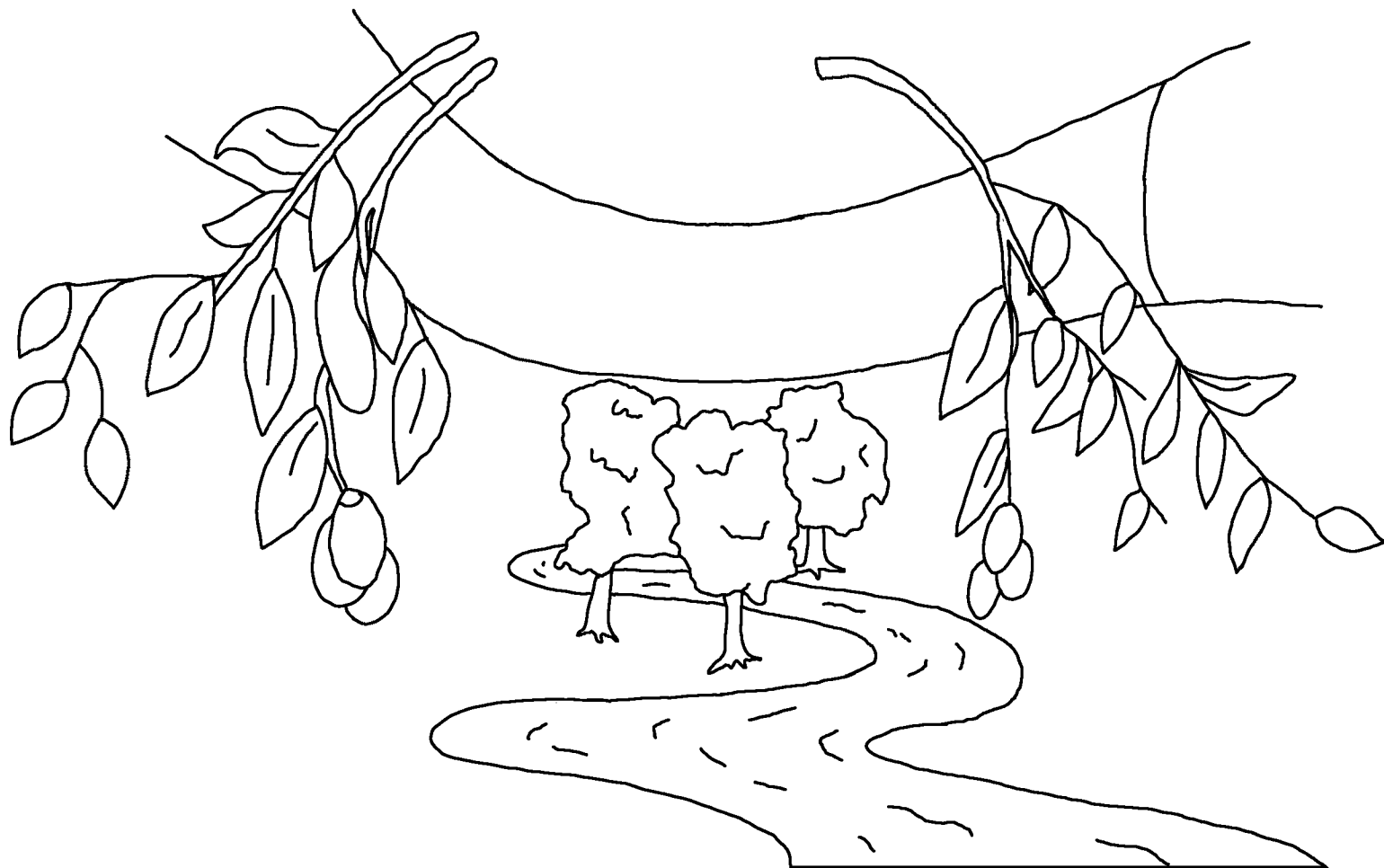

Jesús cāhuanipālh: —Dios cāpāxquī'  
ixlīpō'ktuca'n tachi'xcuhuī't xalanī'n  
nac cā'quilhtamacuj.



Ū'tza' līmāstā'lh tī ixlīmān ī'Ska'ta'  
ē chuntza' tī natalīpāhuan xla', xlaca'n  
jā makstin catitasputli. Nataka'lhī  
xasāsti' ixlamatca'n tū jā  
ka'lhī ixlīsputni'.



Romanos 3:23 Quilīpō'ktuca'n tlahuanī'ta'uj tū jā tze. Nūn  
chā'tin tī līlacatejtin latā'kchoko chuntza'  
chī Dios lacasqui'n.

Romanos 6:23 Xlaca'n tī cāmāpa'ksī tū jā tze, xlaca'n  
natamaktīni'n ixtatlajca'n. Ū'tza' līnīn. Dios  
quincāmaxquī'yān xasāsti' quilatamatca'n tū jā catilakspuṭli.  
Ixlīpō'ktuca'n tī ta'a'ka'ī'ni' quiMāpa'ksīni'ca'n Jesucristo,  
xlaca'n cāmaxquī'can xasāsti' ixlatamatca'n  
tū jā catilakspuṭli.

Hebreos 9:27 Quilīpō'ktuca'n nanīyāuj xmān maktin.  
Ā'līstān Dios naquincākelhasqui'nīyān.



Efesios 2:8,9 Hui'xina'n līpāhua'nā'tit Jesucristo, ē chuntza'  
Dios cāmakapūtaxtūn hui'xina'n xmān ixpālacata  
cālakalhu'manān. Jā tū tlahua'tit hui'xina'n. Xmān Dios tī  
cāmakapūtaxtūn. Hua'chi a'ktin talakalhu'mān tū Dios  
cāmaxquī'n. Tū lī'a'kapūtaxtucan, xla' hua'chi a'ktin  
talakalhu'mān. Jāla lītlajacan. Chuntza' jā tī tī tzē ka'tla'  
nalīmakca'tzī tū lī'a'kapūtaxtucan.

Romanos 10:9,10 Chuntza' palh huanāuj Jesús ū'tza'  
quiMāpa'ksīni'ca'n ē palh a'ka'ī'yāuj ixlīcāna' Dios  
mālacastālancuanīh, chuntza' Dios  
naquincāmakapūtaxtūyān. Palh a'ka'ī'yāuj Jesucristo  
makapūtaxtūnu'n ē palh cāhuaniyāuj ā'makapitzīn  
a'ka'ī'yāuj, chuntza' Dios quincāmakapūtaxtūyān.



Juan 3:16,17 Jesús cāhuanipālh: —Dios cāpāxquī  
ixlīpō'ktuca'n tachi'xcuhuī't xalanī'n nac cā'quilhtamacuj.

Ū'tza' līmāstā'lh tī ixlīmān ī'Ska'ta' ē chuntza' tī  
natalīpāhuan xla', xlaca'n jā makstin catitasputli. Nataka'lhī  
xasāsti' ixlatamatca'n tū jā ka'lhī ixlīsputni'. Dios macamilh  
ī'Ska'ta' nac cā'quilhtamacuj. Jā macamilh  
nacāmakapātīnīn. Macamilh nacālīmakapūtaxtū.

1 Juan 5:11-13 Ca'tzīcan ixlīcāna' tū Dios huan, ixpālacata  
quincāmaxquī'yān xasāsti' quilatamatca'n tū jā catisputli,  
palh līpāhuanāuj ī'Ska'ta'. Tī talīpāhuan ī'Ska'ta' Dios,  
xlaca'n taka'lhī xasāsti' ixlatamatca'n. Tī jā talīpāhuan  
ī'Ska'ta' Dios, xlaca'n jā taka'lhī xasāsti' ixlatamatca'n. Quit  
iccātzo'kni'mā'n huā'mā' ixpālacata hui'xina'n, tī  
līpāhua'mpā'na'ntit ī'Ska'ta' Dios, naca'tzīyā'tit palh  
ka'lhī'yā'tit xasāsti' milatamatca'n tū jā catisputli.



Juan 14; 2 Corintios 5; Apocalipsis 4, 21, 22

Storyline by: Edward D. Hughes

Illustrated by: Lazarus  
and Alastair Paterson

Adapted by: Sarah S.

Totonac Upper Necaxa NT (tku) © 1999, Wycliffe Bible  
Translators, Inc. All rights reserved.

<https://www.bible.com/bible/729/MAT.1>

©2025 Bible for Children, Inc.

[www.M1914.org](http://www.M1914.org)

[www.bibleforchildren.org](http://www.bibleforchildren.org)

