

[www.BibleForChildren.org](http://www.BibleForChildren.org)

# SAN JUAN 14

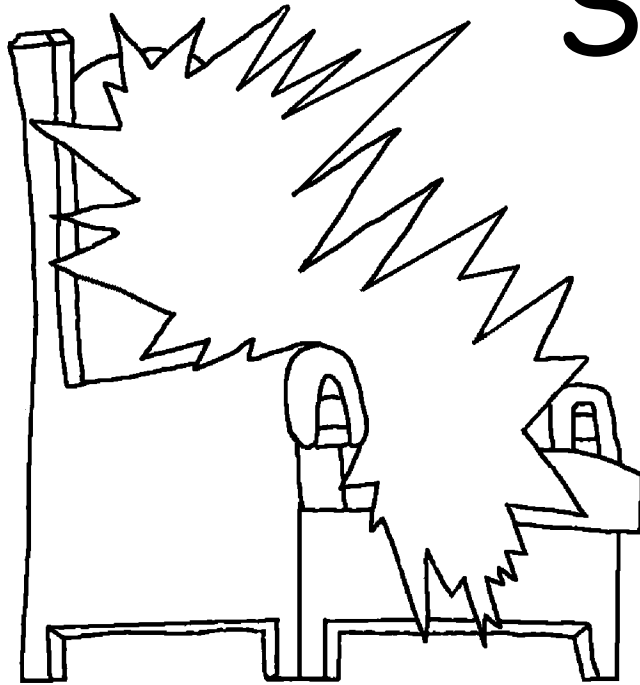

lā' Jesús cāhuanipā: —Lā' hui'xina'n tū'tza'  
catamakchuyī'tit. Calīpāhua'ntit Dios lā' nā chuntza'  
quit caquilālīpāhuáj. A'nlhā hui'lacha' quinTāta',  
a'ntza' a'nan lhūhua' pūtahuī'lhni'. Palh tū' cahuā  
chuntza', xa'iccāhuanini' hui'xina'n.



Ica'nā quit iccāxui'lī lacatin a'nlhā natahui'la'yā'tit  
a'ntza'. Lā' a'xni'ca' na'ica'n quit lā'  
na'iccāxui'līkō'yācha', quit na'icmimpala lā'  
na'iccālē'nāni' hui'xina'n. Lā' chuntza' a'nlhā  
na'ictahui'la quit, nā hui'xina'n a'ntza'  
natahui'la'yā'tit.

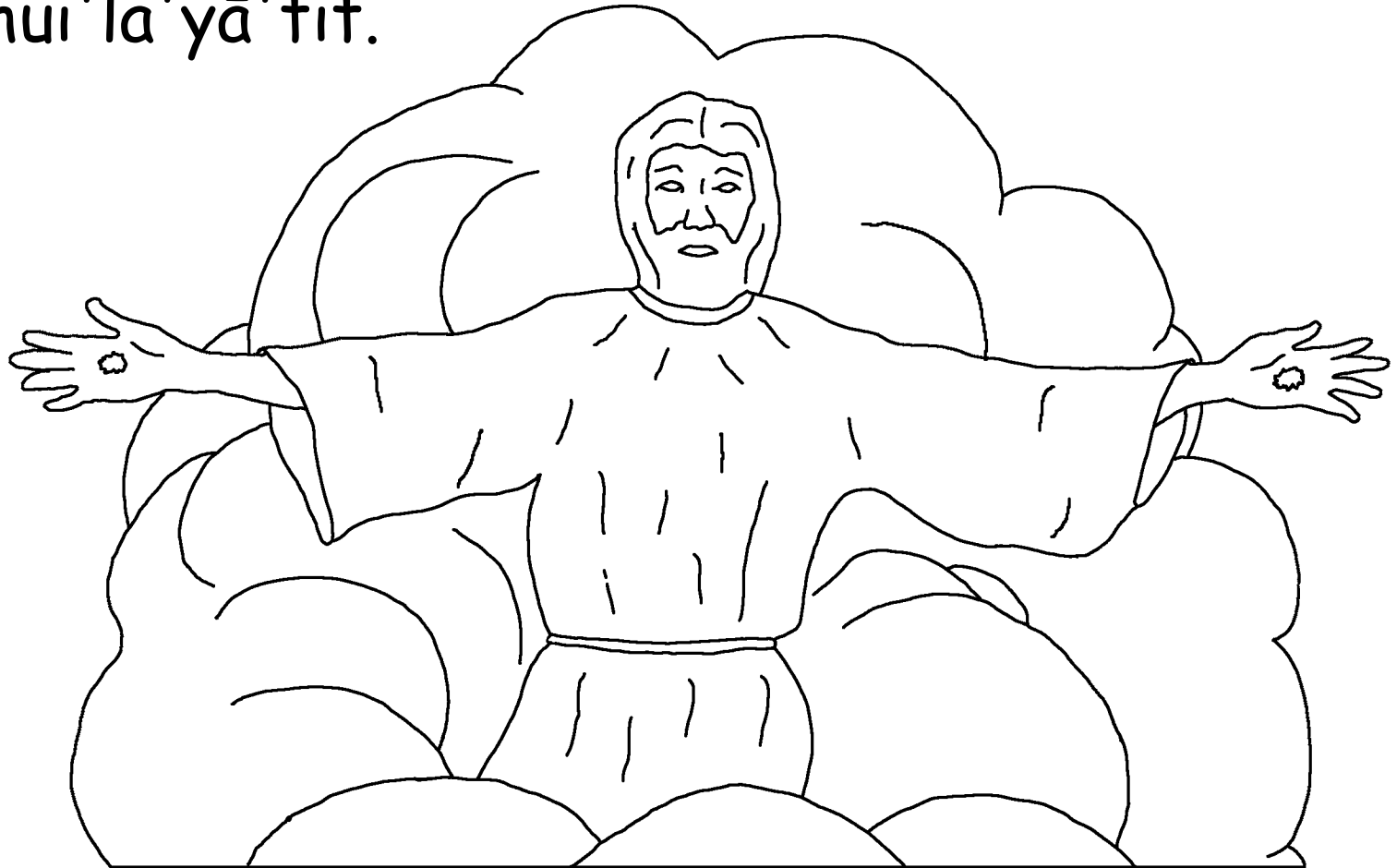

Lā' quit, Juan, mintā'tinca'n hui'xina'n. Lā'  
quina'n tapa'ksiyāuj con Jesucristo. Quit  
iccātā'pātīni'mā'ni' hui'xina'n lā'

iccātā'tāyani'yāni' con hui'xina'n por  
ixpālacata Jesucristo.

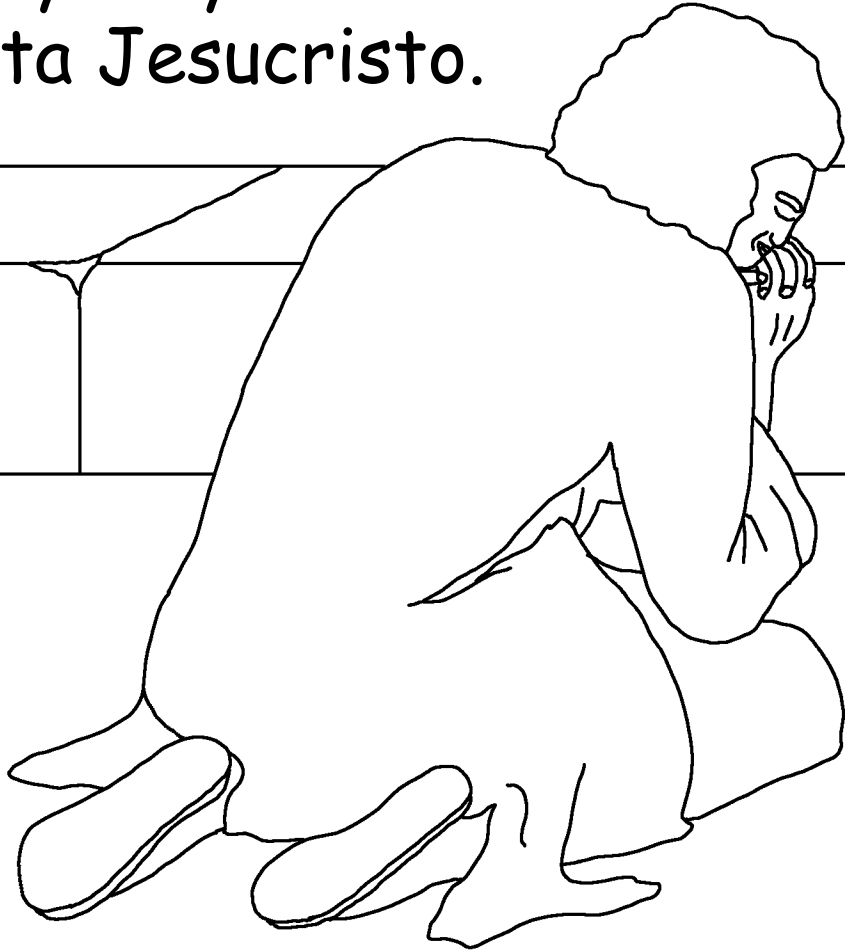

Quit quimacaminca para na'ictachoko hua'chi  
tachī'n nac Patmos a'ntū pītzina'j ti'ya't na  
ixpu'nan mar. Quinchi'pacanī't como

xa'icmāsu'yunī't ixtachihuīn Dios lā' a'ntū  
ixlīstu'ncua' ixpālacata

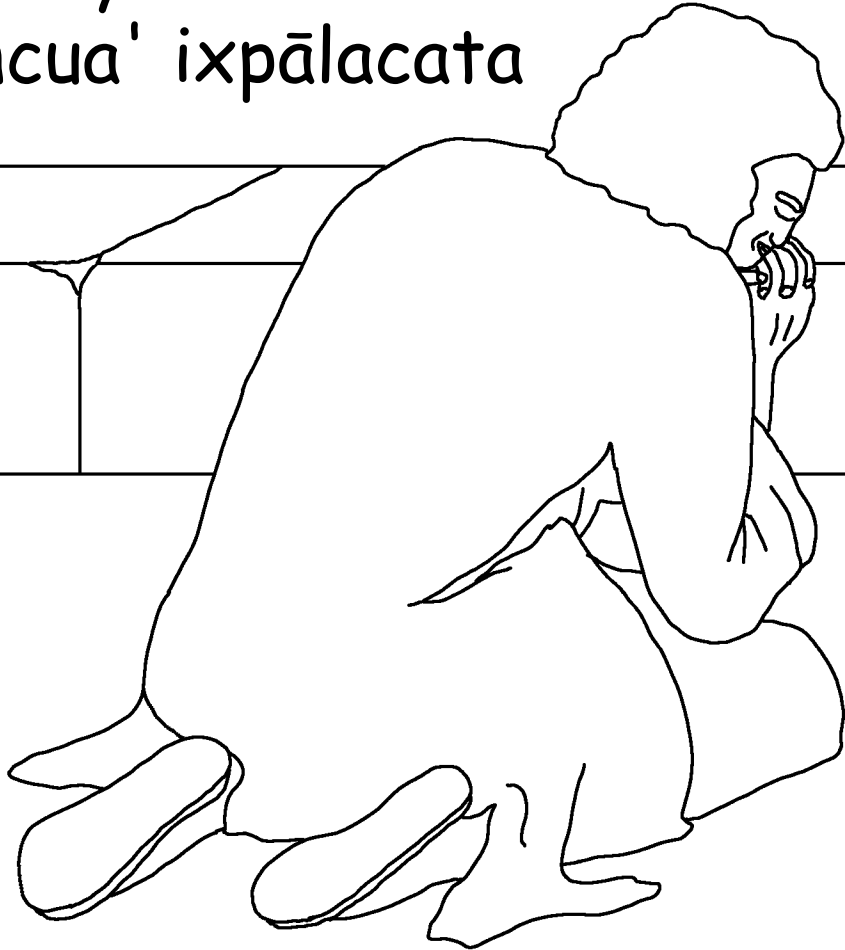

Jesucristo.



Lā' chu tuncan huan Espíritu Santo quilē'lh nac  
a'kapūn. Lā' huan nac a'kapūn ixyā lakatin pūtahūi'lh  
a'ntū ixpūmāpa'ksīn Dios lā' a'ntza' ixuī' kalhatin.

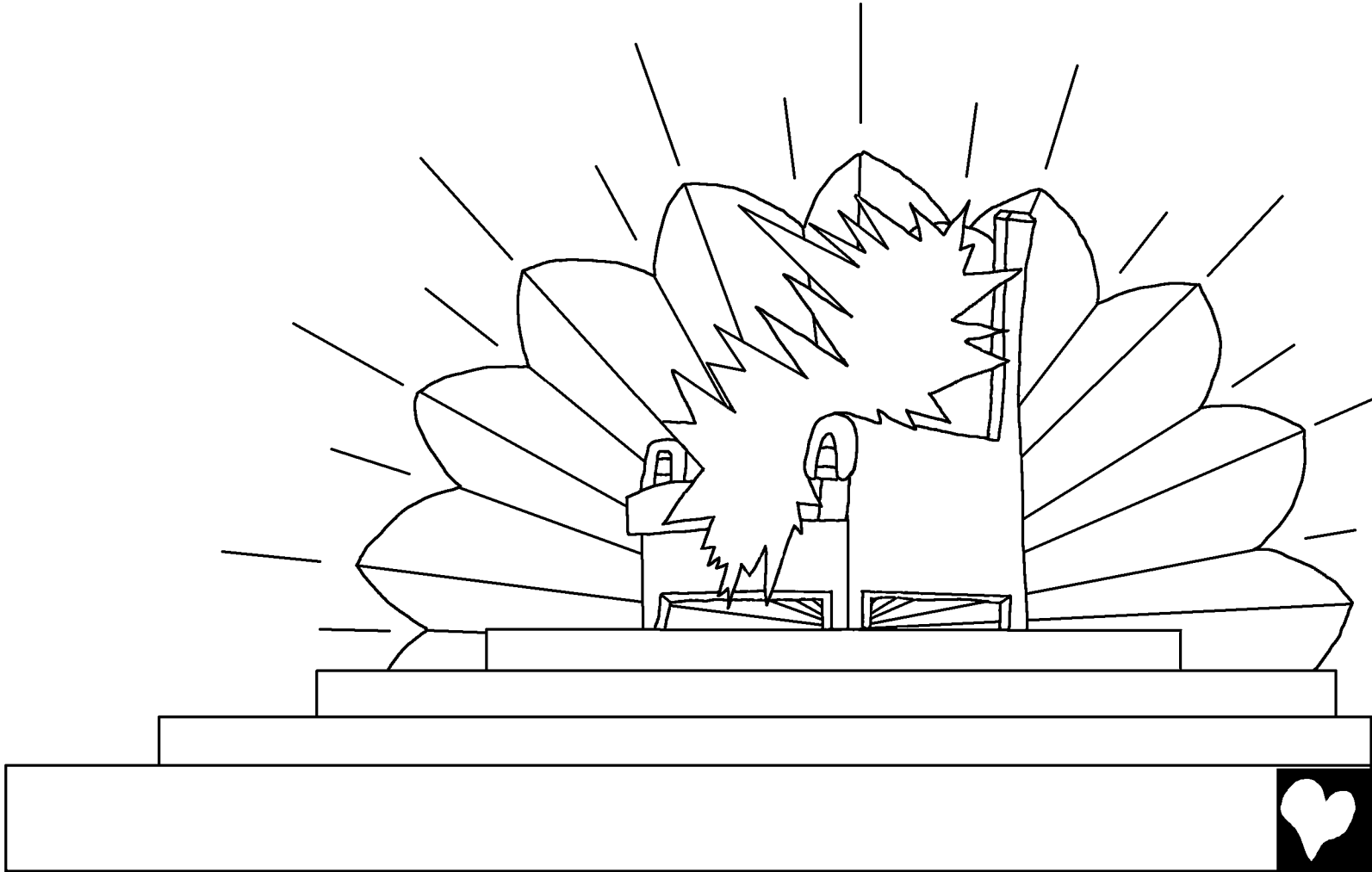

Lā' tuncan ickaxmatli a'nchīn tachihuīna'lh ixlīhuāk  
a'ntū Dios cāmā'a'nanīlh lā' mālahahuanīlh nac  
a'kapūn lā' nac cā'ti'ya'tna' lā'  
nac cā'līnīn lā' nac mar.

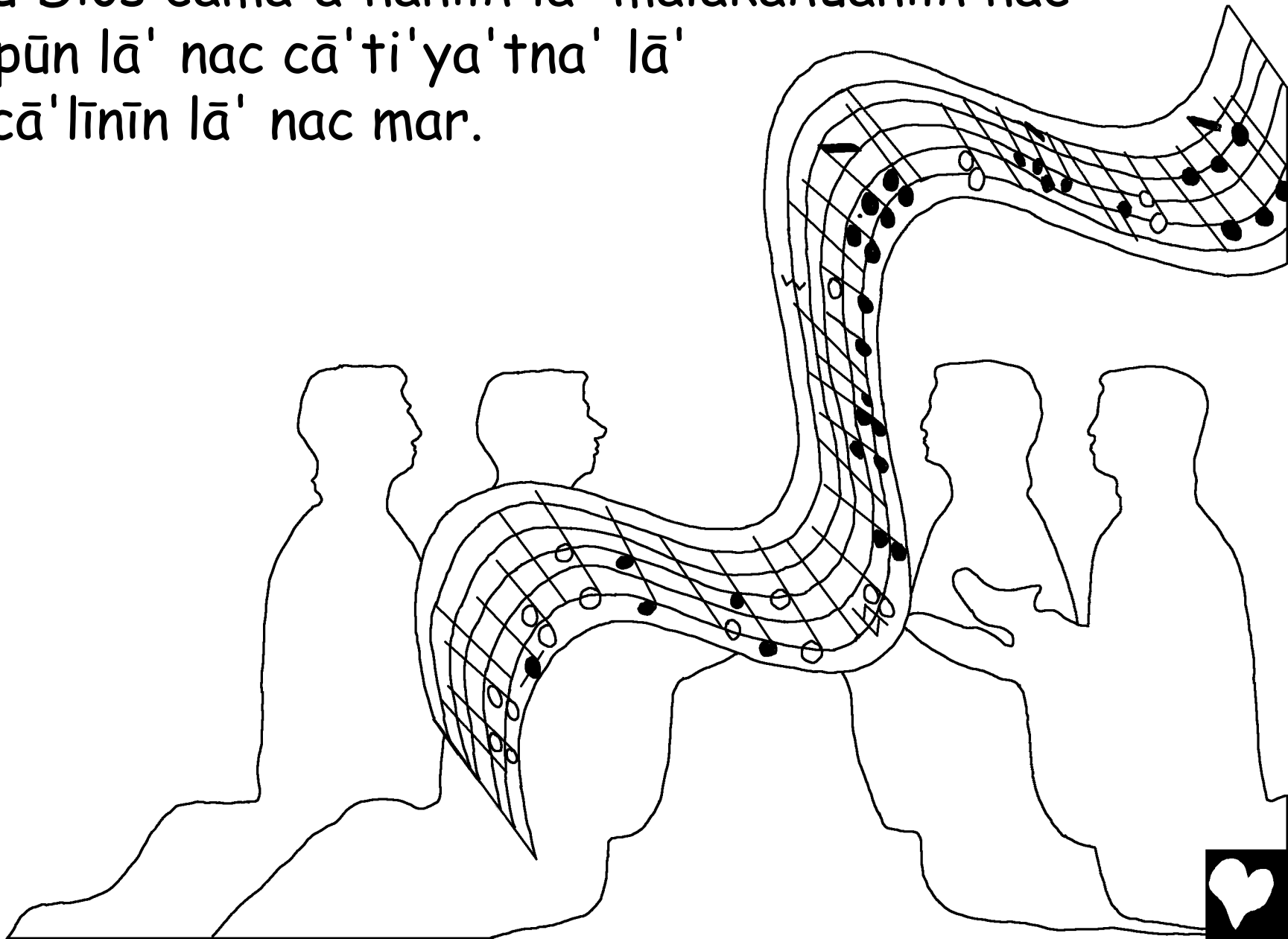

Lā' tahualh: Dios a'ntī huī' na ixpūmāpa'ksīn lā' nā  
huan Cordero cacāmācā'tanīca lā' cacā'a'cnīni'ni'ca  
lā' cacāmāpāxuhuīca. Lā' lej  
cataka'lhīlh lhūhua' līmāpa'ksīn.

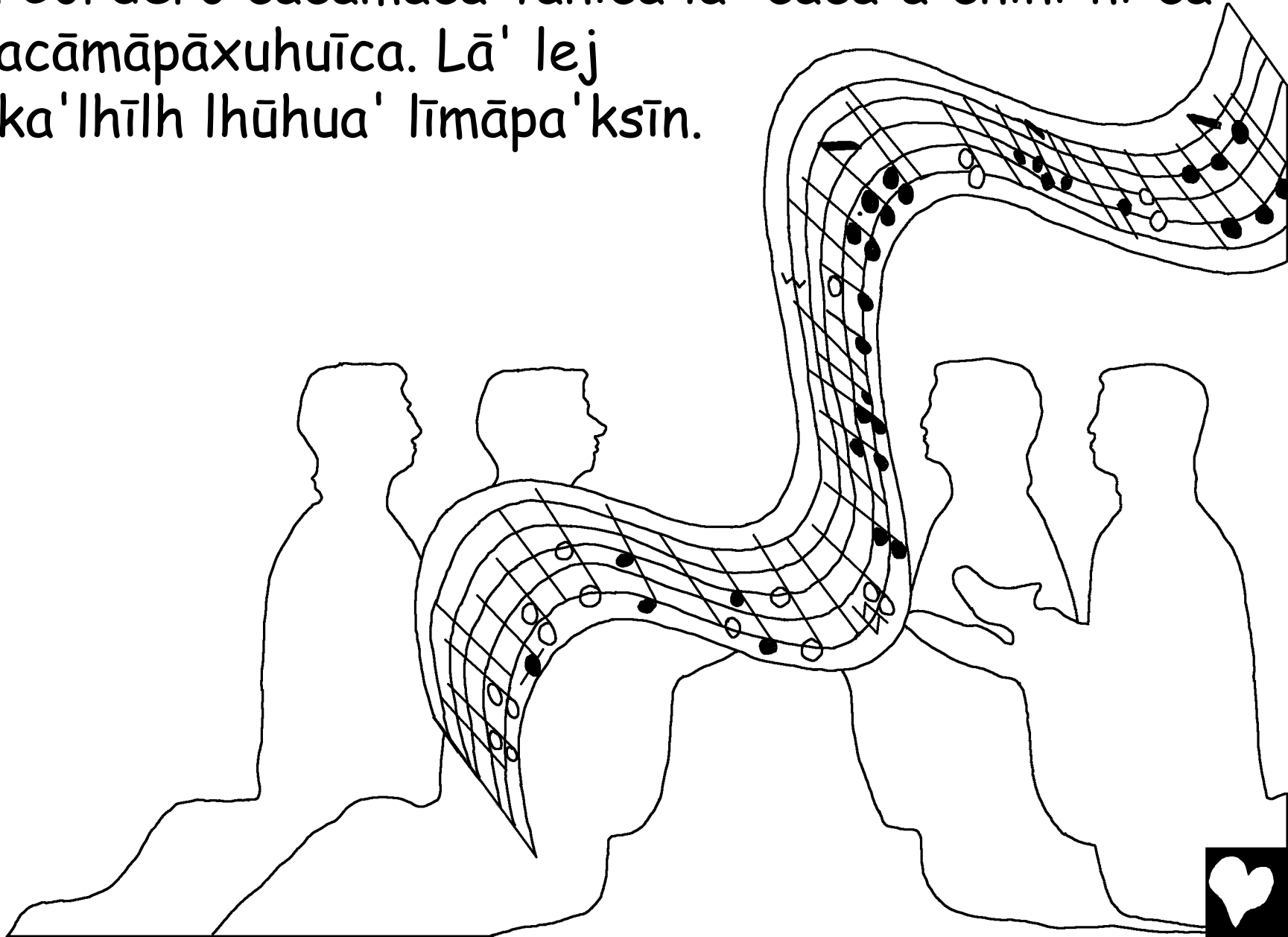

Quit iclaktzī'lh huan xatasicua'lanālīn cā'lacchicni'.  
Huā'mā' cā'lacchicni' ū'tza' a'ntū xasāsti'  
Jerusalén. Lā' nā iclaktzī'lh a'nchī ixyujmā'chi nac  
a'kapūn a'nlhā hui'lacha' Dios. Lā' huan cā'lacchicni'  
tzej ixcāxtlahuacanī't hua'chi kalhatin xatasqui'ni'  
a'ntī xa'nca  
lhakā'nan  
a'xni'ca'  
natā'tapūchahua  
huan ī'squi'nīni'.

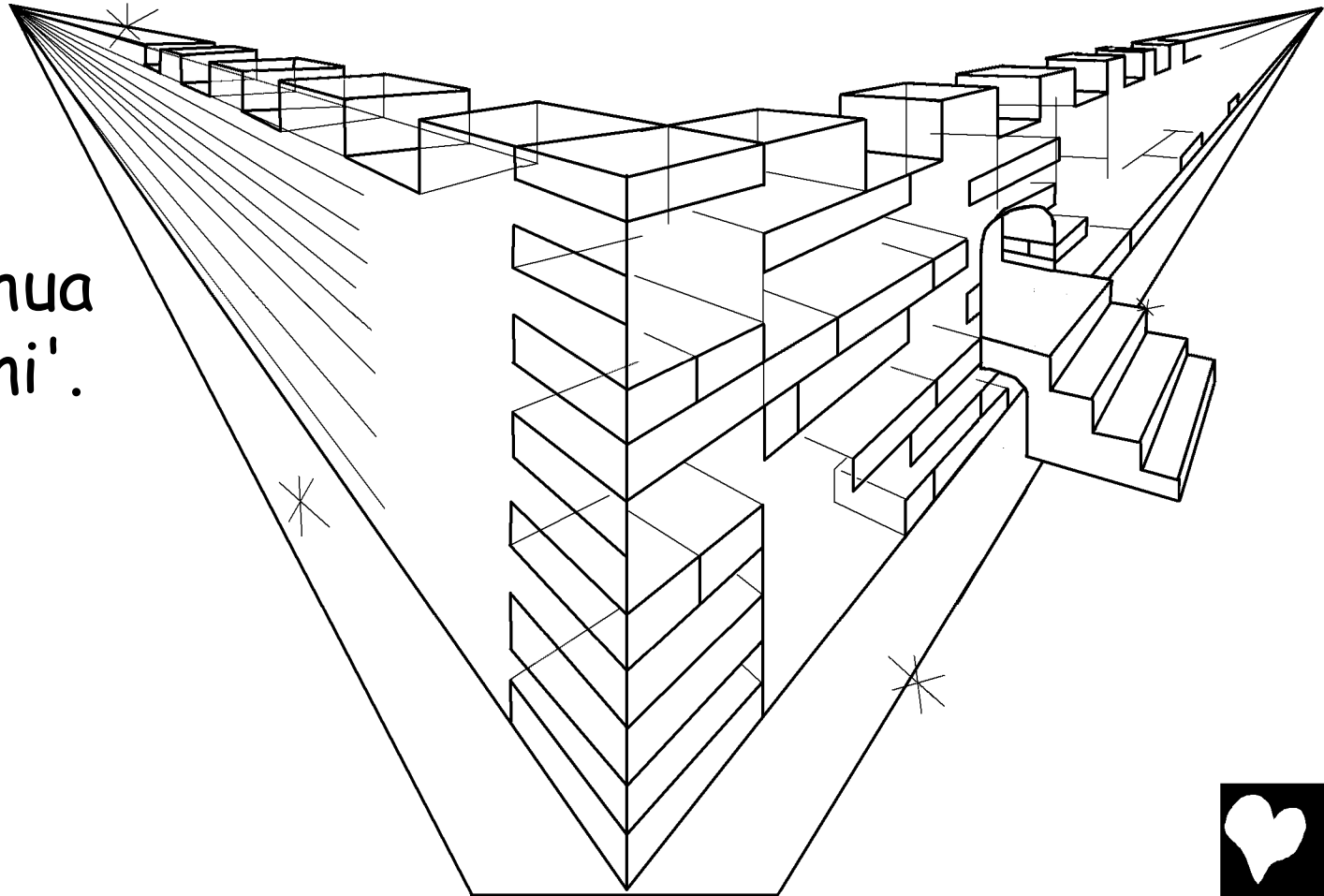

A'calīstān ickaxmatli lakatin tachihuīn a'ntū mincha'  
nac a'kapūn. Lā' lej palha' hualh: —Chuhua'j Dios  
cātā'lahuī' huan tachi'xcuhuī't. Lā' xla'  
nacātā'latahui'la con xlaca'n. Xlaca'n natala  
ixtachi'xcuhuī't. Lā' xla' nala ixDiosca'n xlaca'n.

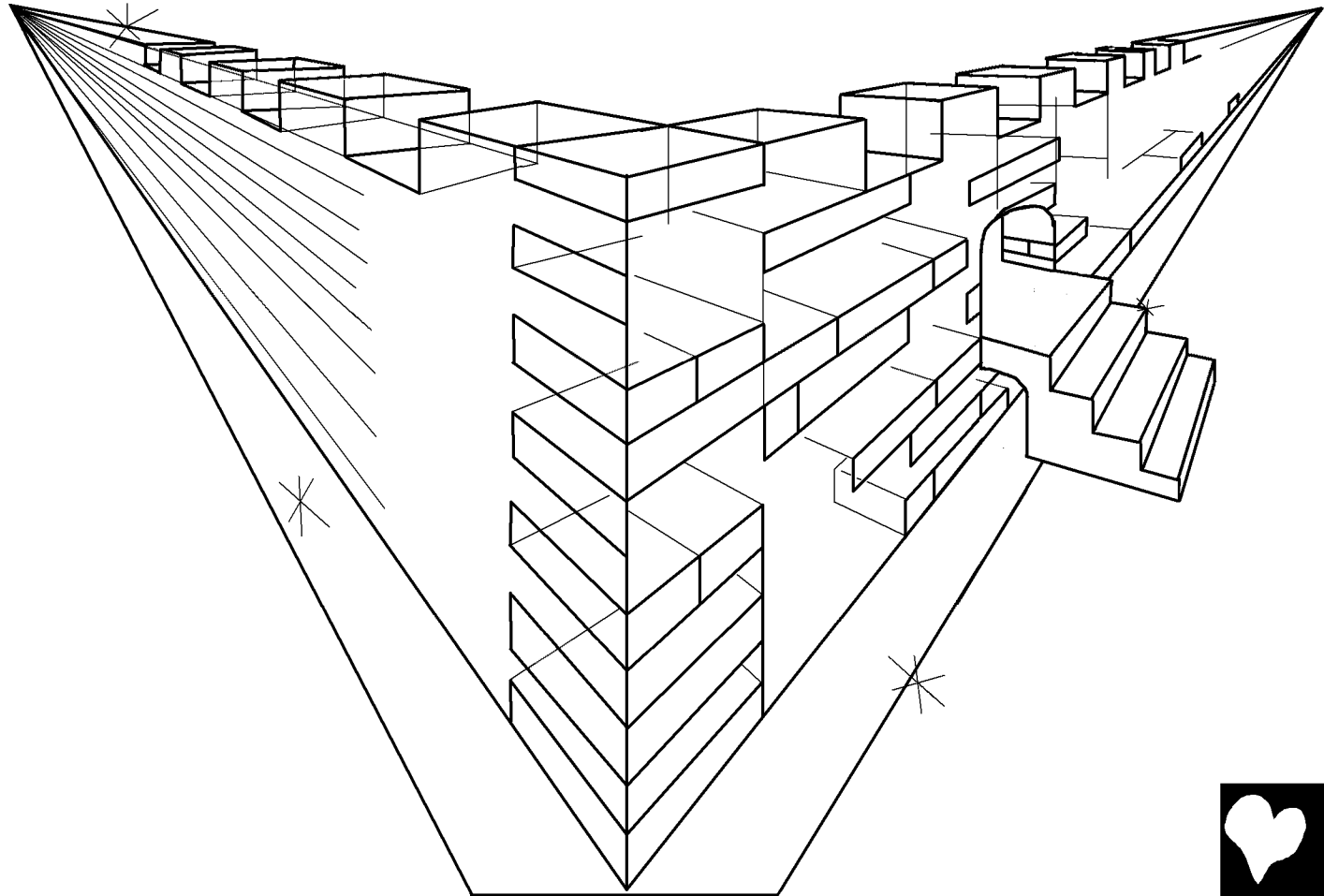

Lā' ā' calīstān huan ángel quimāsu'ni'lh kantiñ pūxka  
a'ntū lej stala'nka'. Lā' huan xaxcān de huā'mā'  
pūxka ū'tza' a'ntū māstā' huan xasāsti'  
quilhtamacuj. Huan pūxka ixtaxtumā' de na  
ixpūmāpa'ksīnca'n Dios lā' huan Cordero.

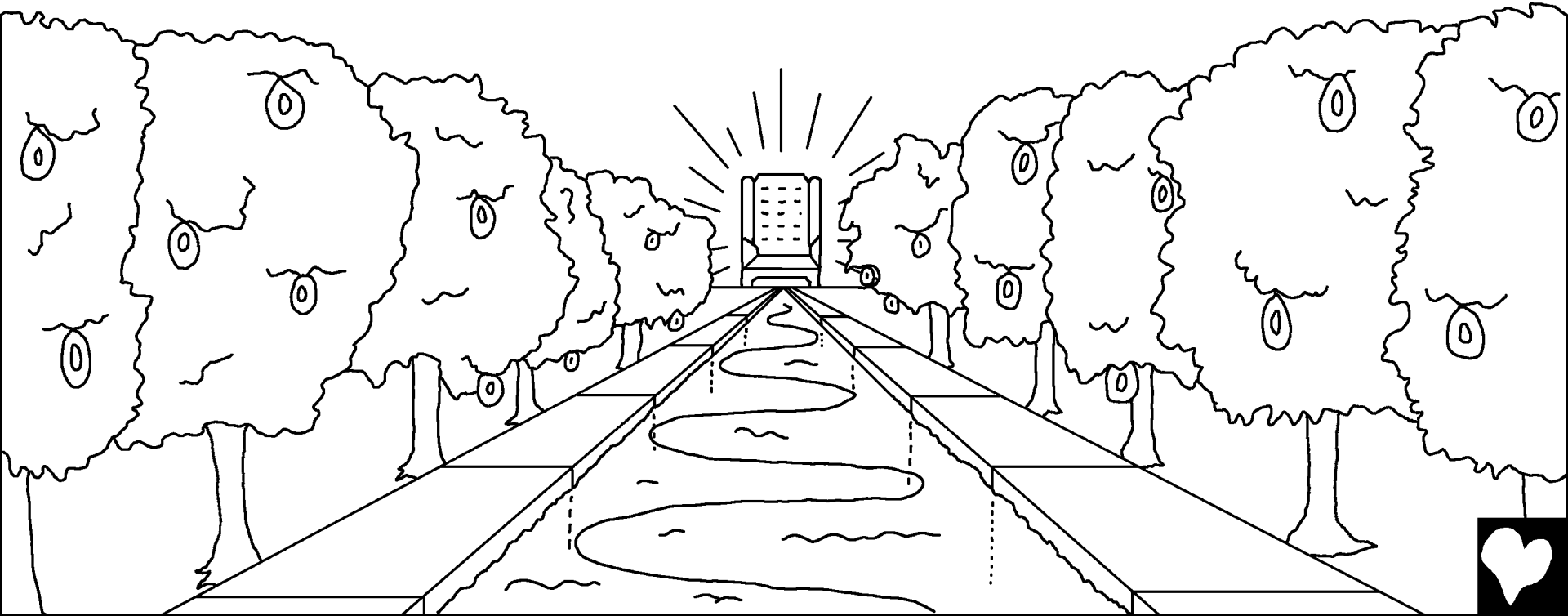

A'ntza' tū' tasqui'nī que huan chi'chini' nīn huan  
mālhcu'yu' natamāxkakēni'n huan nac cā'lacchicni'.  
Huan cā'lacchicni' māxkakē huan ī'xkakana' Dios lā'  
nā ī'xkakana' huan Cordero.



Lā' tū' catitanūlh nac huan cā' lacchicni'  
a'ntūn ko'hua'jua'. Lā' tū' catitatanūlh  
a'ntīn tatlahua a'ntū lej  
līmāxana'. Lā' tū'  
catitatanūlh a'ntīn  
tahuan tā'ksa'nīn.  
Natatanū nac huan  
cā' lacchicni' xmān  
a'ntīn cātzo'kcanī' t  
ixtacuīni' ca'n huan na  
ixlibro huan Cordero  
a'nlhān cātzo'kcanī' t  
ixtacuīni' ca'n a'ntīn  
taka'lhī xasāsti'  
ixquilhtamacujca'n.



Dios nacāmāscōhuīni'  
ixlakaxta'jatca'n xlaca'n. Lā'  
tū'tza' catitanīlh. Lā' tū'tza'  
catitalakaputzalh. Lā' tū'tza'  
catitacalhualh. Lā' tū'tza'  
catitapātīni'lh. Lā' tū'tza'  
caticāpātle'keni'lh nīn tuntū'  
a'ntū xala' xapū'la.



Tū' cati'a'nalh a'ntza' a'ntū ko'hua'jua' como  
a'ntza' huī' huan ixpūmāpa'ksīnca'n Dios lā' huan  
Cordero. Lā' natamācā'tanī Dios a'ntīn tatā'tapa'ksī.  
Lā' calacan natalaktzī'n Dios. Lā'  
nacālītankātzo'kcan  
ixtacuīni' Dios na  
ixtankānca'n a'ntīn  
tatā'tapa'ksī.



Lā' iccālaktzī'lh huan nīnī'n,lakka'tla'n lā'  
xalacti'na'j. Xlaca'n ixtayāna' na ixlacapūn Dios. Lā'  
cāmālakakē'ca huan libros. Lā' ā'calīstān  
mālakakē'palaca ā'lakatin. U'tza' huā'mā' huan libro  
a'nhān cātzo'kcanī't ixtacuīni'ca'n a'ntīn taka'lhī  
xasāsti' ixquilhtamacujca'n. Lā'  
cājuzgarlīca huan nīnī'n chu a'nchī  
ixtalatā'kchokonī't chuntza'  
a'nchī ixtatzo'kni'  
ixlīhuāk a'ntū  
ixtatlahuanī't.

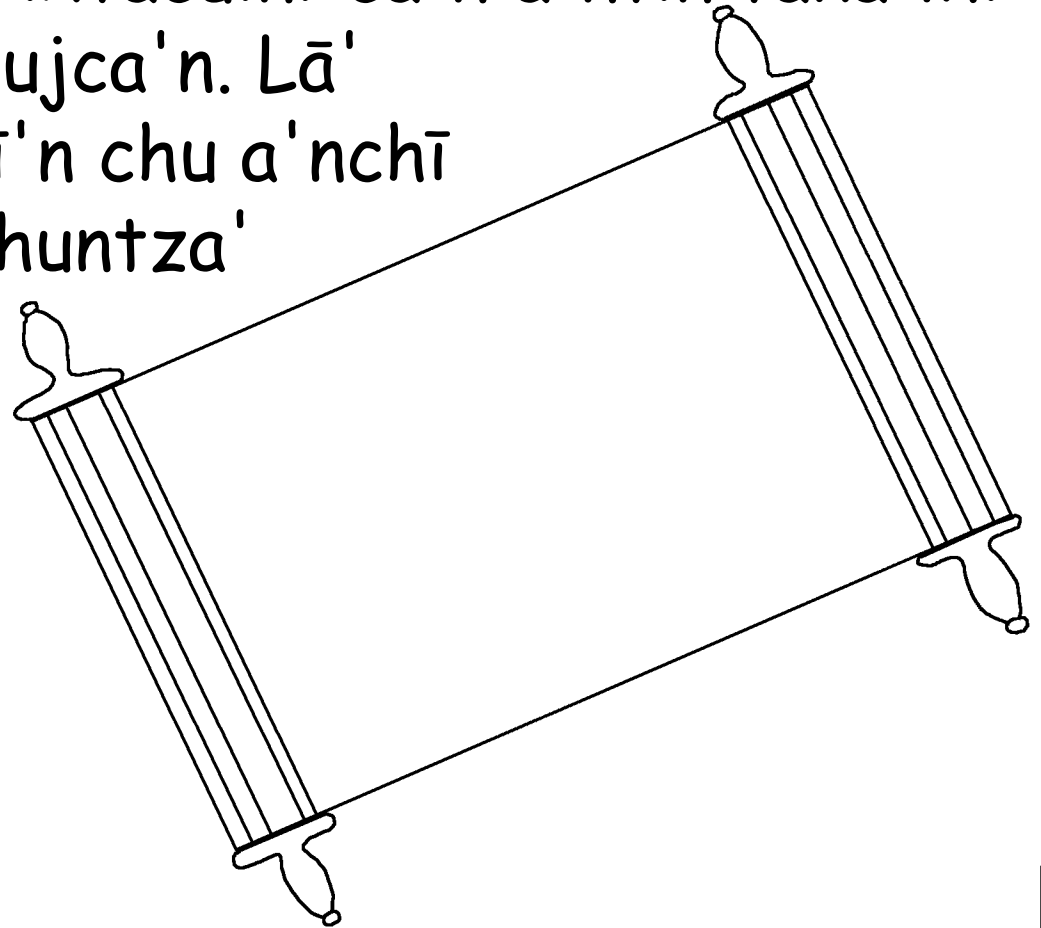

Lā' nā cāmacā'nca nac cā'macscutnu' ixlīhuākca'n  
a'ntīn tū' ixcātzō'kni'canī't ixtacuīni'ca'n huan nac  
libro a'nlhān tatzō'kni' ixtacuīni'ca'n a'ntīn taka'lhī  
xasāsti' ixquilhtamacujca'n.

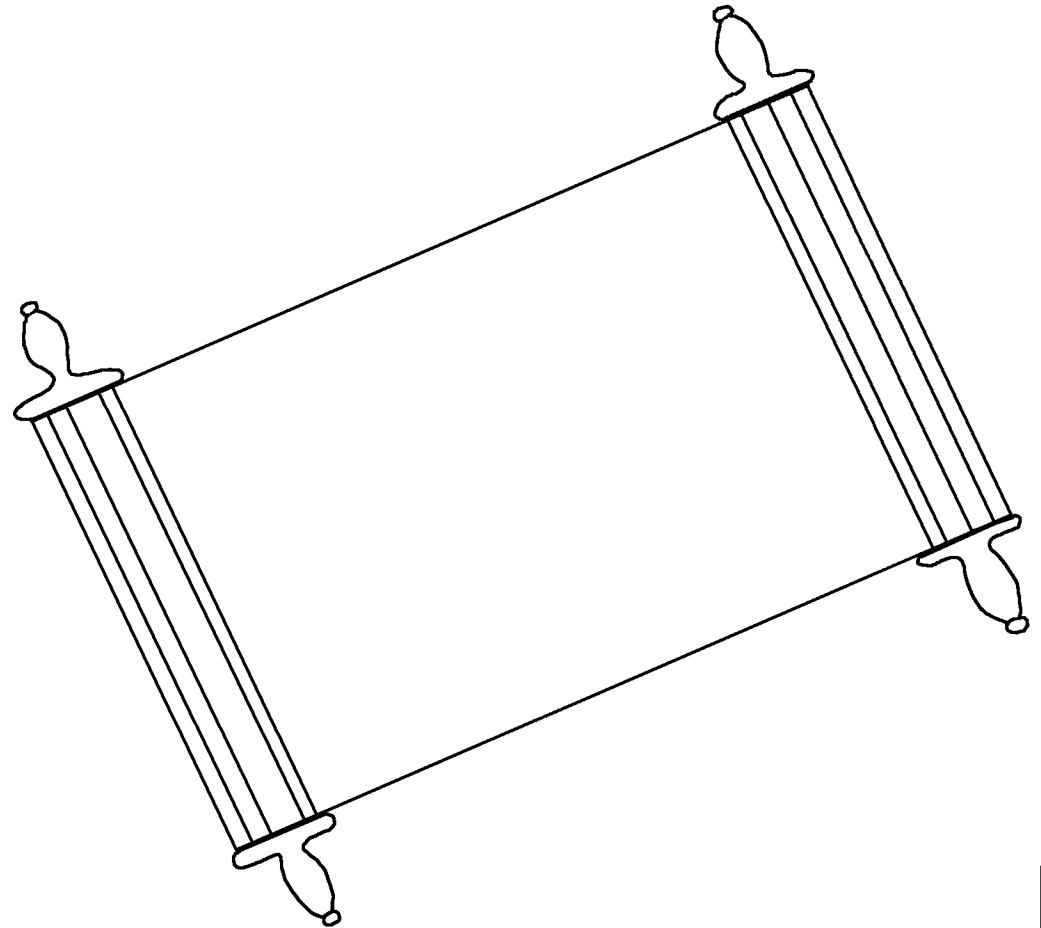

Huan Espíritu Santo lā' huan ixtasqui'ni' huan  
Cordero, xlaca'n tahuan: —Cata'ntit. Lā' ixlīhuākca'n  
a'ntīn takaxmata catahualh: —Cata'ntit.



Lā' cataminkō'lh ixlīhuākca'n a'ntīn takalhpūtī, lā'  
catahua'lh huan xcān a'ntū māstā' xasāsti'  
quilhtamacuj. Māstā' can hua'chi lē'ksajna' para  
a'ntīn tamaklhtīni'ncu'tun.

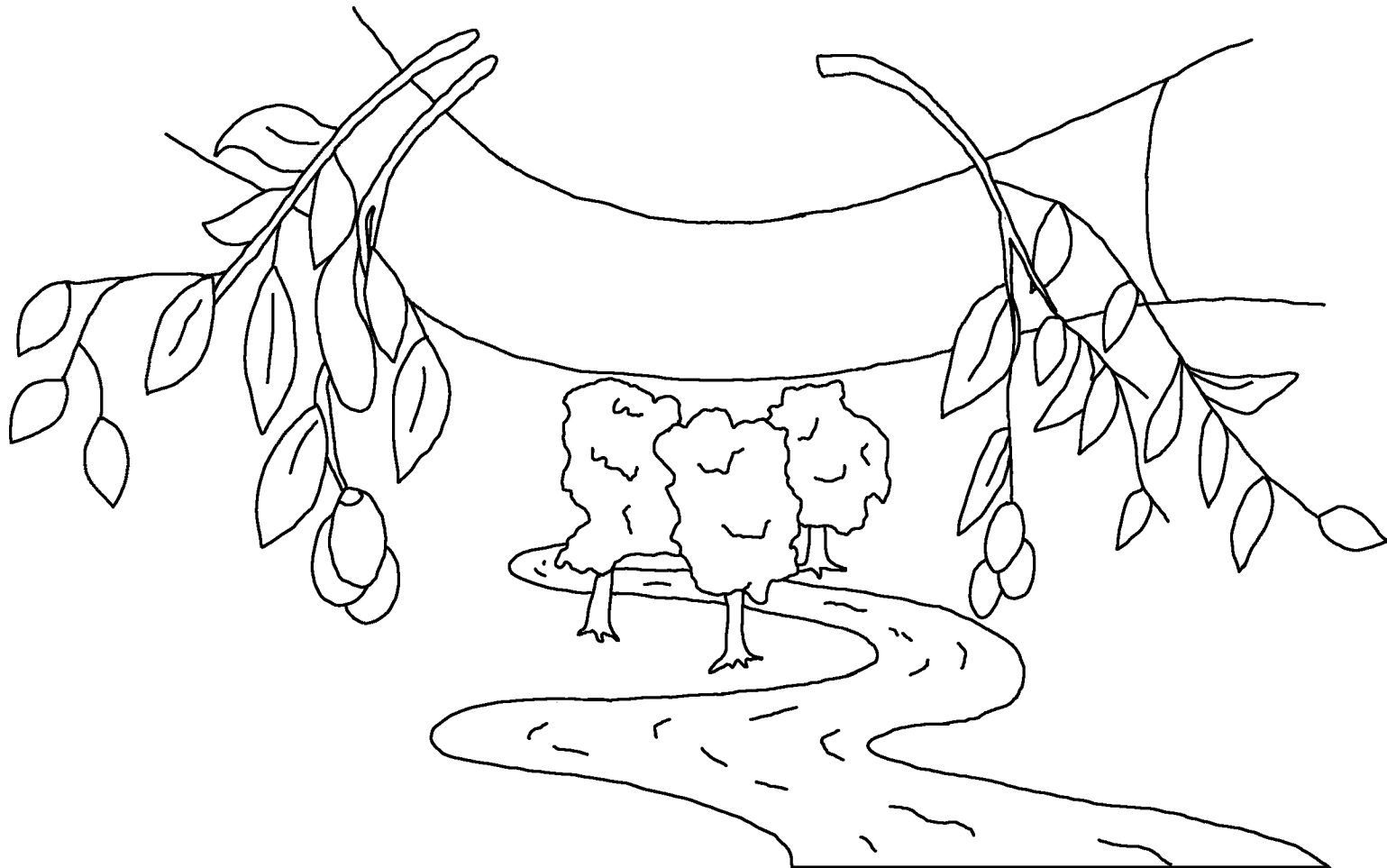

Lā' Jesús cāhuanipā: —Dios lej  
cāpāxquī' ixlīhuākca'n huan  
tachi'xcuhuī' t xalanī'n nac  
quilhtamacuj.



U'tza' līmāstā'lh ixO'kxa' a'ntī  
xmān kalhatin ixuanī't para que  
chuntza' ixlīhuākca'n a'ntīn  
talīpāhuan xla', xlaca'n tū' maktin  
catitasputli. Nataka'lhī xasāsti'  
ixquilhtamacujca'n a'ntū  
natāyani' para  
pō'ktu.



ROMANOS 3:23 Quilīhuākca'n tlahuanī'ta'uj  
quintalaclē'i'ca'n. Nīn tintī' a'ntī līlacatejtin  
latā'kchoko chuntza' hua'chi Dios lacasqui'n.

ROMANOS 6:23 Xlaca'n a'ntī cāmāpa'ksī a'ntū  
ko'hua'jua', xlaca'n natamaklhtīni'n a'ntū hua'chi  
ixtatlajca'n, lā' ū'tza' huan līnīn. Dios  
quincāmaxquī'yāni' a'ntū hua'chi lē'ksajna', lā' ū'tza'  
xasāsti' quinquilhtamacujca'n a'ntū para pō'ktu.  
Ixlihuākca'n a'ntīn takalhlaka'ī' que quiMāpa'ksīni'ca'n  
Jesucristo tzē māpūtaxtūnu'n, xlaca'n cāmaxquī'can  
xasāsti' ixquilhtamacujca'n para pō'ktu.

HEBREOS 9:27 Quilīhuākca'n nanīyāuj xmān maktin.  
Lā' ā'calīstān Dios naquincājuzgarliyāni'.



EFESIOS 2:8,9 Lā' como hui' xina' n līpāhua' nā' tit Jesucristo, Dios cāmāpūtaxtūni' hui' xina' n xmān como cālakalhu' mani'. Lā' tū' por a' ntū tlahua' tit hui' xina' n. Xmān Dios a' ntī cāmāpūtaxtūni'. Hua' chi lakatin lē' ksajna' a' ntū Dios cāmaxquī' ni'. Lā' a' ntū līpūtaxtucan, xla' hua' chi lakatin lē' ksajna'. Tūla tlahuacan nīn tuntū' para natlajacan. Lā' chuntza' tintī' a' ntī tzē nalīka' tla' jca' tzī por a' ntū līpūtaxtu.

ROMANOS 10:9,10 Lā' chuntza' palh huanāuj que Jesús ū' tza' qui Māpa' ksīni' ca' n lā' palh kalhlaka' ī' yāuj que stu' ncuā' Dios mālahahuanīchokolh, chuntza' Dios naquincāmāpūtaxtūyāni'. Palh kalhlaka' ī' yāuj que Jesucristo māpūtaxtūnu' n lā' palh cāhuanīyāuj ā' makapitzīn palh kalhlaka' ī' yāuj, chuntza' Dios quincāmāpūtaxtūyāni' lā' Dios quincāmāpānūni' yāni' quintalaclē' i' ca' n.



SAN JUAN 3:16,17 Lā' Jesús cāhuanipā: —Dios lej cāpāxquī' ixlīhuākca'n huan tachi'xcuhuī't xalanī'n nac quilhtamacuj. U'tza' līmāstā'lh ixO'kxa' a'ntī xmān kalhatin ixuanī't para que chuntza' ixlīhuākca'n a'ntīn talīpāhuan xla', xlaca'n tū' maktin catitasputli. Nataka'lhī xasāsti' ixquilhtamacujca'n a'ntū natāyani' para pō'ktu. Dios macamilh ixO'kxa' nac quilhtamacuj. Tū' macamilh para nacāmāpātīnī xalanī'n nac cā'quilhtamacuj. Macamilh para que xlaca'n natapūtaxtu. Ixlīhuākca'n a'ntīn takahlaka'ī' ixO'kxa' Dios, xlaca'n natapūtaxtu.



1 JUAN 5:11-13 Lā' Dios mālacstū'nca palh ū'tza'  
quincāmaxquī'yāni' xasāsti' quinquilhtamacujca'n a'ntū  
para pō'ktu, palh līpāhuanāuj ixO'kxa'. A'ntīn talīpāhuan  
ixO'kxa' Dios, xlaca'n taka'lhī xasāsti'  
ixquilhtamacujca'n. Lā' a'ntīn tū' talīpāhuan ixO'kxa'  
Dios, xlaca'n tū' taka'lhī xasāsti' ixquilhtamacujca'n.  
Quit iccātzo'kni'mā'ni' huā'mā': Hui'xina'n a'ntī  
līpāhua'mpā'na'ntit ixO'kxa' Dios como quit, iclacasqui'n  
que hui'xina'n naca'tzīyā'tit palh ka'lhī'yā'tit xasāsti'  
minquilhtamacujca'n a'ntū para pō'ktu.



SAN JUAN 14; 2 CORINTHIOS 5;  
APOCALIPSIS 4, 21, 22

Storyline by: Edward D. Hughes

Illustrated by: Lazarus  
and Alastair Paterson

Adapted by: Sarah S.

Totonac Xicotepec De Juarez NT (too) © 1978,  
Wycliffe Bible Translators, Inc. All rights reserved.

<https://www.bible.com/bible/780/MAT.1>

©2025 Bible for Children, Inc.

[www.M1914.org](http://www.M1914.org)

[www.bibleforchildren.org](http://www.bibleforchildren.org)

