

[www.BibleForChildren.org](http://www.BibleForChildren.org)

# Diyoni 14



Iyesu e tadeyau kabukabuwa ragidai ade tadebu, wagubu ke; "Wi notaga eba koyogono kudu eba wainapiyoi. Nau Mamai God e mena sumapiyoi ade nau mete sumasiniyoi. Nau Mamai e tawai rabineya ka wata ropani kawayu uburau."



“Ki pokere yewe idiwoi mibai ka nau kayasugani wi wataga yamanapani. Nau wi wataga ki eba yamanapena maba ki ka nau yona yau matarau wi eba nidibena.”



"Nau wi wataga yamanapani kewoyagisi ki ka nau ewa  
ade wirasugani bausugani manako nau wi teniyani da  
nau yo wi ewapuru kaigamu nau tondana tawanai ki ika  
ewapuru idiwomu."

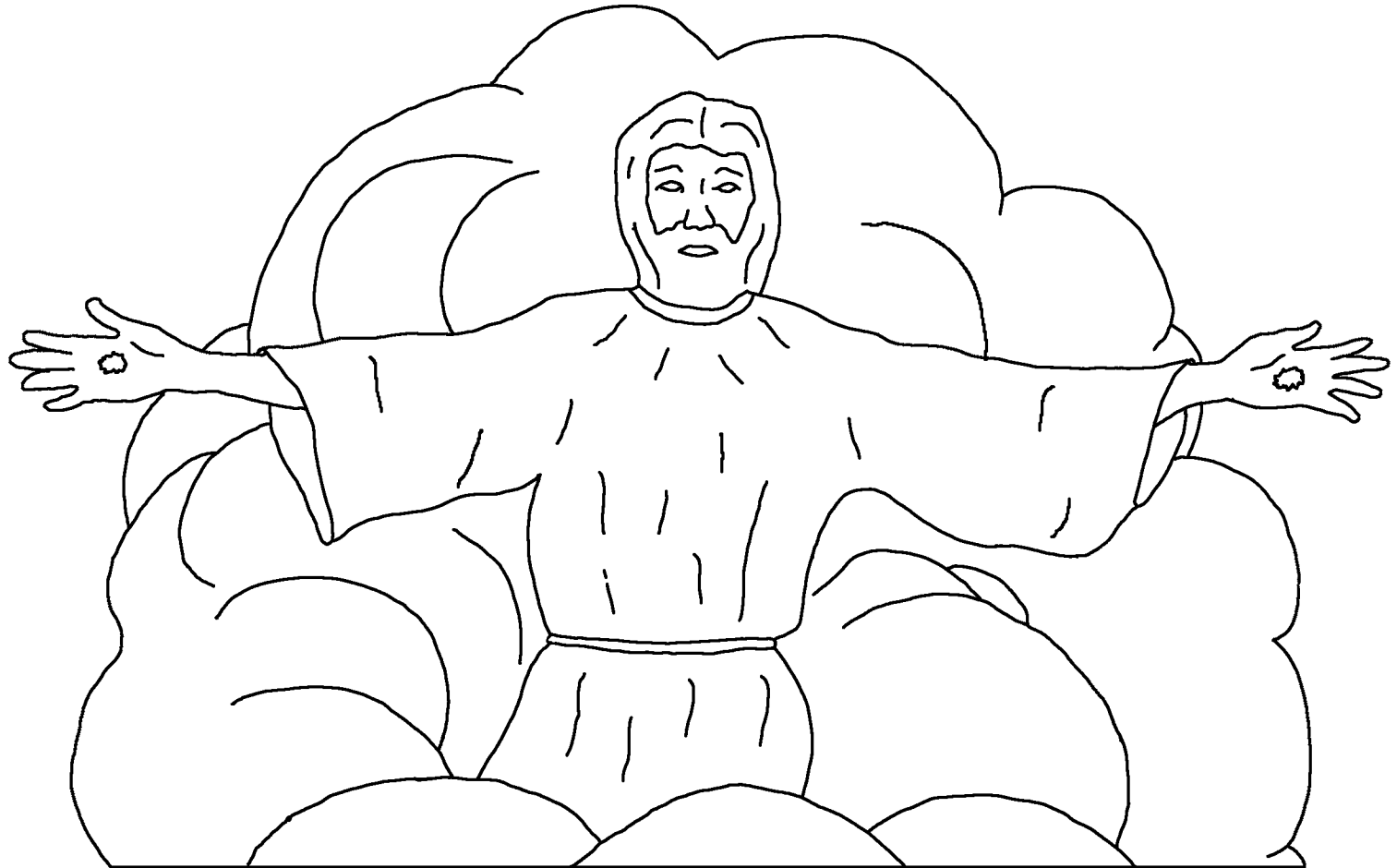

Nau ka Diyoni, wi sumaga mete ewapuru eyaka  
mena ki apunai. Nu ka Iyesu e naureya idiwei  
ade e gari rabineya kaiwana e kasiyarai

pokaiya idiwana ki nawanai nu idiwei.  
E pokaiya ka nu midi



makari mete  
bananapemei ade  
giruru maba kobaiya  
teteigemei ko nu  
eba kekeraigemei.



Mamanuga God e yonai ade Iyesu e yonai bagi  
kawaya ki nau dimasugekeya iyapana  
tadeyekeya umekeya ki pokere mu nau

wadisinimupu ruku mosi si ka Pasimosi ki  
kawareya nau

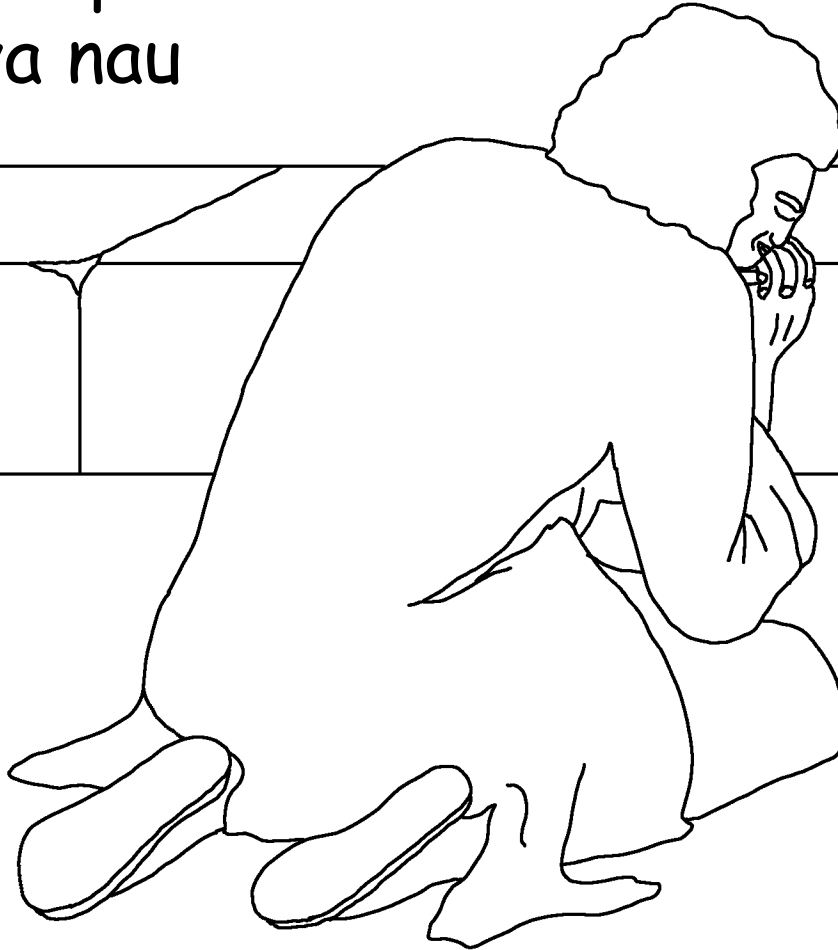

tamusini-mupu.



Ki makeya ka Mamanuga God e Keyai garugaru mena bauwena nau kawarineya minibu siwa yabirisinibu manako nau usi kunumau kema bagi kawayu mosi empuwani. Kema ki kawareya ka nau iyapana mosi ika tondawa empuwani.

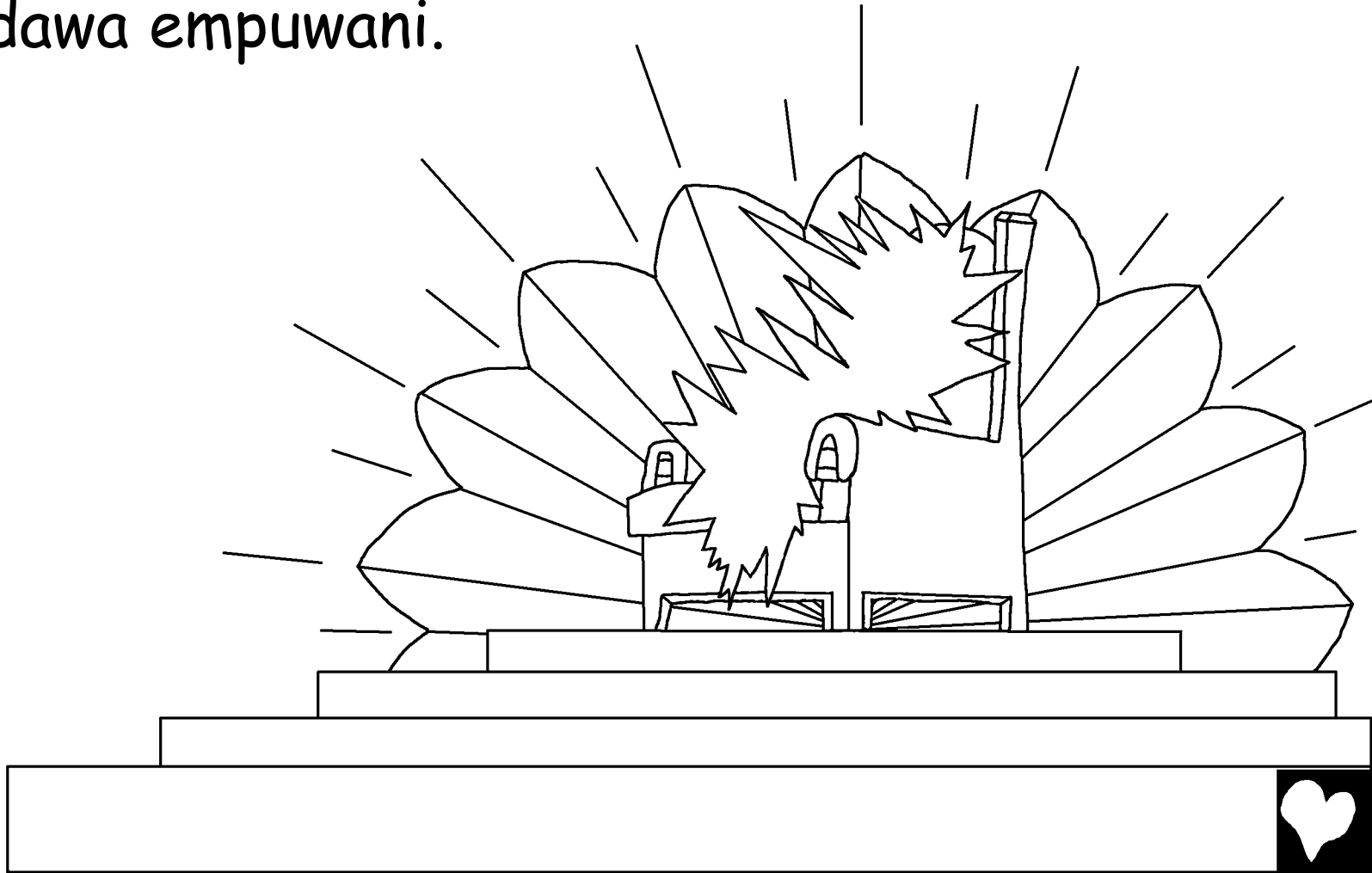

Aneya ropani kawayaya ki inako tagubu manako ki eweya  
ka nau gwedegwede kuduba iyaiya ika kunumau,  
waira kawareya, waira kobaiya, ade  
egi rabineya mete kina,  
gwedegwede kuduba inako  
madega kauwagau madega  
posiwagau ki mu umayo yau  
tagamawa  
wainapuwani; ...

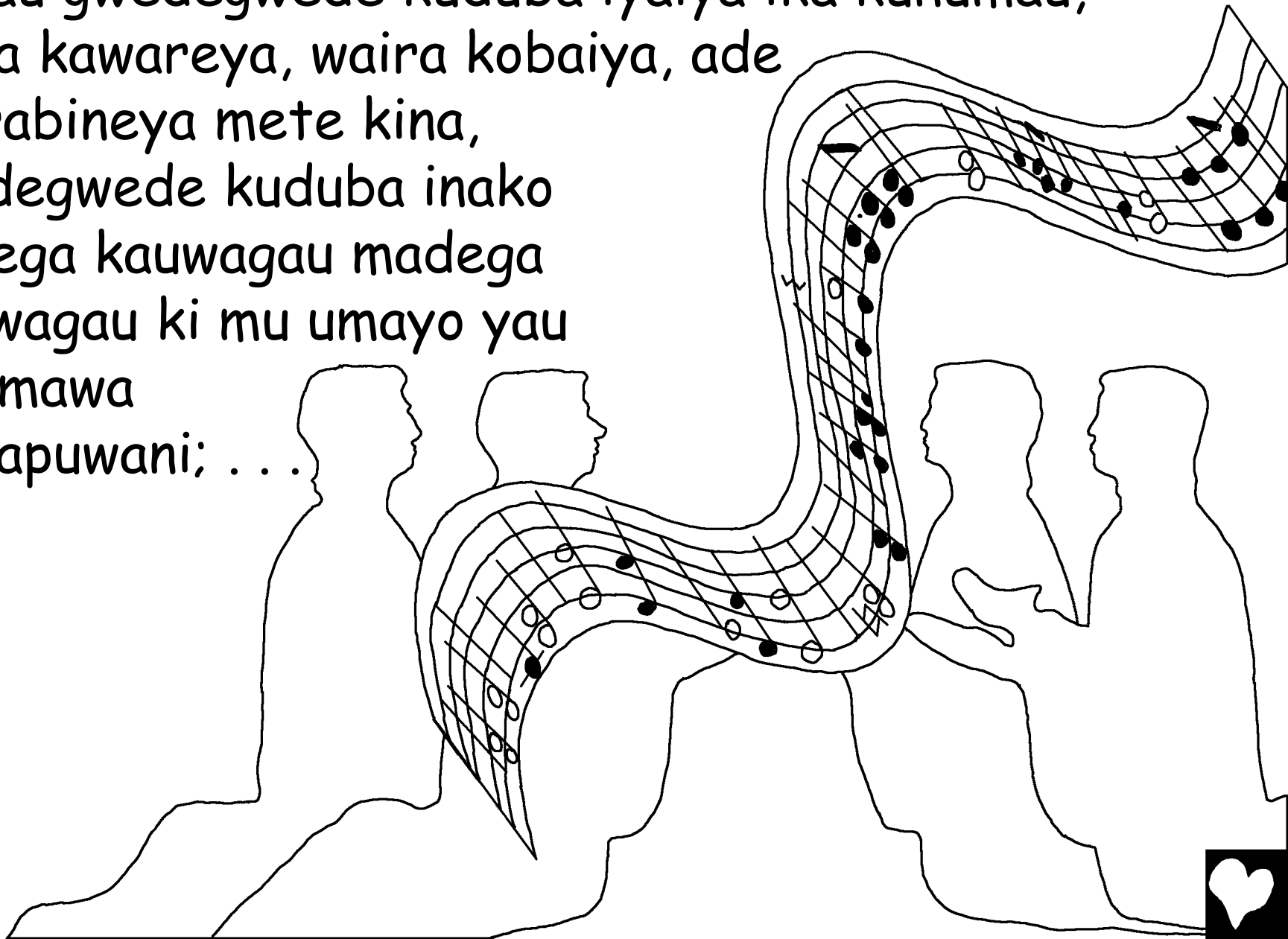

... 'Kema kawareya tondei apunai ade papa sipi  
munai, wi kasiyaraga ka kawayi daganani esida.  
Nu wi paraunimei, wi wiwiranimei,  
ade wi siga maramara esida  
tepapemei.'



Nau yabu tapuwani manako natere Diyerusaremu  
Waunai Tanai Bagi Kawaya ki Mamanuga God e  
deneya kunuma were kawarawa ki nau empuwani.  
Natere ki ka onowa apunu uwarana monagai wadubu ki  
maba monagawena kawapu empuwani.

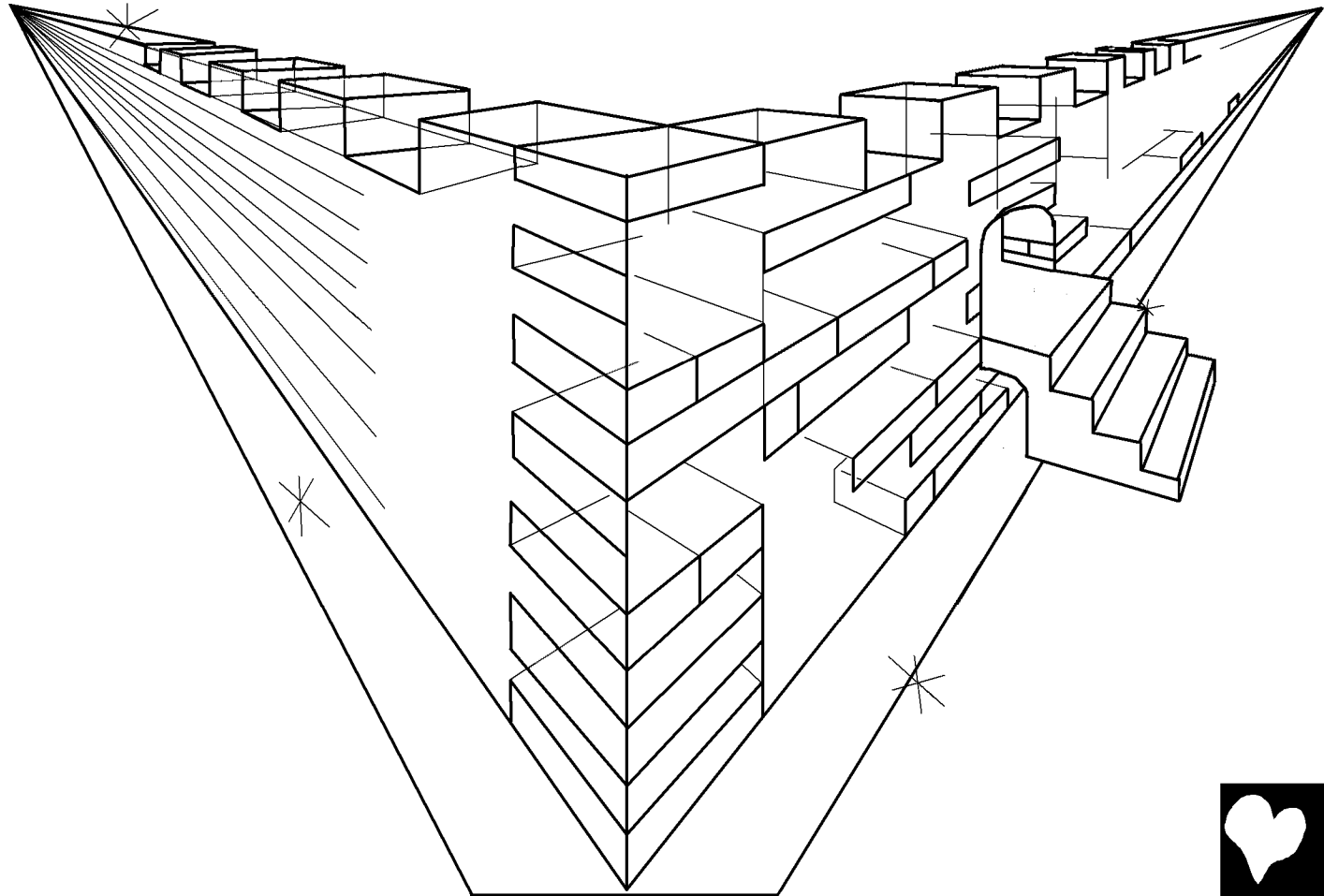

Bonana ragiragi kawayá mosi Mamanuga God e kemai  
ki deneya bauwena ki nau mete wainapuwani. Bonana  
ki wagubu ke; 'Wainapumuri, Mamanuga God e karako  
iyapana mu bamamugu bauwena. E mu paunamugu mu  
mete ewapuru idiwono ki pokere e iyapanaiyoma

mibai ka  
muyo ade mu  
Mamamaga  
God ka eyo.

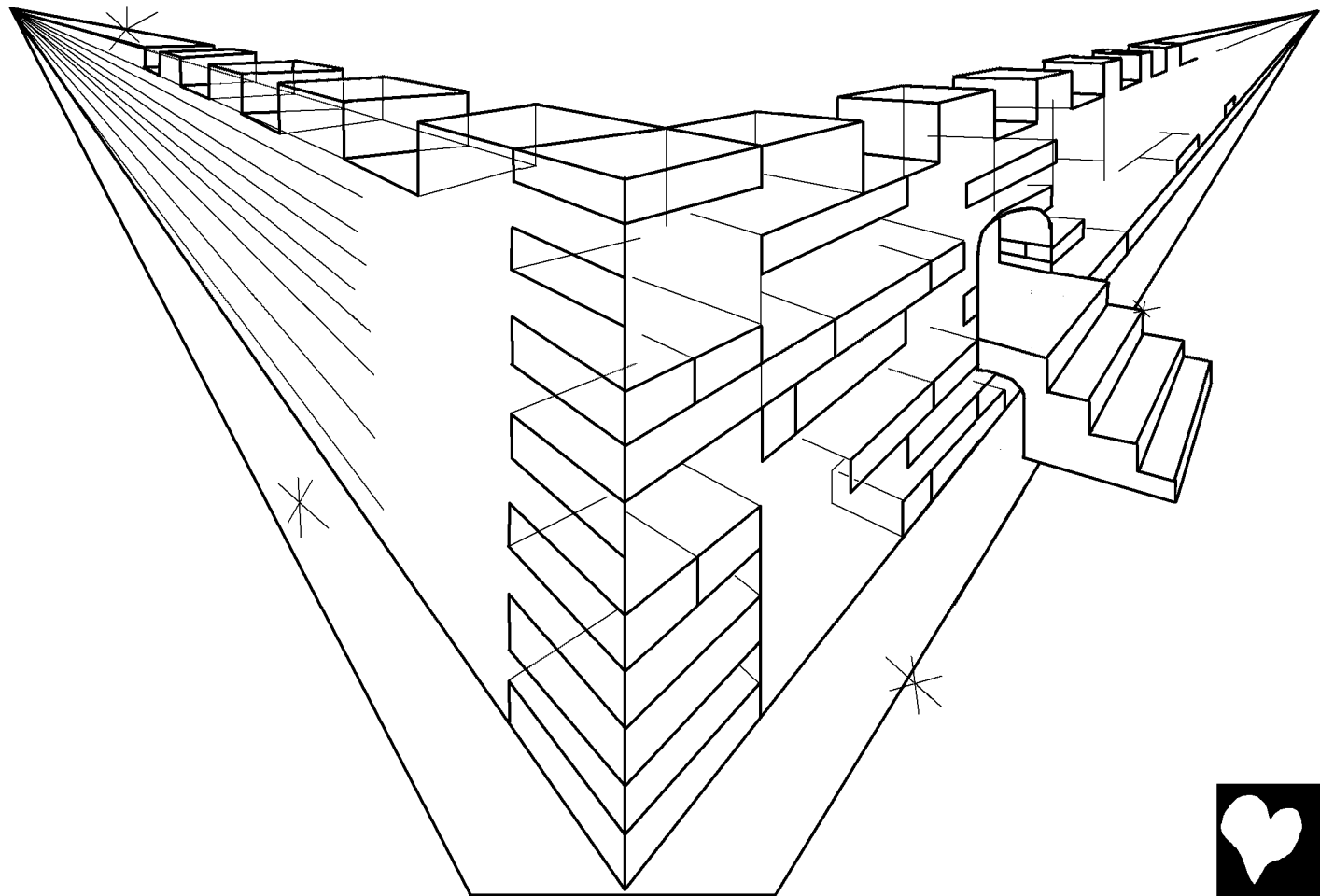

Aneya ki Iya Awanai usirapiyau nau mete kabuwasinibu. Awana ki ka negai kawayana nainiwara kawareya wadau. E Mamanuga God ade Papa Sipi Munai mu kemamaga kobaiya usira-piyawa, natere ki imateya bauwagawa kayawagawa ki nau empuwani.

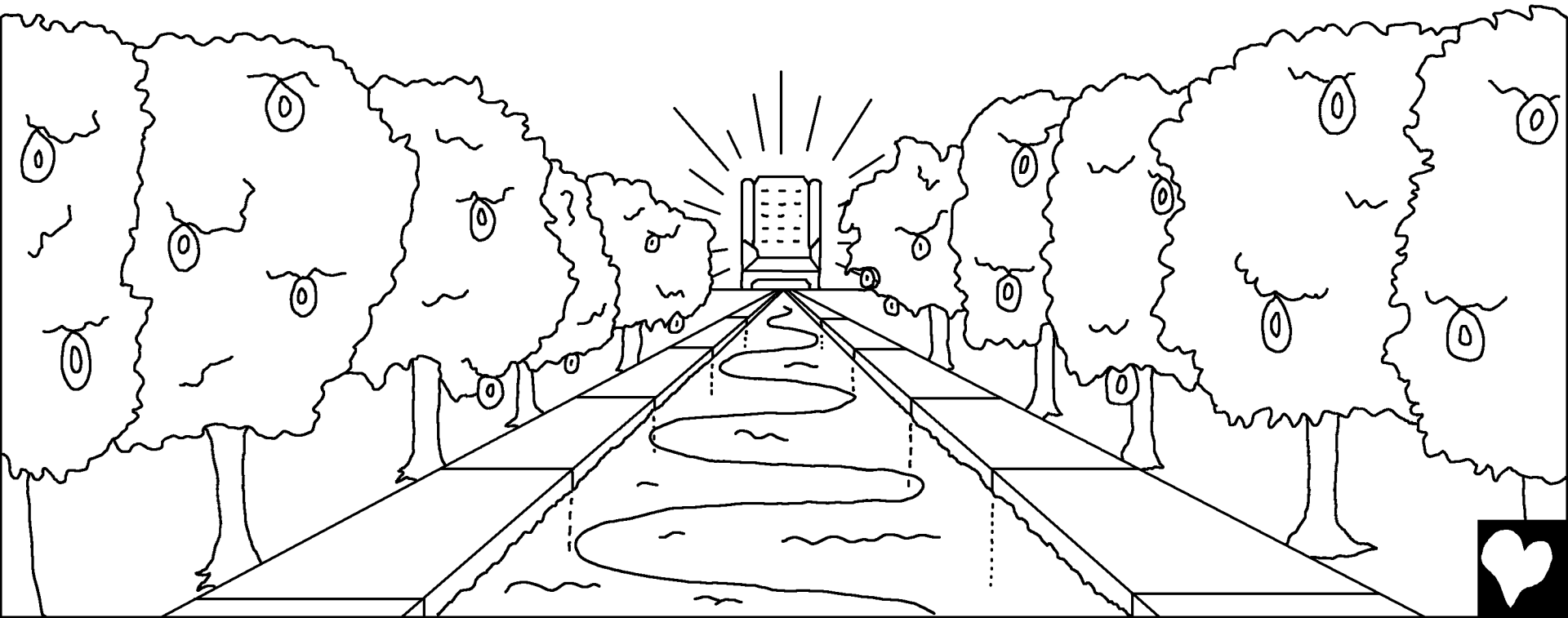

Mamanuga God e eya Tanai Bagi Kawayá natere ki miniyau siwa ki pokere iyapana madega bo siragamu tanai nene eba notapomono. Natere ki dunai ka Papa Sipi Munai ki kena.

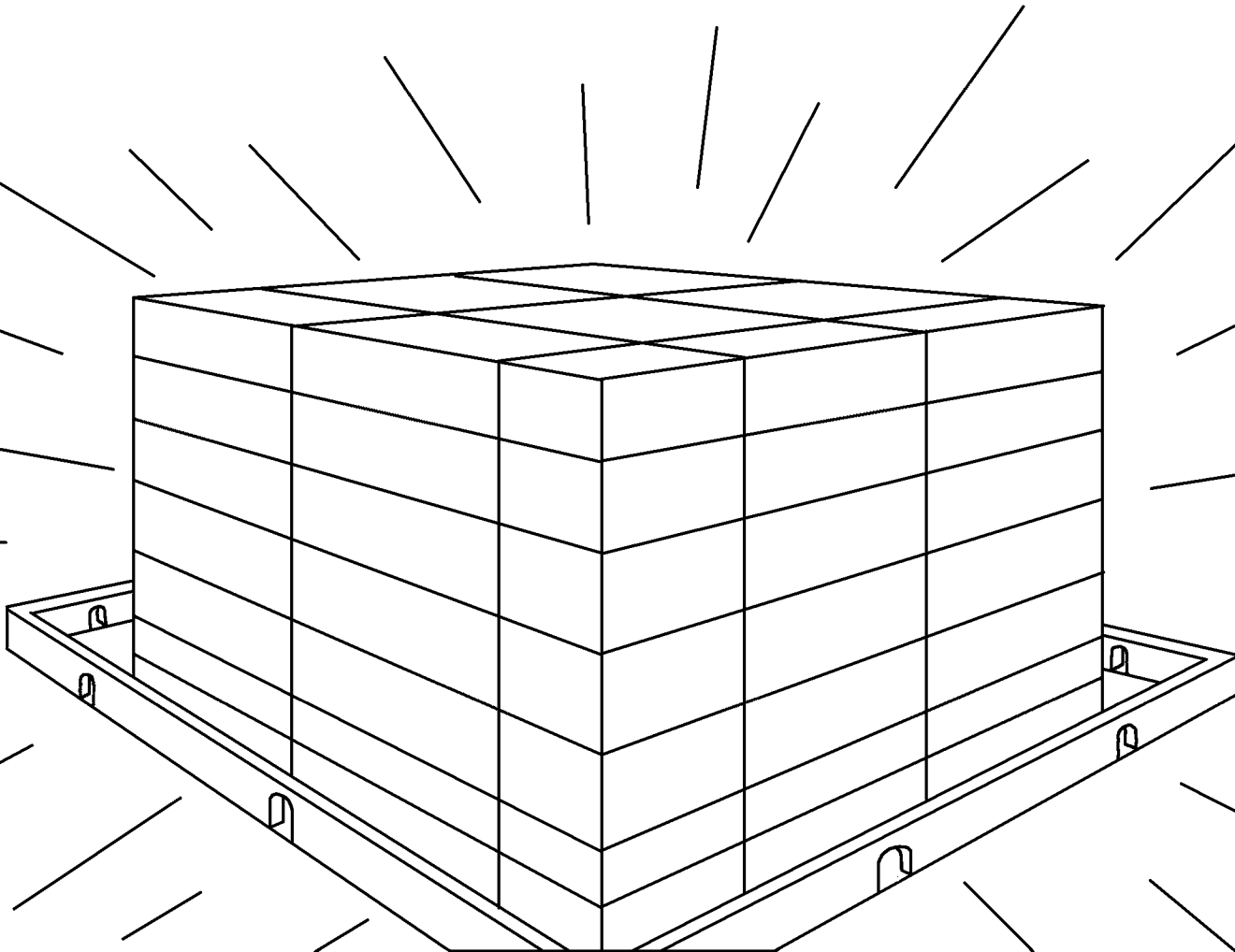

Ko gwede mo bigibigi bo iyapana midimama berai  
kwaetagamu bo beratagamu mu ka natere ki rabineya  
eba kaiwoto. Pa mena. Ko iyapana  
gwedewau mu simaga Papa  
Sipi Munai e Iya Bukai  
rabineya okapupu ki mu  
mena ka natere ki  
rabineya kaiwoto.



Mu yabumaga iwai ki e  
surupoto. Karako ka po pa  
mena, nuwaboya pa mena, yadi  
pa mena ade makari mete pa  
mena. *Gwedegwede* oragai ki  
kuduba goga-wena.' Bonana ki  
inako wagubu.



Mamanuga God e gwede mosi kowaga eba kweyoto ki pokere gwede e eba nuwaiya ki natere ki rabineya eba kaniyoto. Mama-nuga God ade Papa Sipi Munai mu kemamaga ka ika mete kina ki pokere Mamanuga God e bigabigaiyoma e si ika esida mena tepapomono idiwono. Mu e kiyabui matarau empomoto ade e eya si mu yabaramugu mete okapoto.



Popotagubu ragidai marai kawai ika Mamanuga God e  
kemai yabareya ubumawa ki nau mu emitapuwani  
manako aneya dai bau-tagubu buka dai dadaratampu  
ade Iya Bukai ki mete dadaramupu. Iyapana eyaka  
eyaka badidi kwaetagamawa buka  
wagubu ki makeya makeya ka mu  
eyaka eyaka denai mete  
wadumupu. Iyapana  
nima e si Iya Bukai  
ki rabineya pa mena  
ki ka Mamanuga God  
uburoto e yadini mata  
maramara urau ki  
nonareya kwenupoto.

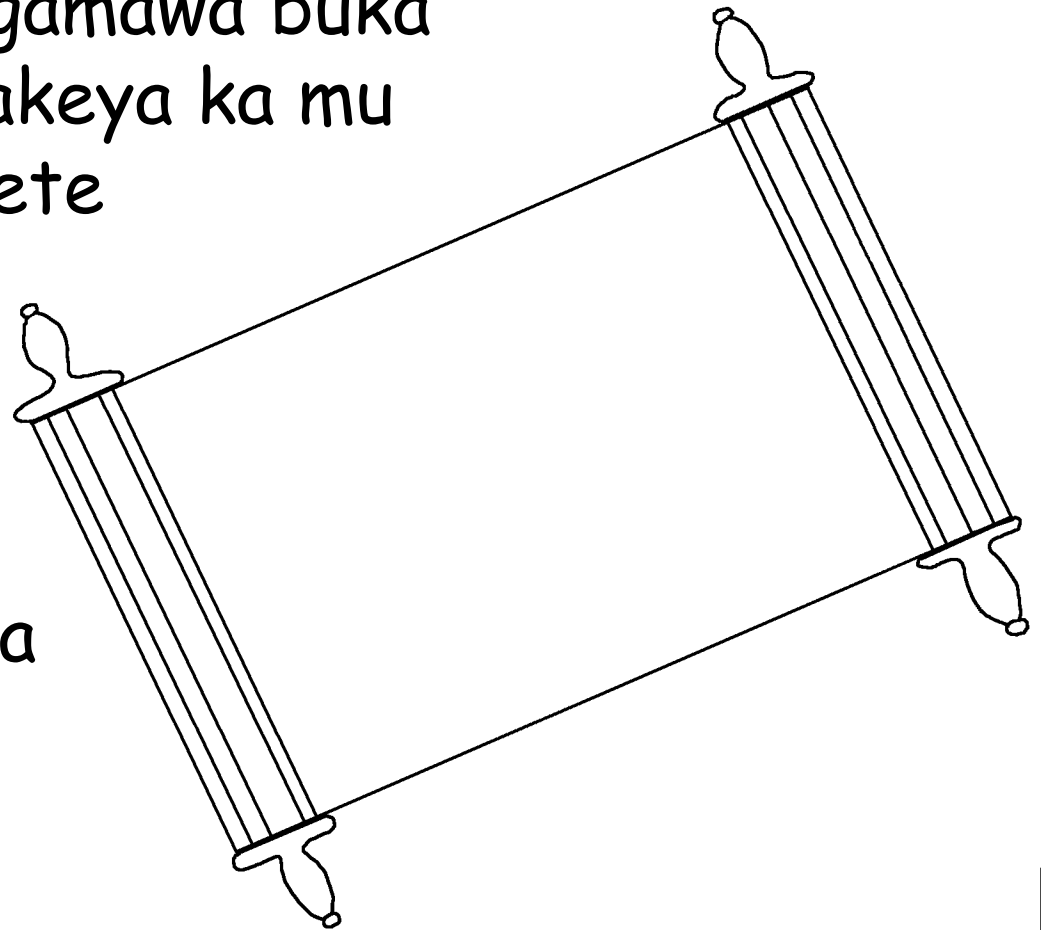

Mamanuga God e Keyai ade e sumapiyamu ragidai ridi maba e uwamana ki nana e nawanai idiwu ki mu tagisi ke; 'Kaiwawonuga, kau baunuwagi.' Ade yona yau wainapiyamu ragidai ki mu mete tagisi ke; 'Kaiwawo-nuga, kau baunuwagi.'



Wi gwedewau takotakoigubu awana gobaga wagau  
bo wi nuwagau awana kubamana wainapiyamu ki wi  
kebomuri Iya Awana ki puyo deni mena wadu-muri  
kubamuri.



Mamanuga  
God e iyapana  
kuduba, madega  
kau-wagau madega posiwagau wi kaway  
daganani nota kwarikwarisinibu ki  
pokere e eya Gubagai eyaka mena wi  
iyaga nene nau tonosinibu da iyapana  
nima nau sumasiniyono ki ka e  
eba giriyagisi poyagisi ko  
maramara tondono  
kaniyono.



Roumi 3:23 Nu kuduba paeremipi bigi kwaigibi ki pokere nu Mamanuga God e gari tagaiya uwama kawayaya idiwei. Nu nubo kasiyaranuga pokaiya e taneya e gari rabineya baigamana da e nu iyaniyana ki yawatai mo pa mena.

Roumi 6:23 Nu bigi kwaigemei ki denai ka nu po bananapamu. Ko Mamanuga God e puyoi deni mena nu negebu ka yau kena; Nu Kaiwawonuga Keriso Iyesu pokaiya ka nu iya maramara idiwana kaiwana ki iyai yadamu.

Iburu 9:27 Mamanuga God wagubu ki pokere nu kuduba po eyaka mena popoigamu manako ki eweya ka nu e yabareya ubumamu manako e idai gurai nu naurinugu nugwadiniyoto ragiragi.



Epeso 2:8,9 Iyesu nu nene inako kwaewena nu wadinibu bagi ki nu sumapemei ki pokere Mamanuga God ubupu iya waunai ki puyoi deni mena nu pa negebu. Ko ki ka eba nu gwede bagi mosi e nene kwaigibi da ki pokaiya e denai iya ki nu negebu. Pa mena. Nu gwede bagi mosi e nene kwaigumpena manako ki pokaiya e denai iya waunai nu negebena ki ka nu nubo sinuga tepampena yabara kawakawara-igumpena. Ko ki ka eba baganai.

Roumi 10:9,10 Iyapana nima e umunui pokaiya matarau wagau ke, 'Iyesu e ka nau Kaiwawoni', ade e nuwai notai eyaka mena sumapiyau da Iyesu e ka powena ko Mamanuga God e ade iyapupu kipu ubupu, iyapana nima inako notapiyau ki ka e iya waunai yadini.



Nu nuwa-nuga notanuga pokaiya sumaigemei ki pokaiya ka Mamanuga God nu iyapana bagi supasupai nidiyau. Ade nu nubo umununuga pokaiya iwegemei da 'Iyesu e ka nu Kaiwawonuga', nu inako iwegemei ki pokaiya ka e iya nu negeyau.

Diyoni 3:16,17 Mamanuga God e iyapana kuduba, madega kau-wagau madega posiwagau wi kawaya daganani nota kwarikwarisinibu ki pokere e eya Gubagai eyaka mena wi iyaga nene nau tonosinibu da iyapana nima nau sumasiniyono ki ka e eba giriyagisi poyagisi ko maramara tondono kaniyono. Mamanuga God ubupu nau tonosinibu kawapuwani ki ka nau iyapana kuduba wi iya waunai negeyana ki nana bausugubuwani ko eba nau idani gurai wi naurigau ugwa-diniyana ragiragi ki nana bausugu-buwani.



1 Diyoni 5:11-13 Ki pokere yona mibai ka yau kena; Iya waunai maramara idiwana kaiwana ki iyai ka Mamanuga God e Gubagai pokaiya nu negebu. Iyapana nima Mamanuga God e Gubagai sumapiyau ade wadubu e eya iyai rabineya tapu ki ka maramara idiwana kaiwana iyai ki e wadubu kewowena. Ko iyapana nima Mamanuga God e Gubagai eba suma-piyau ade e eya iyai rabineya eba tapu ki ka maramara idiwana kaiwana iyai ki e eba wadubu.

Mununiyoma, wi ka Mamanuga God e Gubagai sumapiyamu ki ragidai. Nau oka yau okapakani mibai ka nau nuwaneya wi naigida mena kataiwagi wetawetara da iya waunai maramara idiwana kaiwana iyai ki wi wadumupu kewowena.



Diyoni 14; 2 Korini 5; Matatapupu 4, 21, 22

Storyline by: Edward D. Hughes

Illustrated by: Lazarus  
and Alastair Paterson

Adapted by: Sarah S.

Umanakaina NT (gdn) © 2013, Wycliffe Bible  
Translators, Inc. All rights reserved.

<https://live.bible.is/bible/GDNPNG/MAT/1>

©2025 Bible for Children, Inc.

[www.M1914.org](http://www.M1914.org)

[www.bibleforchildren.org](http://www.bibleforchildren.org)

