

[www.BibleForChildren.org](http://www.BibleForChildren.org)



Zuwã 14



Tawamhã Zezusi te duré tãma nhaĩ za'ra, ãne:  
— Aihâtâ'â za'ra wa'aba õ di za. 'Re ihâimana u'âsi  
mono si, te za asina i'umnhasi za'ra wa'wa. Ìzama te  
za duré asina ã'umnhasi za'ra wa'wa, Danho'reptui'wa  
na hã. Ìmama nhorõwa ãma hã rob're za'ëtê di, 're  
idasì'ubumroi  
mono zéb  
da hã.

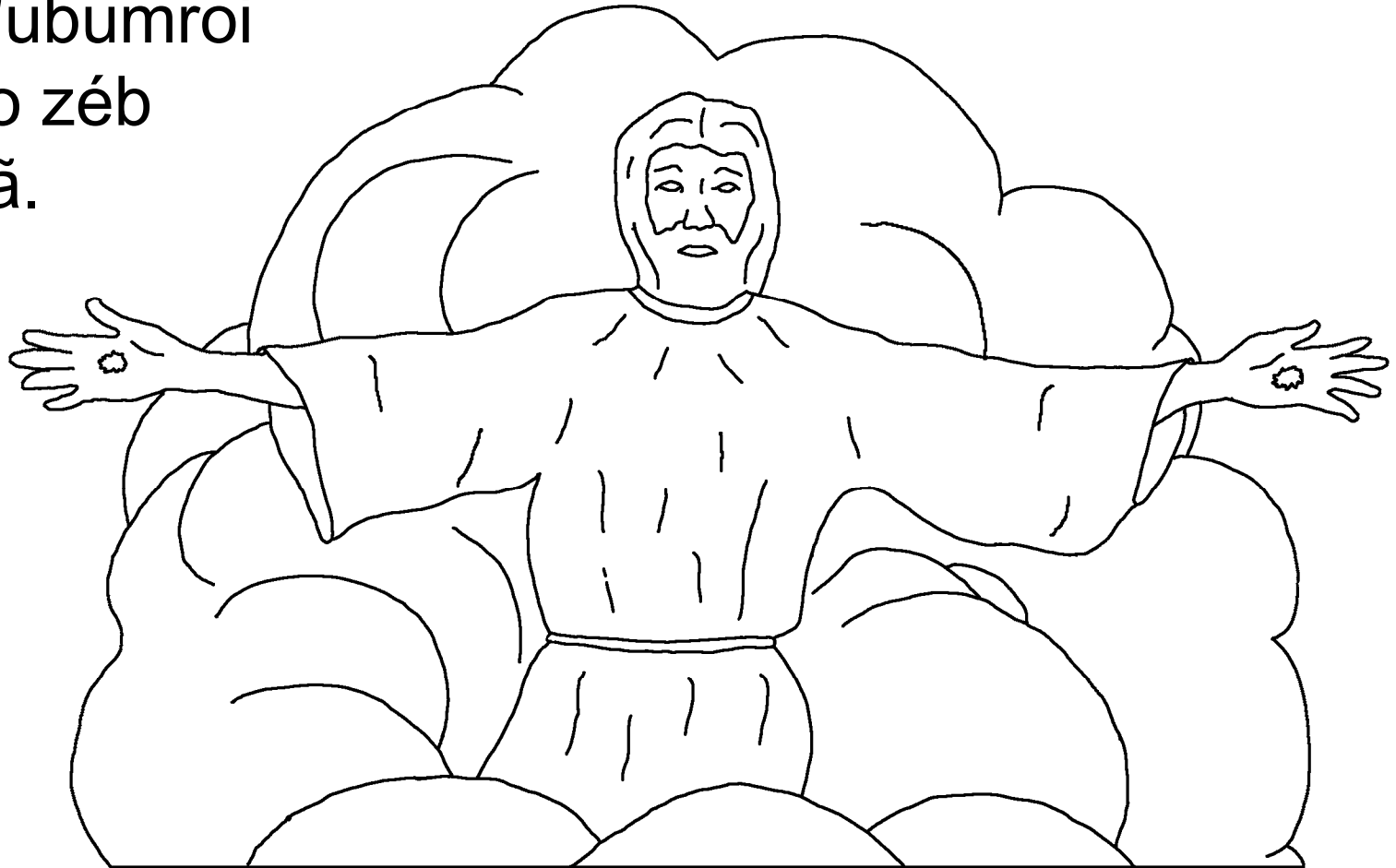

Tame 're idasi'ubumroi mono zéb õ 'wa'âhã, te aré  
aima rowasu'u za'ra wa'aba õ di. Wa za oto aiwi ãmorĩ  
'wa, 're asimroi wa'aba mono zéb da hã, te asô pisutu  
za'ra wa'aba da.



Te asô pisutu za'ra wa'aba parip si, wa za wei mo apâ,  
te ãma asimroi wa'aba mono da, 're ãnhamra mono  
zéb u, tame ãrata 're aihâimana u'âsi za'ra wa'aba  
mono da.

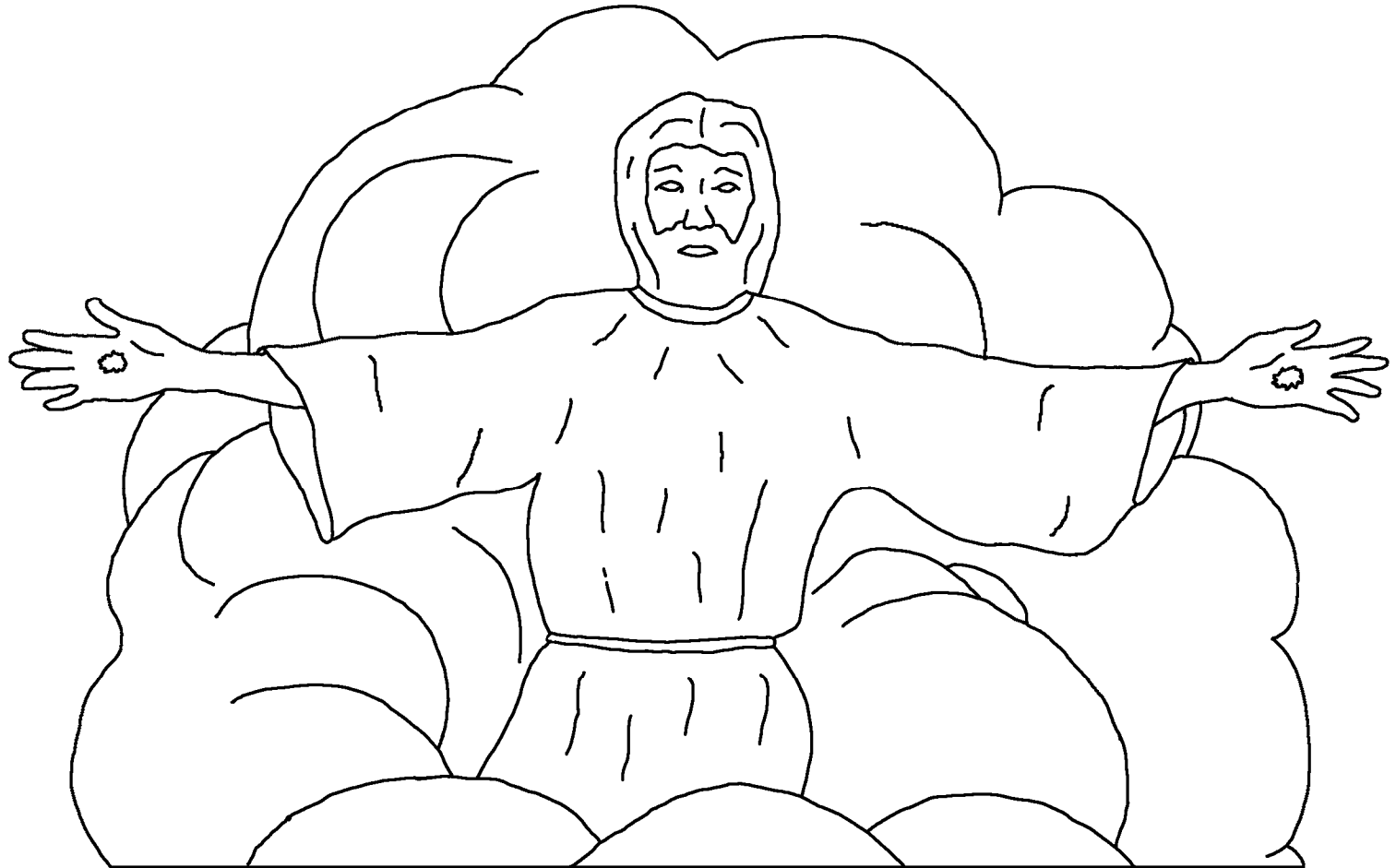

Wa hã Zuwã, asisãnawãï wa'wa. A norĩ wa'wa hã  
Zezusihi ãma si 're anomro aba mono wa,  
danhimirob'manhaĩ wasédé, 're isépata

za'ra wa'aba mono ne, wa  
duré te 're robzépata,



asine za'ra wa'aba,  
Zezusihi ãma si 're  
ĩmorĩ wa.



Zezusihi ãma si wasiré 're wanomro mono  
wa, wa duré 'Re ihâimana u'âsi mono  
nhib'a'uwẽ 're wahâimana za'ra.

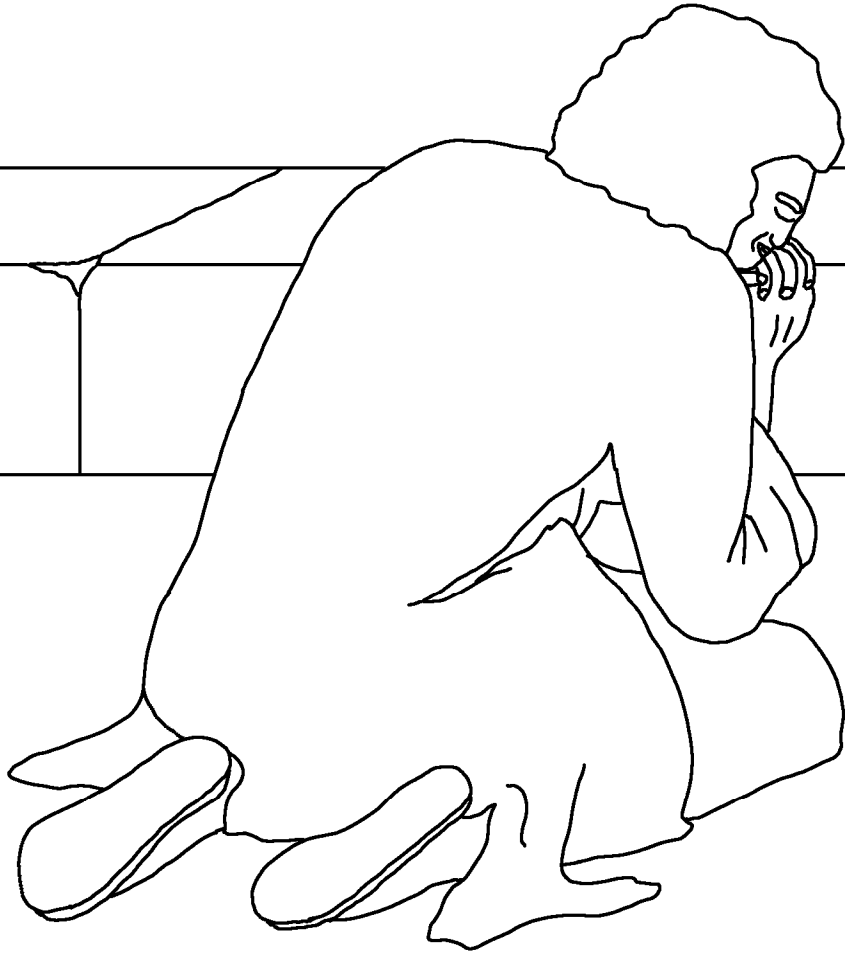

Ta hã te za duré te te 're wa'apawaptob u'âsi, da  
te 're wa'ruiwapari za'ra mono wa, wa te 're  
robzépata za'ra mono nherẽ, wawasété

u tiwi 're wasipizari za'ra  
mono tõi da, wanhiptete

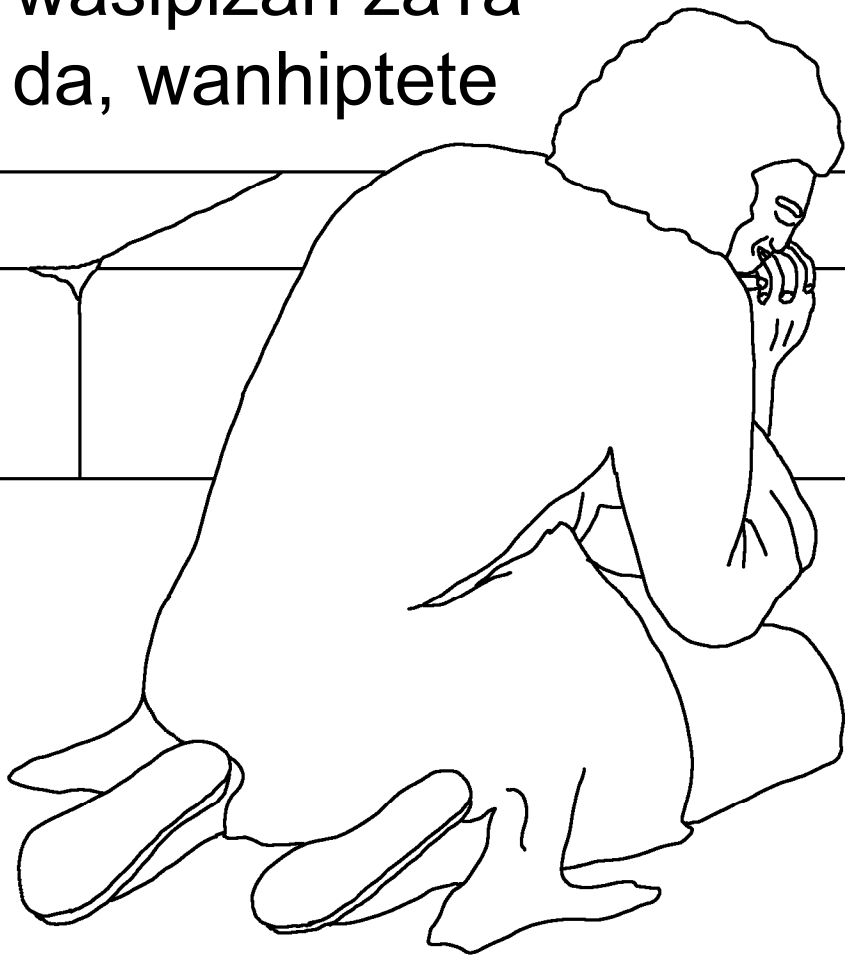

u'âsi ãma 're  
wanomro mono da.



Wa hã wa tô te dama 're sadawa wasu'u, 'Re  
ihâimana u'âsi mono hã. Tô sena na Zezusihi  
zazei'wa na wa tô duré dama 're

ĩsiwasu'u u'âsi. Tahawa,  
ma tô dasiwi ãâri ni.



Tawamhã 'Re ihâimana u'âsi mono pê'êzani hã ma tô  
duré ã'uihã pi'ra, awa'awi. Te te ã'uihã pi'rai wa, wa tô  
duré aimawi ã'hâiba, ã'hâiba waihu'u õ na. Tawamhã ma  
tô ãzaprõ, hãiwa u. Hãiwa u, te te ãzaprõni wamhã,  
danhib'apito  
simasisizé hã wa tô  
'madã. Ni'wa hã  
te ãma nhamra.

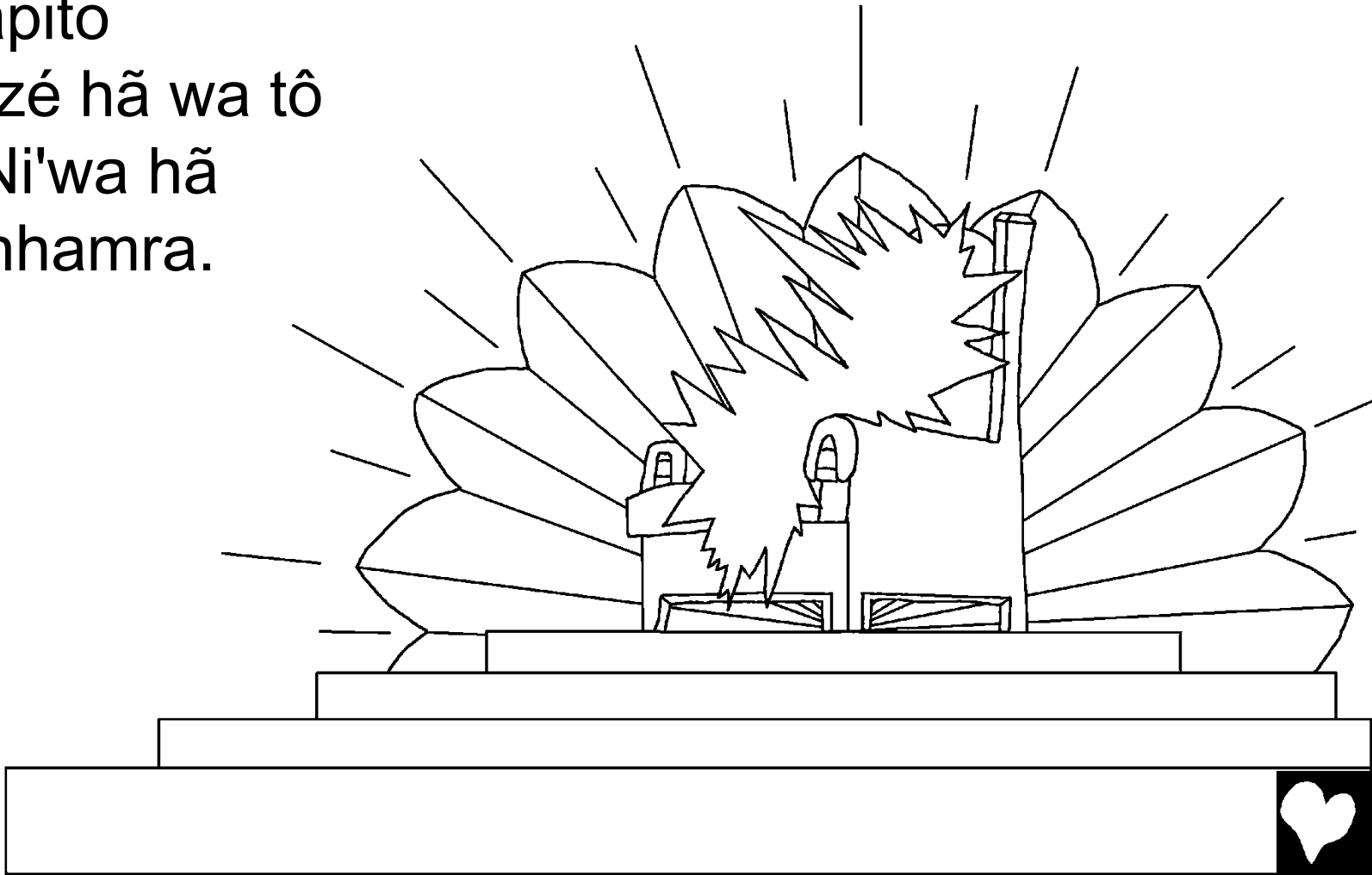

Tawamhã wa tô duré wapa, uburé pese 'Re ihâimana  
u'âsi mono te te ida'apoto mono bâ, duré te te i'apoto  
mono bâ, ihâiba ré mono hã, hâiwa  
ãma, duré ti'ai ãma, duré ti'ai 'rowi  
adâ 're ihâimana za'ra mono zéb  
ãma, duré â 'rowi uburé pese  
ihâiba ré mono hã. Uburé pese te  
simisutu  
dasiwazari  
tazadawa'a'a ni,  
'Re ihâimana  
u'âsi mono te  
te ida'apoto  
mono bâ.

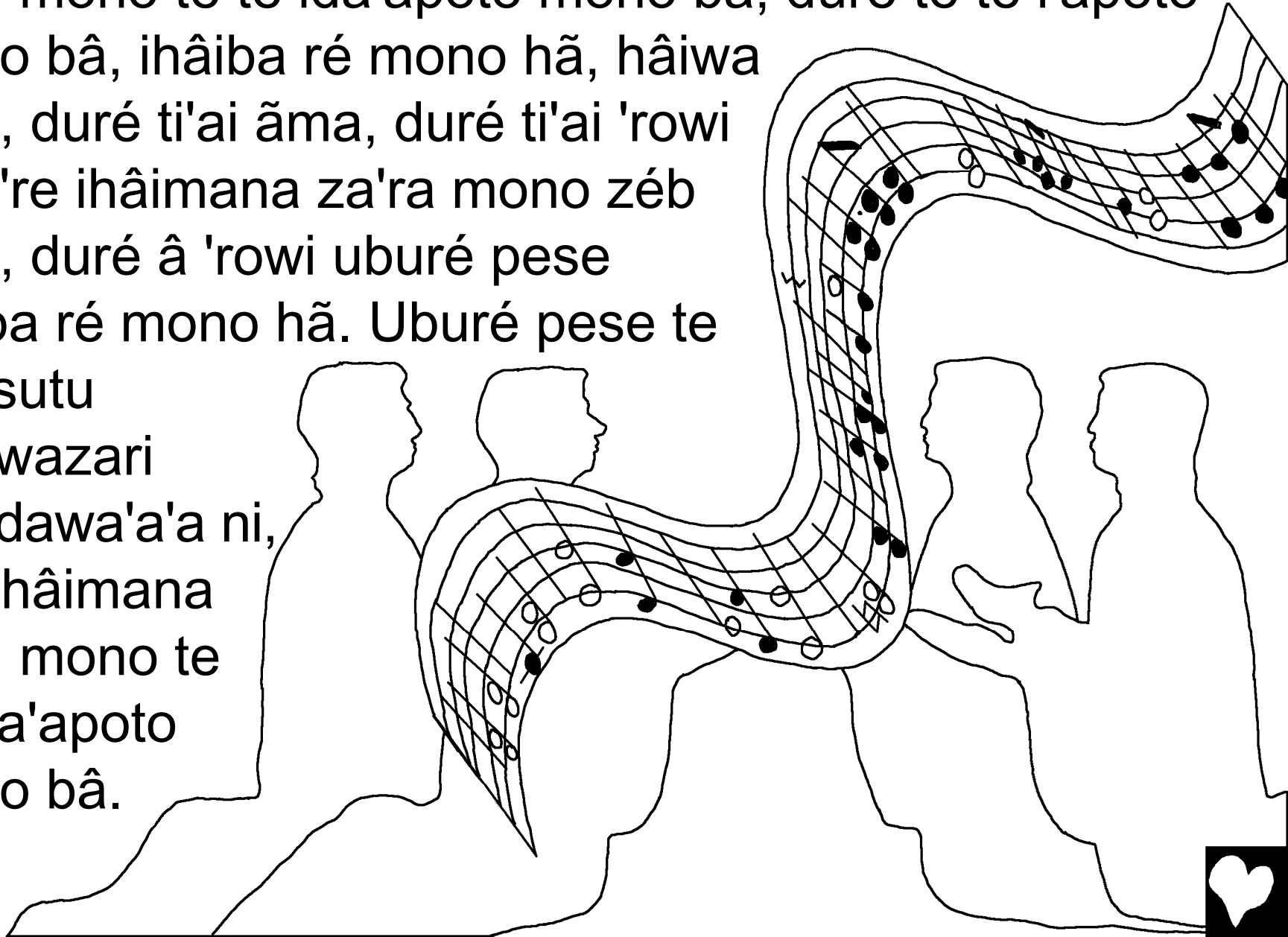

Ãne te tazadawa'a'a ni, ta norĩ hã: “Danhib'apito  
simasisizém na isãmra ãma, 're wawata u'âsi za'ra  
wa'aba mono. Duré Pone'ërebâi  
ãma, 're wawata u'âsi za'ra  
wa'aba mono. Wẽ uptabi zahuré  
wa ta norĩ hã, duré waihu'u pese  
uptabi zahuré  
wa, wa za ãma  
're wawata  
u'âsi za'ra, õ  
norĩ ãma.”

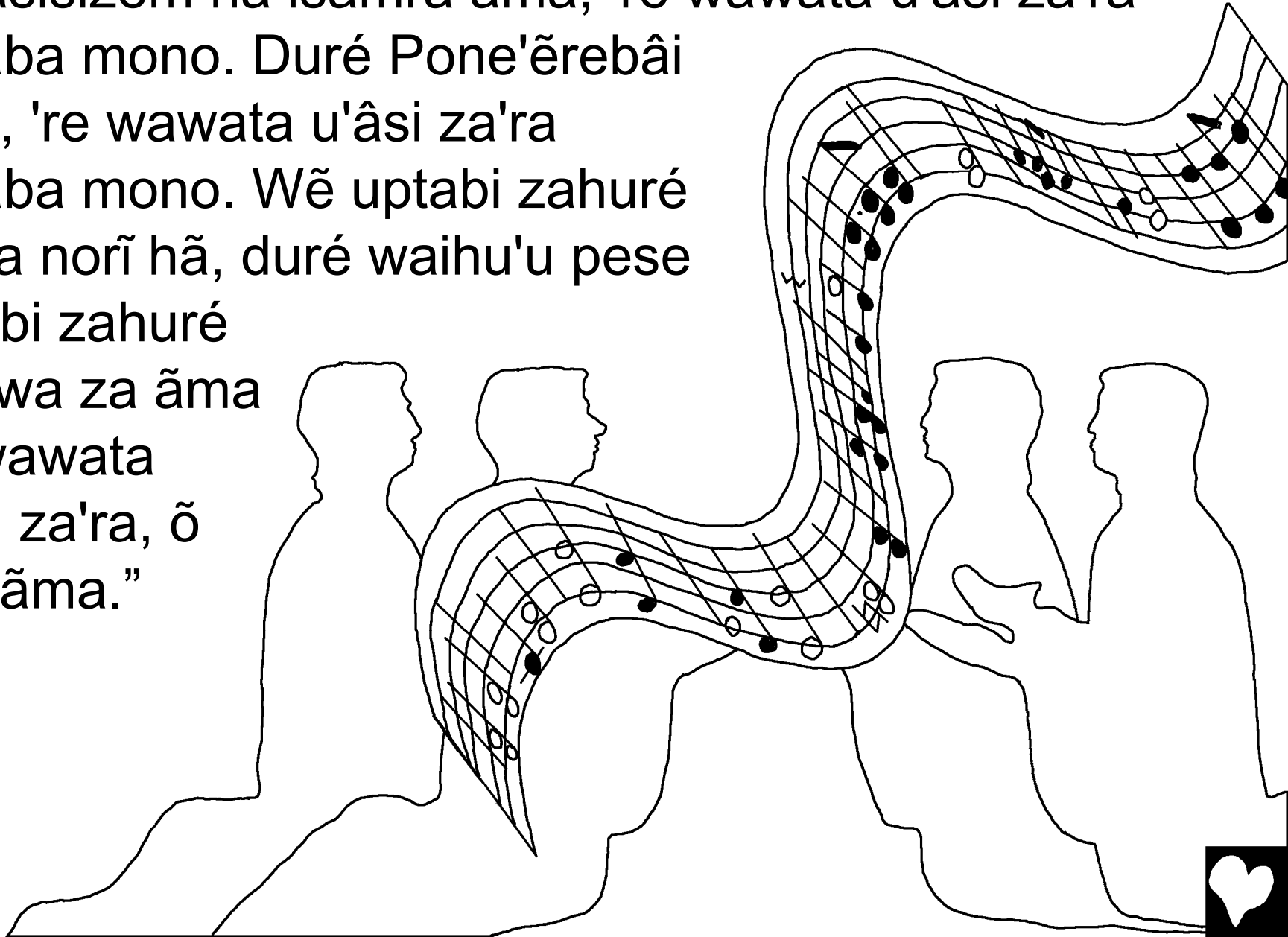

Tawamhã wa tô duré 'madâ, 'ri nho'u hã, iwasédé iwa  
're ihâimana mono õ hã, Zeruzalẽ itém na isisi hã. Ta  
hã te hâiwa hawi wei mo, 'Re ihâimana u'âsi mono  
hawi. Pi'õ hã oto mro da, 're isi'uza wẽ uptabi za'ra  
mono ne, ma we si'ra, 'ri nho'u iwẽ uptabi hã.

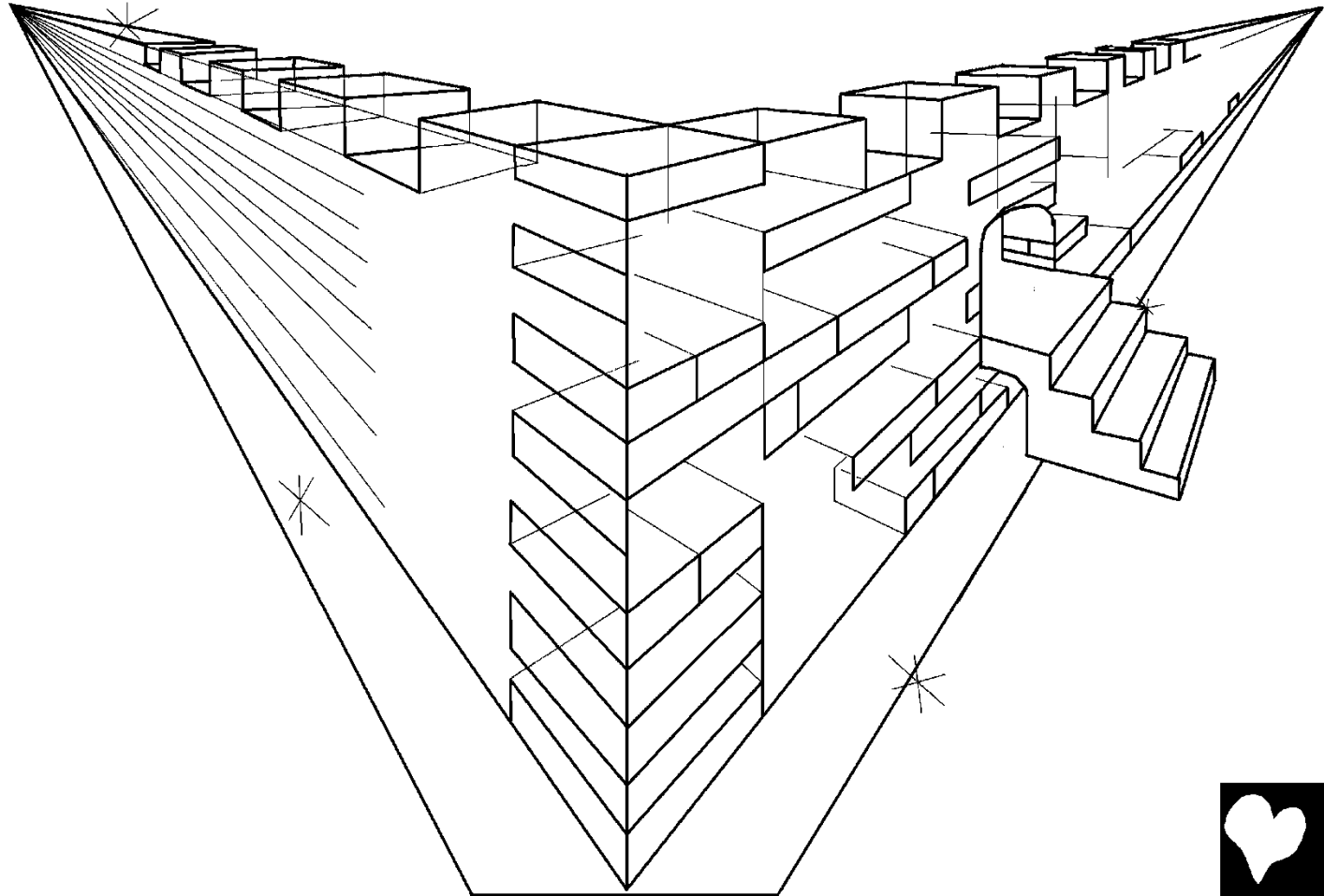

Tawamhã damreme 'rãihã hã wa tô duré wapa,  
danhib'apito simasisizém hawi we te te inharĩ hã. ãne  
te we ĩma tinha: — Ma'ãpé, waihu'u. 'Re ihâimana u'âsi  
mono hã te za oto dasiré 're hâimana u'âsi, 'râwi.  
Isib'a'uwẽ te za oto 're dahâimana u'âsi za'ra. Te za

tô oto duré  
dasiré 're  
hâimana u'âsi.  
Isib'apito za'ra  
te za oto 're  
hâimana, 'Re  
ihâimana u'âsi  
mono hã.

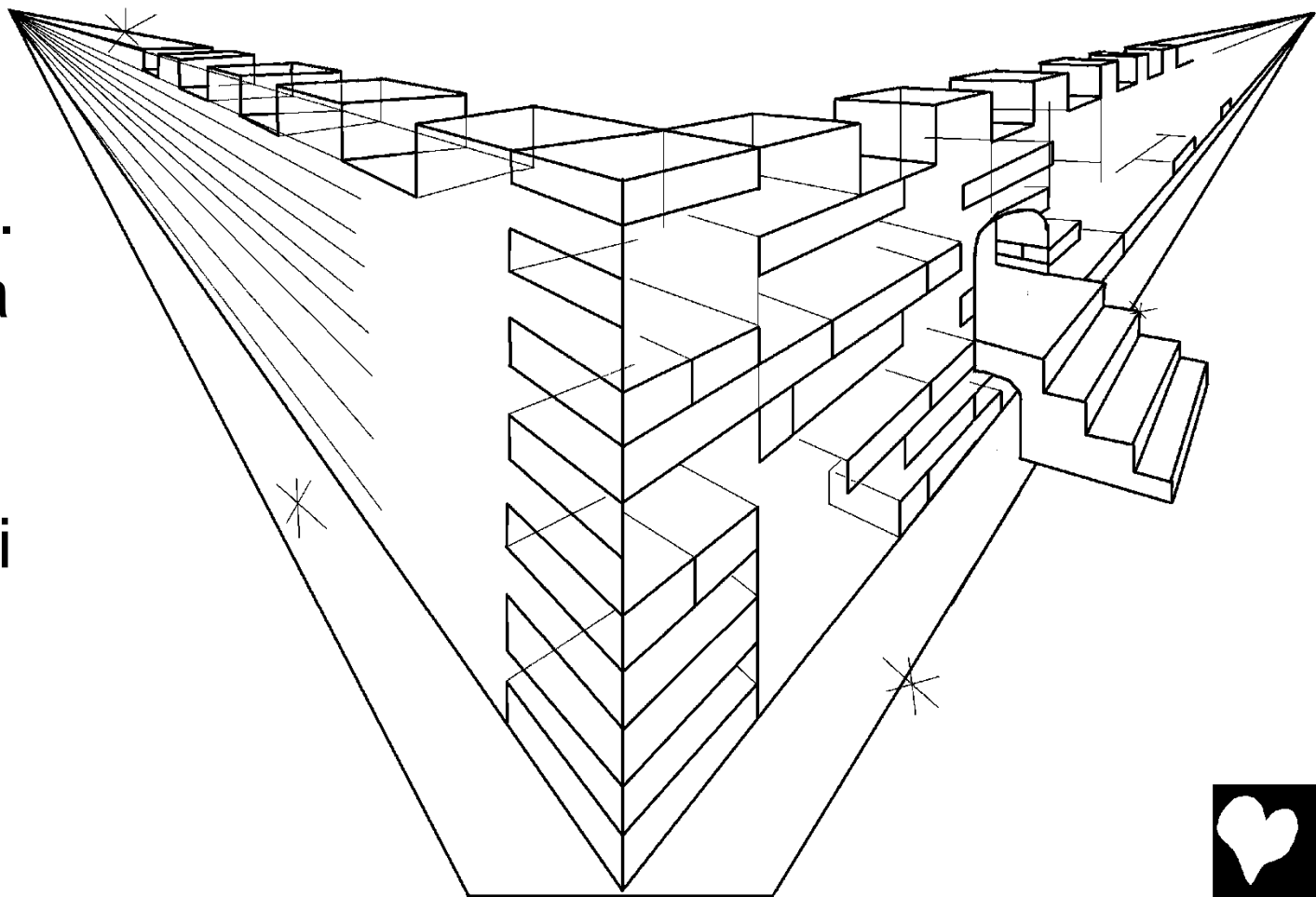

Tawamhã hâiwa ãma 'Re ihâimana u'âsi mono ma romhuri'wa hã, tô õ hã ma tô duré ãzaprõ, â u'â hã te 'madâ'â da. Â u'â hã da te 're âhuri mono wa, dato sina 're idanomro u'âsi mono zé hã. Simhi zarob'a uptabi ne â zarob'a uptabi di, â u'â hã. Panho'u 're ipraba za'ra mono ne, te 'Re ihâimana u'âsi mono norĩ simasisizéb zahâpâ hawi tipraba, Pone'ërebâ simasisizéb zahâpâ hawi me.

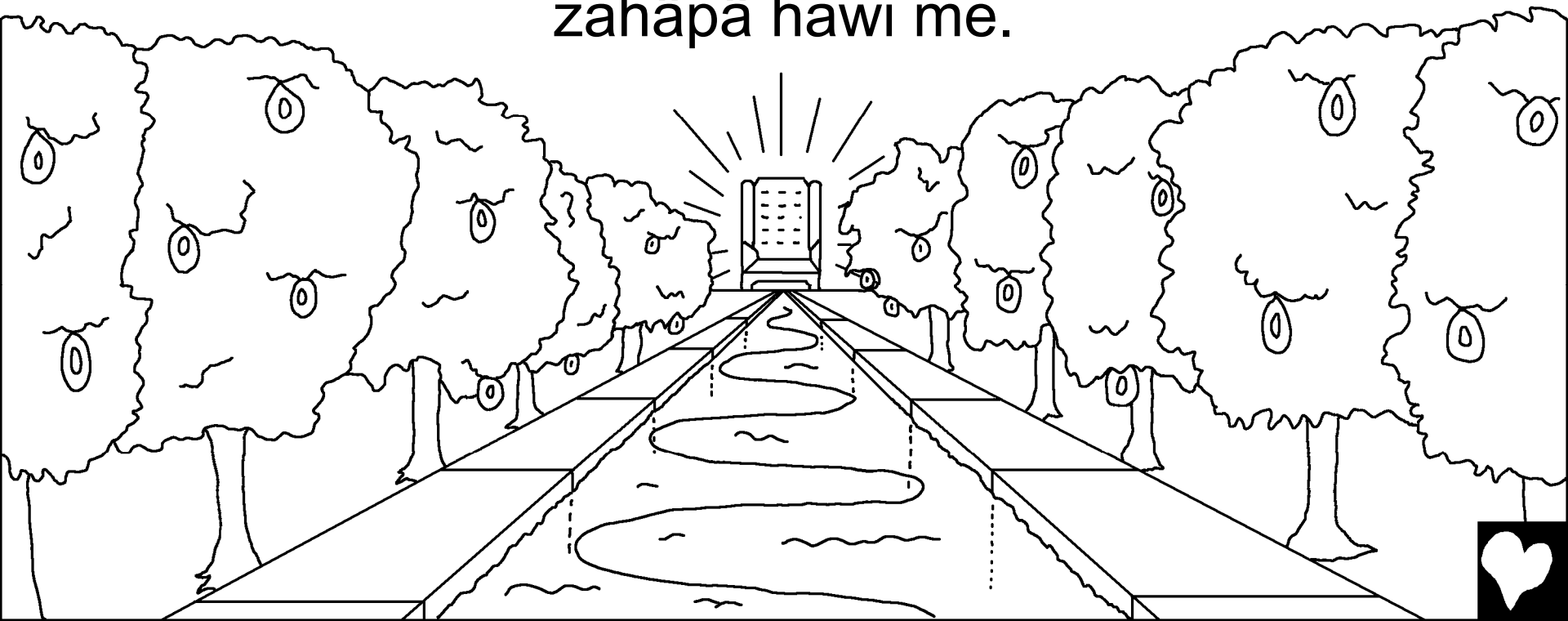

Duré 'ri nho'õmo na hã bådâ te te 're rob'uiwẽ mono õ  
di za oto, duré a'amo zama hã. 'Re ihâimana u'âsi  
mono nhimirowa'a si te za oto te te 're rowa'a,  
Pone'ërebâ nhimirowa'a zama.

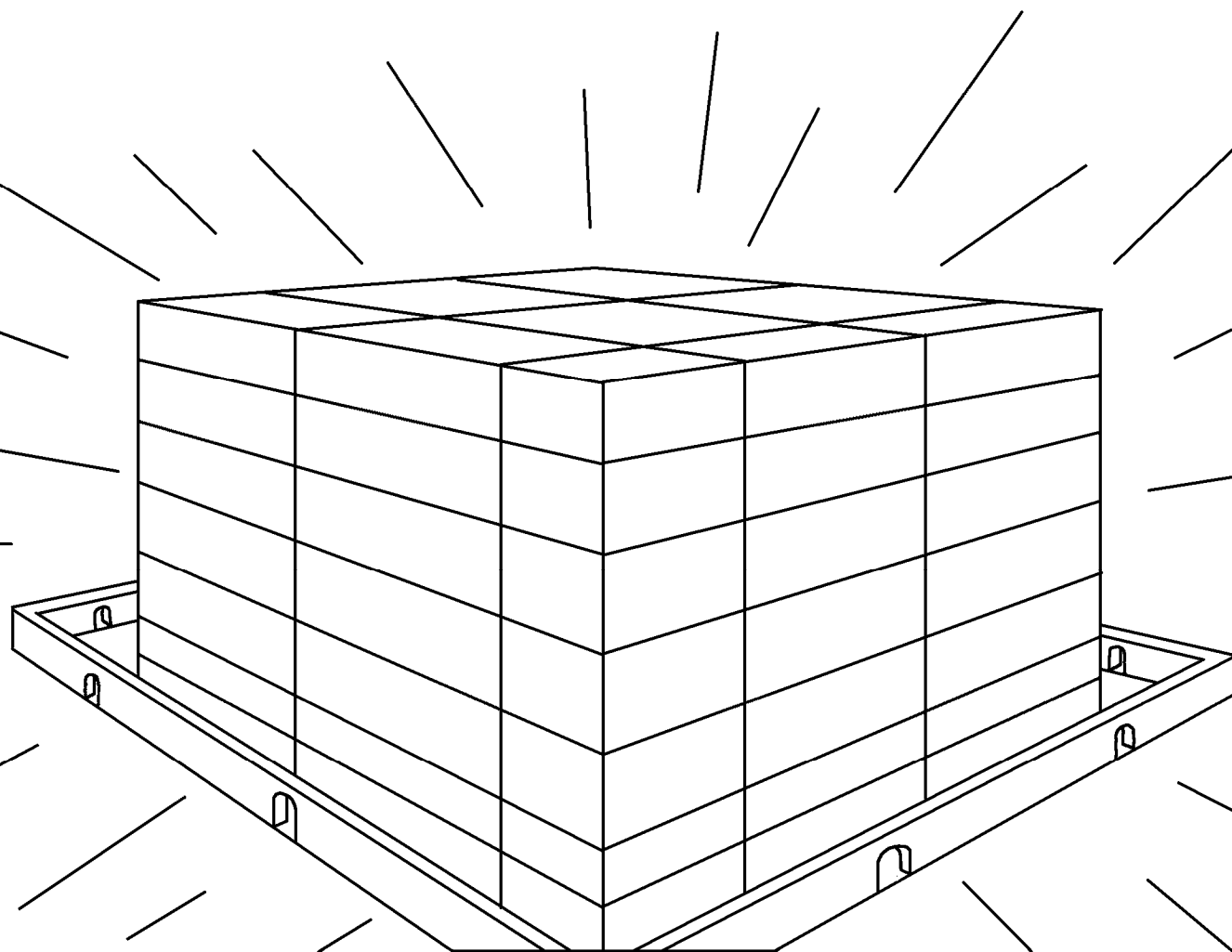

Tawamhã marĩ iwasédé hã da te 'mazasi za'ra õ di za.  
Duré 're idahâimana wasété za'ra mono norĩ hã, duré  
're idazadawa nhipese  
za'ra mono norĩ hã itẽme  
're danhisisi waihu'u  
mono õ di za oto.  
Ibaihã na 're  
idahâimana u'âsi za'ra  
mono norĩ nhisi  
're isimi'wara mono  
zém na, isisi, 're  
isimi'wara mono norĩ si,  
te za itẽme 're sisisi,  
Pone'ẽrebã te na isisi  
ui'éré ré mono norĩ si hã.



— Te za duré oto da'atōmo u'õ,  
dapẽ'ẽzé õ u'âsi 're dahâimana  
u'âsi za'ra mono da. Tawamhã  
duré oto 'Re dadâ'â za'ra mono  
õ di za. Duré 're dasiwa'õ za'ra  
mono õ di za oto. Duré dahâzé,  
da te 're sépata za'ra mono õ di  
za oto. E marĩ wa. Uburé 're  
iromhâimana 'rata mono zé hã  
si'utõrĩ pese wa oto.



Duré marĩ iwasédé hã 'Re ihâimana u'âsi mono te te  
're i'awẽ'õ pese mono hã, iwa 're hâimana za'ra mono  
õ di za, 'ri nho'õmo ãma hã. Duré te te 're ida'awẽ'õ  
pese mono hã iwa 're dahâimana za'ra mono õ di za.



Taha 're te za 'Re ihâimana u'âsi mono norĩ simasisizé  
hã 're hâimana, Pone'ërebâi me iwa 're isimasisi  
zahuré mono zéb da hã, danhib'apito simasisizém ne  
hã, te te ãma 're ida'ab'madâ'â u'âsi zahuré mono zéb  
da hã. Tahawa, te za  
isib'a'uwẽ norĩ hã  
ãma 're wata u'âsi  
za'ra. Te za duré  
i'ubu hã te te siwi  
're 'madâ'â u'âsi  
za'ra. Duré isisi  
na uihâ ui'ééré  
ré, te za 're  
hâimana za'ra.



Tawamhã wa tô duré 'madâ'â za'ra, 're idadâ'â za'ra  
mono hã, dama ipire norĩ hã, duré dama iwapu norĩ hã.  
Da'upsâtã mono bâ, te aihĩni pese danhib'apito  
simasisizém nho're aimasam ni. Â poré mono bâ, â na  
're idasi'utõrĩ mono norĩ zama te aimasam  
ni, adâ 're ihâimana za'ra mono zém  
hawib zama. Tawamhã ibaihã  
ahã na ma tô sõzi  
za'ra ni, ti'ab ré  
uburé marĩ, da te  
're i'manharĩ za'ra  
mono zém na  
rob'ui'ééré ré hã,  
marĩ iwẽ na, duré  
marĩ iwasété na zama.

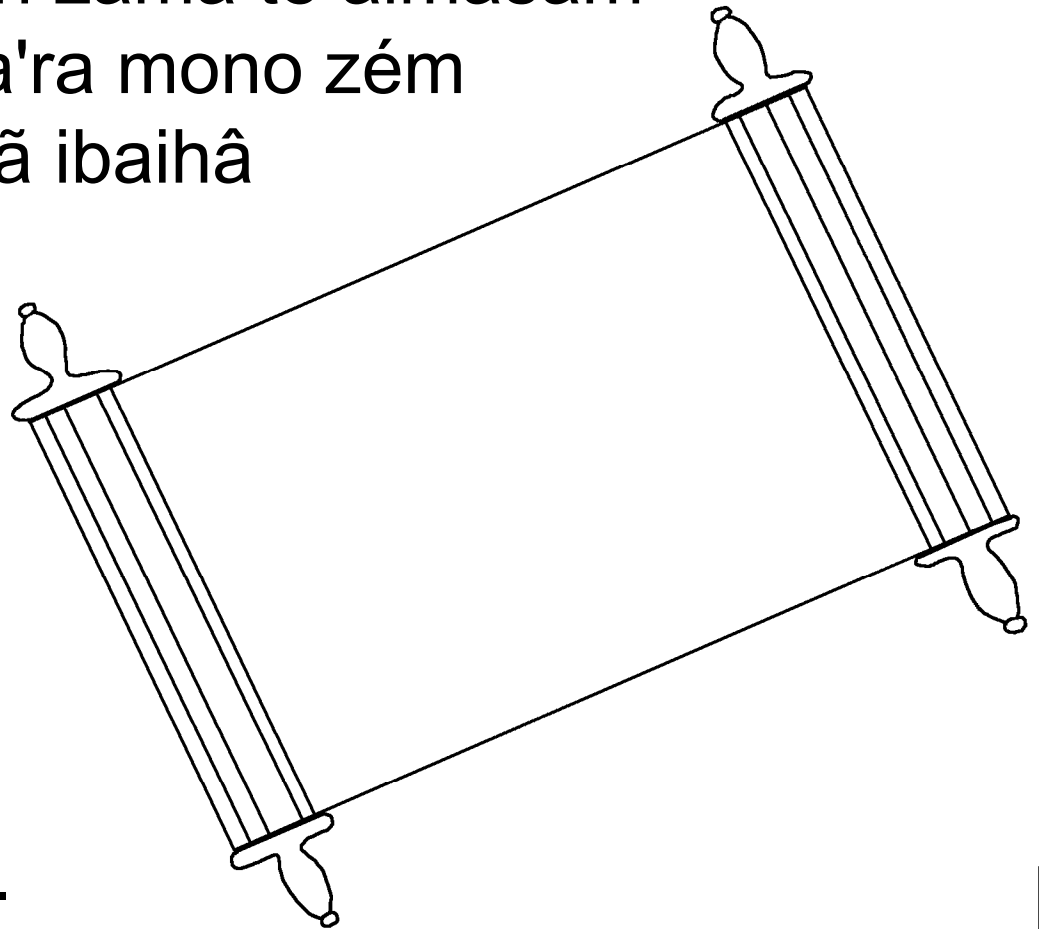

Ma tô duré sōzi ibaihâ hã, 'Re ihâimana u'âsi mono  
'rata za rowẽ na 're idahâimana u'âsi za'ra mono norĩ  
nhisi ré hã. Tawamhã ibaihâ na da te 're i'manharĩ wẽ  
za'ra mono zéb ui'ééré zarina, ma tô da'ãma rowairébé  
za'ra ni. Da te 're i'manharĩ wasété za'ra  
mono zéb ui'ééré zarina zama, ma  
tô aihĩni pese da'ãma  
rowairébé za'ra ni.

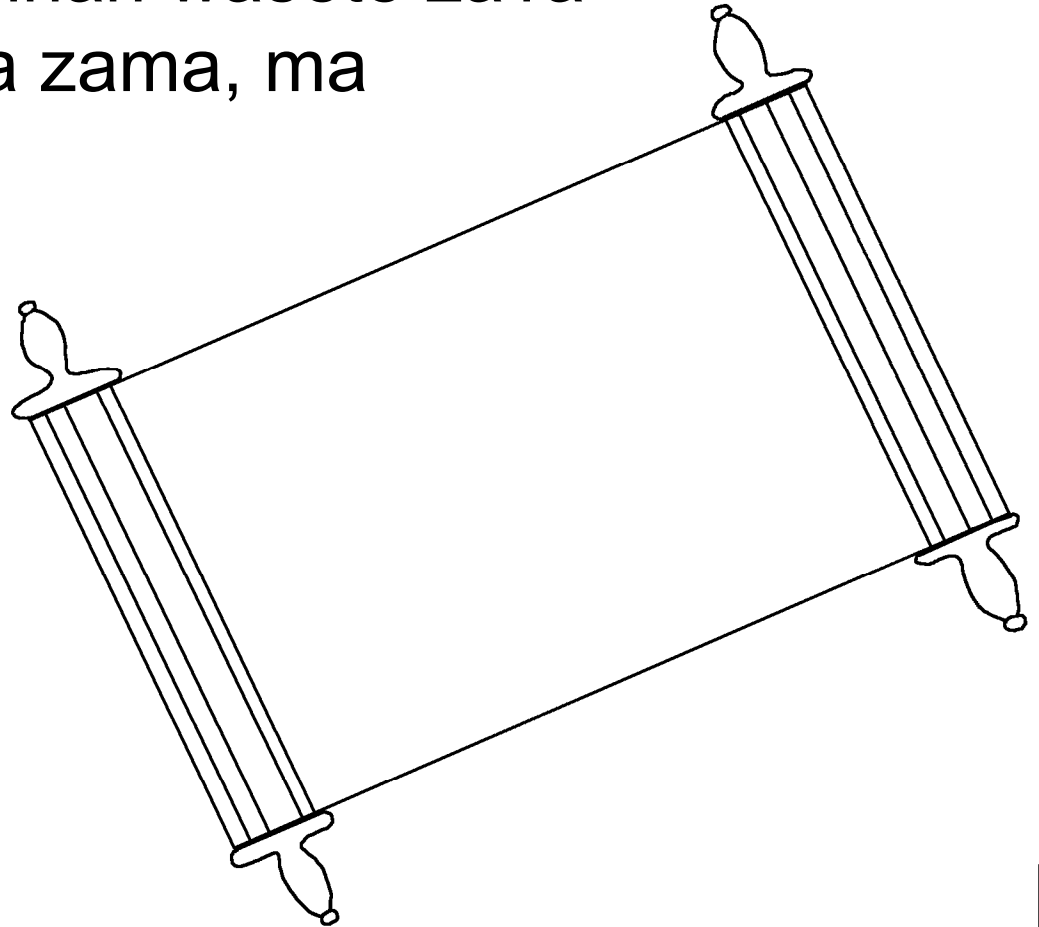

Tawamhã ni'wam norĩ hã ibaihã na 're ihâimana u'âsi  
za'ra mono norĩ nhisi, 're isimi'wara mono zém na isisi  
isimi'wara õ norĩ hã ma tô sãmra ni, unhama ro'o u'âsi  
u. (Ã hã unhama ro'o u'â hã maparane ãma 're idadâ'â  
zahu za'ra mono zé, te wasu'u.) 'Re  
idadâ'â za'ra mono zé hã tâibâ oto.  
Duré adâ hã aré 're ihâimana  
za'ra mono zé hã,  
tâibâ duré oto. Ma tô  
ab're 're sãmra ni,  
uburé adâ'â norĩ hã,  
unhama ro'o u'âsi u.  
Tahawa, tâibâ oto,  
adâ 're ihâimana  
za'ra mono zé hã.

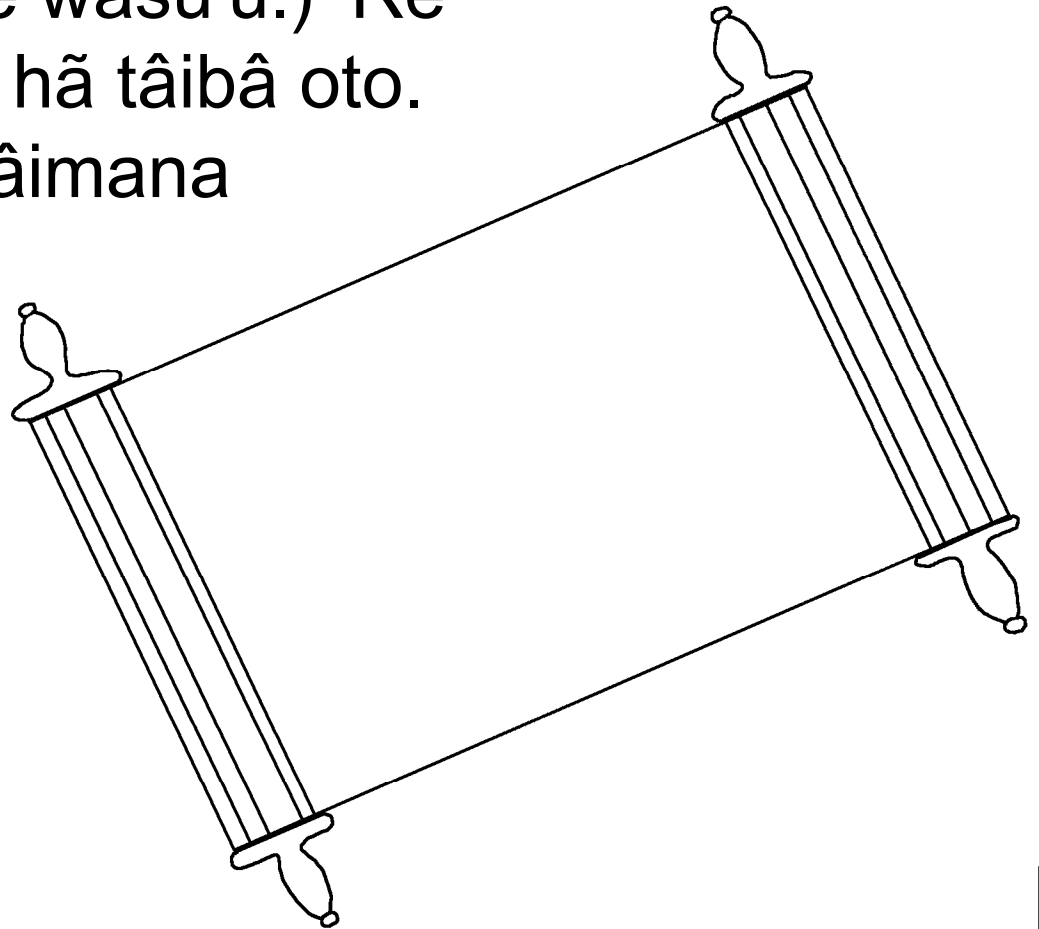

'Re ihâimana u'âsi mono pẽ'ẽzani hã te Pone'ẽrebâi mro da me, dazô 're hârâ u'âsi zahuré, ãne: — We 're anomro aba mono, â u'âsi u. Tawamhã ni'wam norĩ hã ãne hã te te 're wapari za'ra mono wa, â u'âsi u 're nomro mono wamhã, te za duré ihârâ zahuré na dazô 're hãsi u'âsi.

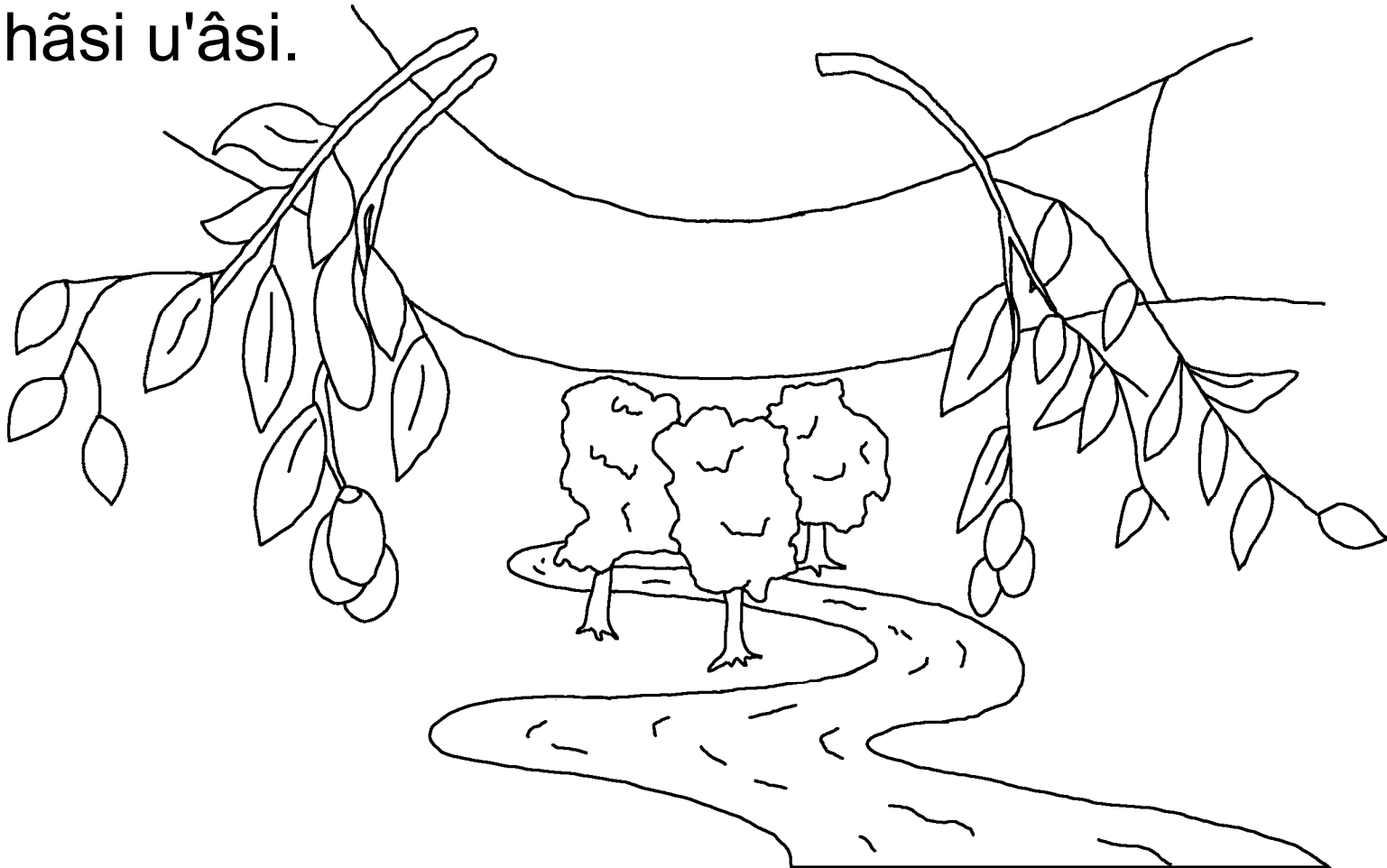

Da te 're 'rubu za'ra mono wa, da te 're i'âhuri mono ne,  
ni'wam norĩ hã te te sima 're wẽ za'ra mono wamhã, te  
za tô â u'âsi u 're nomro, te te 're âhuri u'âsi mono da,  
wa'âbâ ãna. Â u'â hã da te 're âhuri mono wa, 'Re  
ihâimana u'âsi mono 'rata 're idanomro u'âsi mono zé.

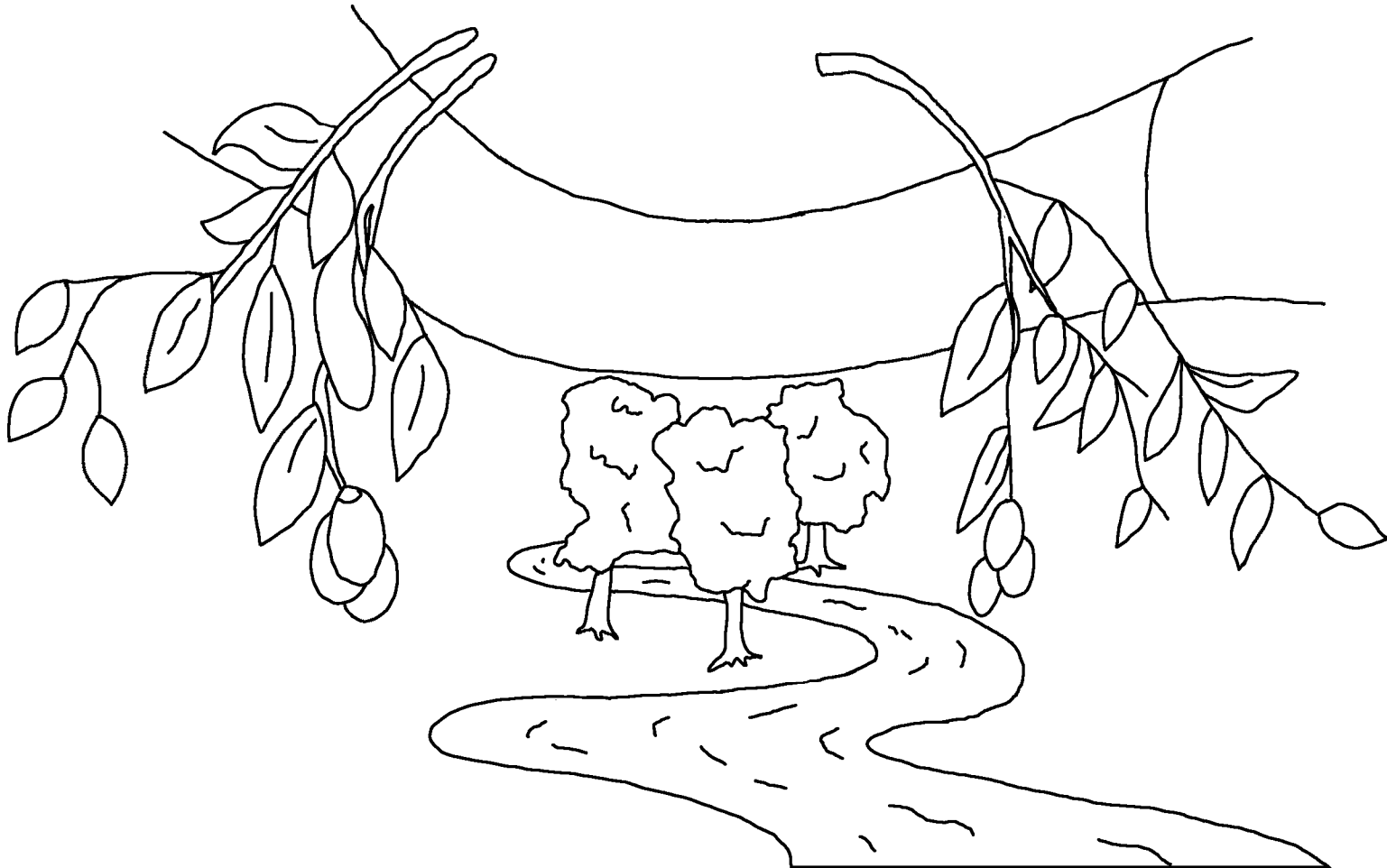

'Re ihâimana  
u'âsi mono ma, tãma dazawi pese uptabi  
wa, ma tô ti'ra hã misi nherẽ, we tisõ,  
dazada dâ'â da. Tawamhã i'ra, da te  
dasina 're umnhasi za'ra mono wamhã,  
dadâ'â ãna te za hãiwa ãma i'rata  
're dasi'ubumroi u'âsi.  
Ropipa ãma isiti 're  
dasi'ubumroi  
mono õ  
di za.



### Roma 3:23

Uburé te dawasété na a'uwẽ mono bâ 're danomro. Tahawa, te 'Re ihâimana u'âsi mono 're imorĩ wẽ uptabi zém nhiti 're dahâimana za'ra, 'râwi da te dasina 're tété waihu'u za'ra mono ãna.

### Roma 6:23

Dawasété na si 're idanomro mono zé wa'rãmi, te za dadâ'â u'âsi ne 're dahâimana za'ra dapẽ'ẽ 're, 'Re ihâimana u'âsi mono nhiti. Wanhíb'apito Cristu Zezusihi ãma si 're danomro mono wapsi, te za 'Re ihâimana u'âsi mono hã sôpru wa, te te dama 're apisutu, i'rata 're idahâimana u'âsi za'ra mono zéb da hã, asa tãma 're idasiwa'âbâ za'ra mono zéb zô, sina 're simnhasi mono ãna.



## Hebreu 9:27

Misi haré te za aihĩni 're dadâ'â za'ra. Taha parip si te za 'Re ihâimana u'âsi mono hã niwapsi da'awaihu'u, dawẽ na duré dawasété na zama, taha zarina te te oto dama 're arowairébé mono da hã.

## Éfézu 2:8,9

'Re ihâimana u'âsi mono te te 're asawi pese za'ra wa'aba mono zéb zarina, ma tô asõ'reptu za'ra wa'wa, Wa'anho'reptui'wa hã asina 're i'umnhasi za'ra wa'aba mono zéb zarina. Asi'uihâ na 're asisõ'reptui waihu'u za'ra wa'aba mono õ di. Sõpru wa, ma tô Wamama hã aima ãma uwaimrami za'ra wa'wa, asõ'reptu za'ra wa'aba zém na hã. Marĩ hã ahâ na 're 'manharĩ wẽ za'ra wa'aba mono nherẽ, taha zarina te te 're asõ'reptu za'ra wa'aba mono õ di za 'Re ihâimana u'âsi mono hã, 'râwi asi'ãma wa'aba 're ai'maiwata aba mono tõi da, asi'uihâ na asi'manho'reptui wa'aba mono dai õ wa.



## Roma 10:9,10

Zezusi hã Asib'apito uptabi na, asadawa na danho'a 're sisi za'ra wa'aba mono wamhã, duré 'râwi aipẽ'ẽ 're, 'Re ihâimana u'âsi mono, Zezusi te te ihâiwa'utuzém na, 're sazei pese za'ra wa'aba mono wamhã, tawapsi te za te te 're asõ'reptu za'ra wa'wa, 'Re ihâimana u'âsi mono hã. Zezusi hã wapẽ'ẽ 're, wa te wasina 're i'umnhasi za'ra mono zém na, 'Re ihâimana u'âsi mono hã te te 're iwa'awěsãmri mono zé hã. Zezusi hã Wanhíb'apito na danho'a, wa te dama 're isisi za'ra mono zém na, 'Re ihâimana u'âsi mono te te 're iwa'anho'reptui mono zé hã.



## Zuwã 3:16,17

'Re ihâimana u'âsi mono ma, tãma dazawi pese uptabi wa, ma tô ti'ra hã misi nherẽ, we tisõ, dazada dâ'â da. Tawamhã i'ra, da te dasina 're umnhasi za'ra mono wamhã, dadâ'â ãna te za hâiwa ãma i'rata 're dasi'ubumroi u'âsi. Ropipa ãma isiti 're dasi'ubumroi mono õ di za. 'Re ihâimana u'âsi mono ma tô ti'ra hã we satõ ti'ai u, te te 're da'anho'reptui mono da. Te te 're da'ahâ za'ra mono da, we te te satõrĩ õ di.



## 1 Zuwã 5:11-13

E niha 'Re ihâimana u'âsi mono hã, ti'ra te te dama 're iwaihu'u mono zé hã. Ta hã ma tô te te wama 're apisutu, i'ra wazada idâ'âzém na ãma 're iwanomro u'âsi mono zéb da hã. Ni'wam norĩ hã 'Re ihâimana u'âsi mono 'ra siré, 'râwi 're nomro mono wamhã, ta norĩ hã te za dâ'â ãna 're hâimana u'âsi za'ra, 'Re ihâimana u'âsi mono 'rata. Tane nherẽ, ni'wam norĩ hã 'Re ihâimana u'âsi mono 'ra siré 're nomro mono õ wamhã, ta norĩ hã i'rata dâ'â ãna 're hâimana u'âsi za'ra mono õ di za. E marĩ da, wa ãne aima rob'ui'éré za'ra wa'wa, 'Re ihâimana u'âsi mono 'ra, asina 're i'umnhasi za'ra wa'aba mono norĩ ma. Aipẽ'ẽ 're, atâ'â ãna 're anomro u'âsi aba mono zém na sena na asina waihu'u pese za'ra wa'aba da, wa ãne aima rob'ui'éré za'ra wa'wa.



Zuwã 14; 2 Corĩtu 5; Apocalipsi 4, 21, 22

Storyline by: Edward D. Hughes

Illustrated by: Lazarus  
and Alastair Paterson

Adapted by: Sarah S.

Xavabte Bible (xav) © 2011, Wycliffe Bible Translators, Inc.  
All rights reserved.

<https://www.bible.com/bible/683/GEN.1.XAVBP>

<https://live.bible.is/bible/XAVTBL/MAT/1>

©2026 Bible for Children, Inc.

[www.M1914.org](http://www.M1914.org)

[www.bibleforchildren.org](http://www.bibleforchildren.org)

