

www.BibleForChildren.org

San Juan 14

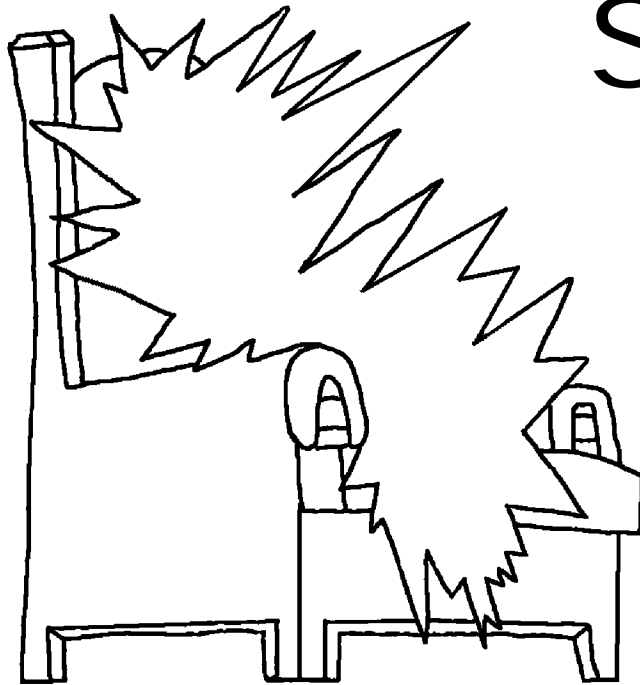

Bi gakshejlall'le. Li gonlilall' Chioza' na' lekzka' li
gonlilall' nad'. Lill xlatj Xa'na' dii xen latj de. Shel' bi
nakan ka', ba wnia' le' ka', shel'ka'. Na' naa yiyaa
Ijayenshawaa gana' yidzoale. Na' kat' ba benschawaan,
na'ch yiyed' yidxia' le' kwençhe lenle soale gana' zoa'.



Na' daa chyixji'a xtil' Chioza' na' xtil'
Jesucrístona' bengake' nad' pres na'
bseġ'gake' nad' yell-liodo'ni le Patmos,

dga Iia lo niso'ni.

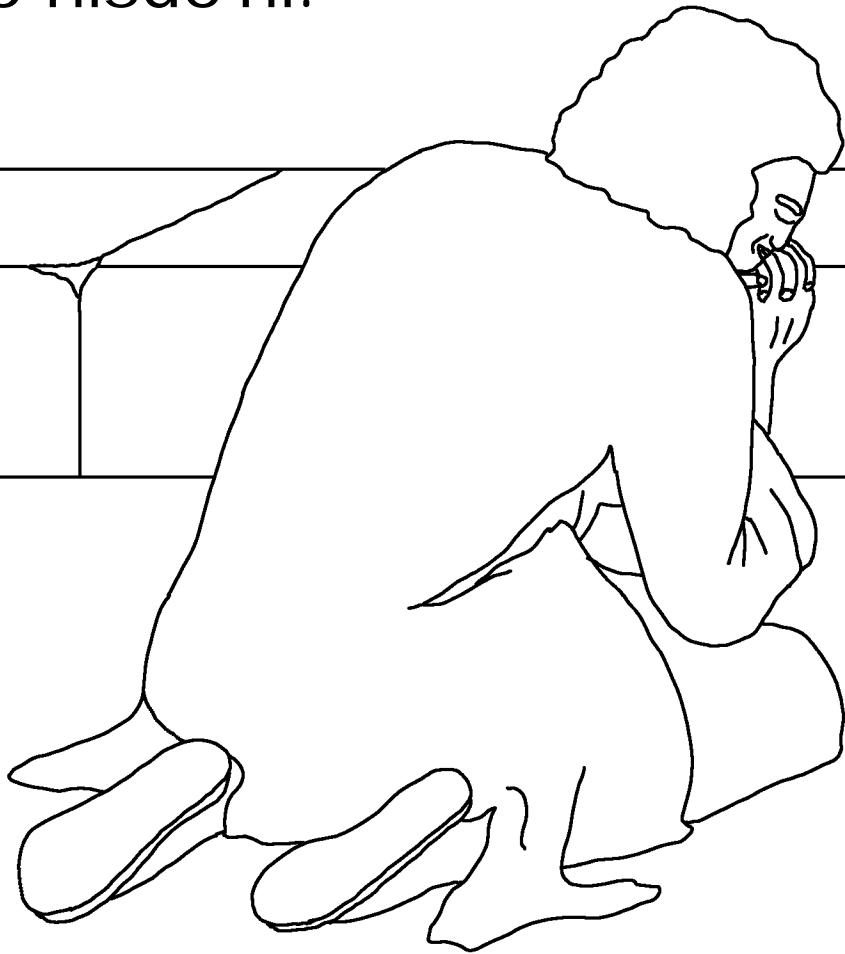

Na' ka wnie' nad', Espíritu çhe Chioza' bene' ka ble'id'
yabana' gana' Iliá to ben' chnabi'e.

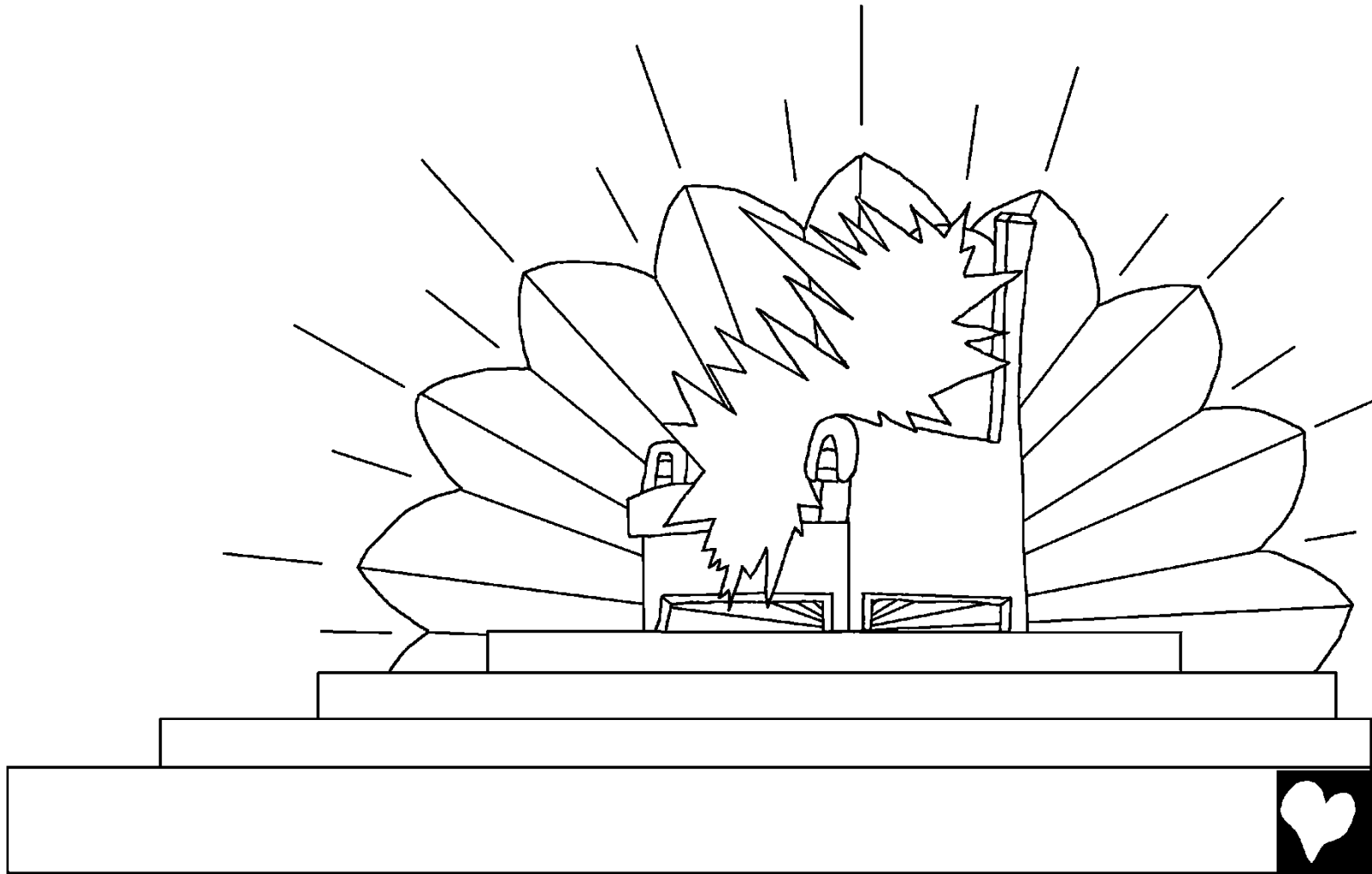

Na' benid' w_{ne} yog'lo_l dii de yel' mban cheyin na' yog'lo_l
diika' b_xe bsil Chioza' yabana' na'
yell-lioni, na' xan yell-lioni, na'
loo nido'na', nagakan: Beena'
Ilia ch_nabia' len beena' nak
ka xil'do',

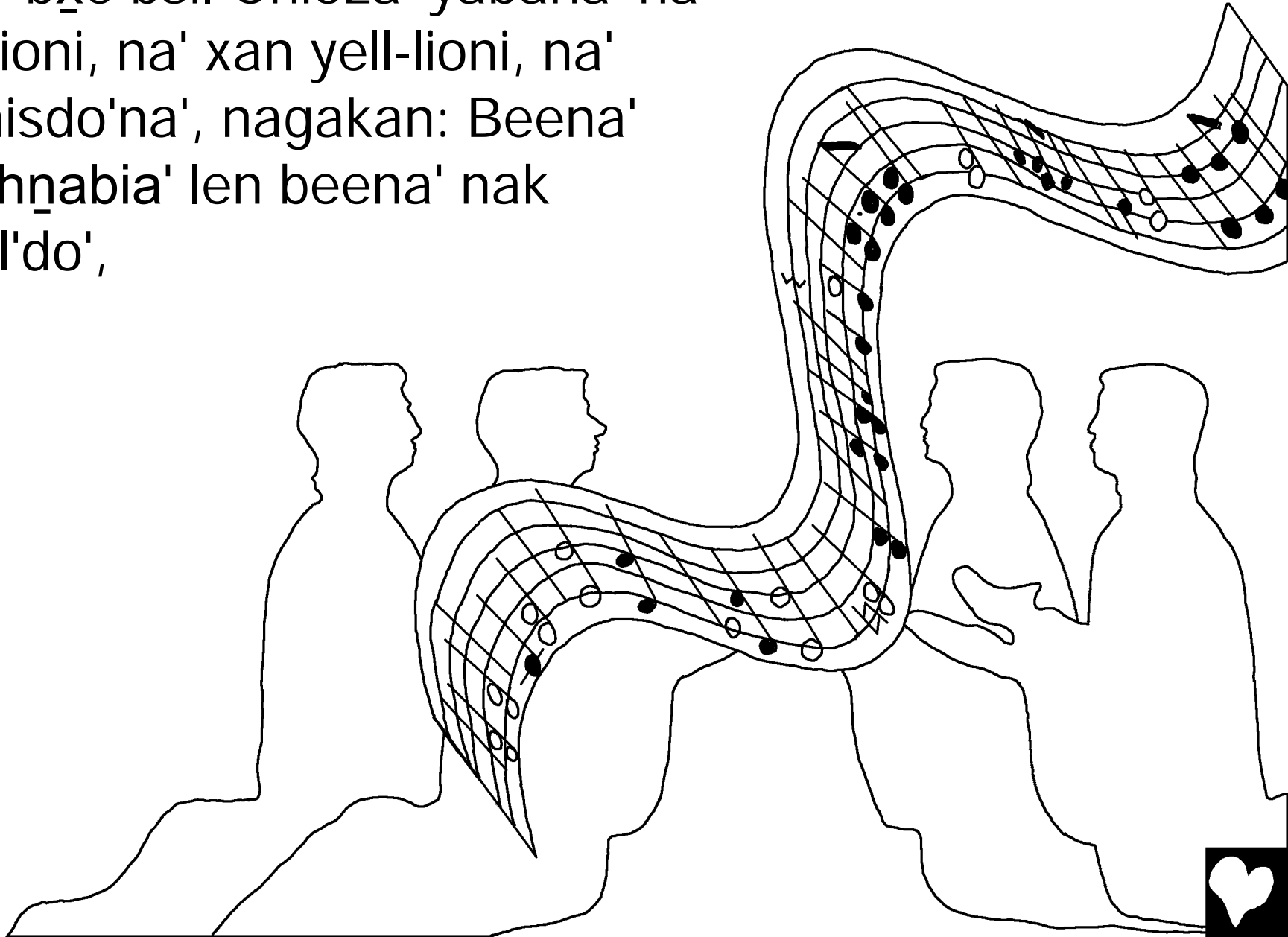

chidoḷ'gake' we'la'ocho ḷegake' na' koocho ḷegake'
balaan̄ zej̄li kani, na' we'cho xtil'gake'
nakgake' beṅ' zakii nḷleb, na'
napgake' yeḷ' wak choo
yeḷ' wak xen.

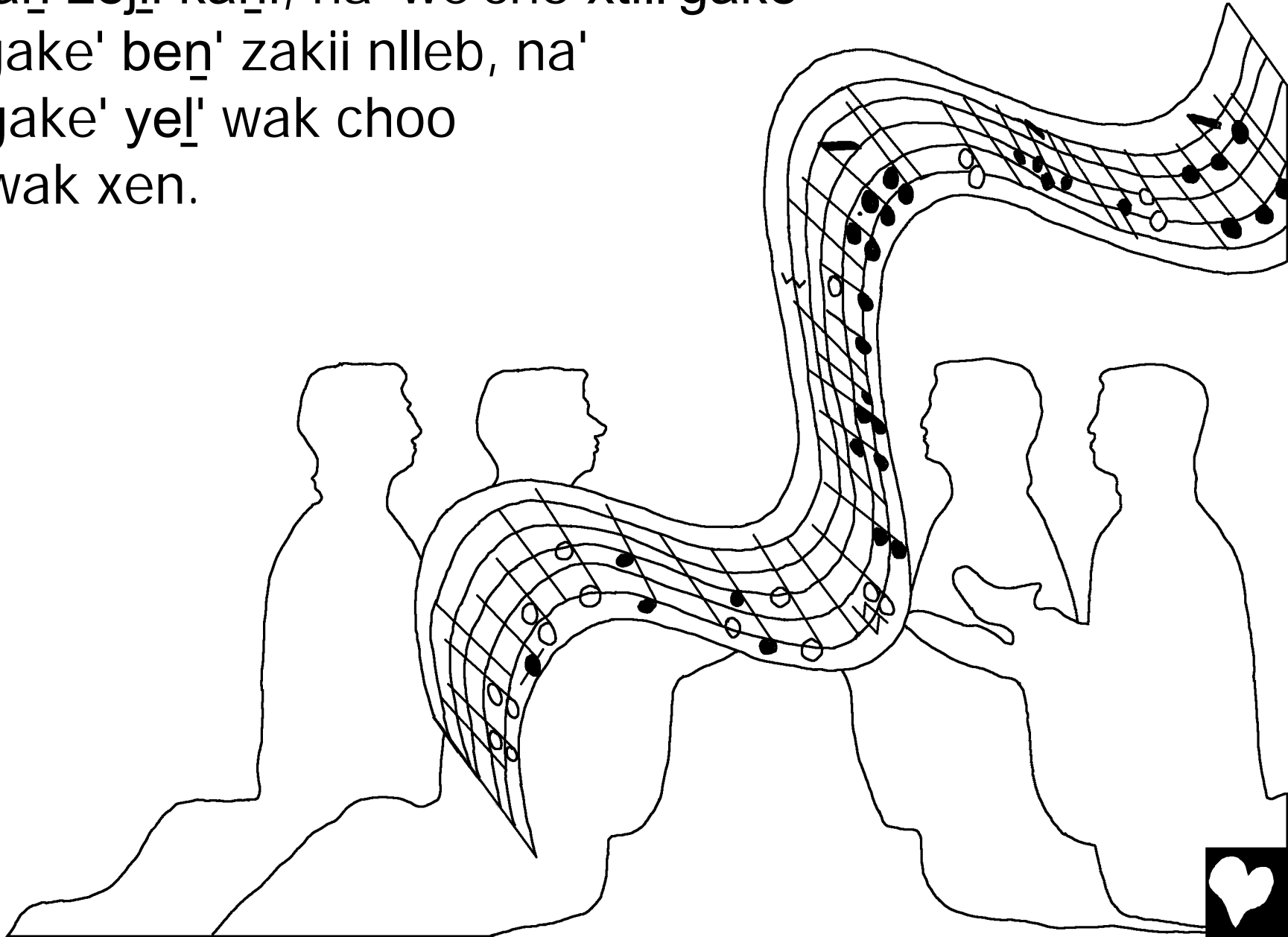

Na' ble'id' yell çhe Chioza', yell koba' le Jerusalén
chetjan yabana' gana' Iia Chioza'. Ba none'n xochi ka
to noolə ben' ba nakwe' xe'na' kwençhe wshagna'lene'
ben' çhe'na'. Na' gana' Iia beena' chnabia', benid' wne
to ben' zillj inleeb, ne': –Chioza' ba

zoe' ladj ben'
yell-lioka' naa.

Na' soalene'
legake', na'
gakgake' yell çhe',
na' kwın Chioza'
soalene' legake' na'
we'la'ogake'ne'.

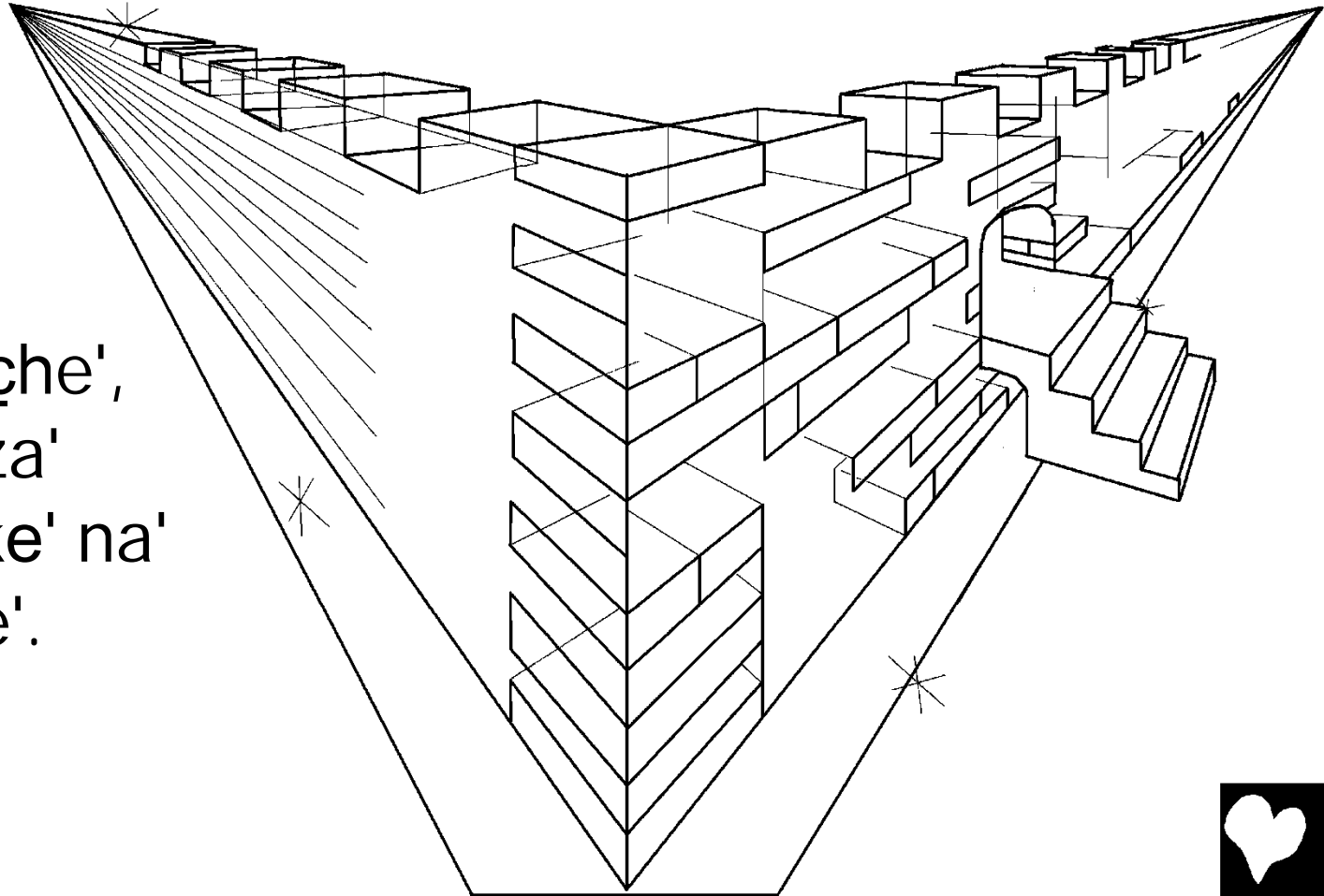

Na' bli'yi anjla' nad' to yao dii nxi nyech yollan nis daa
nsa' ye! mbanna', na' nakan nis xtil inleeb ka'kzə vidr.
Na' chchejan gana' Iia Chioza' chḡabi'e len
Jesucrístona', Beena' Zaklebi to Xil'do', na' chden gcho!
neza' daa chde yella'.

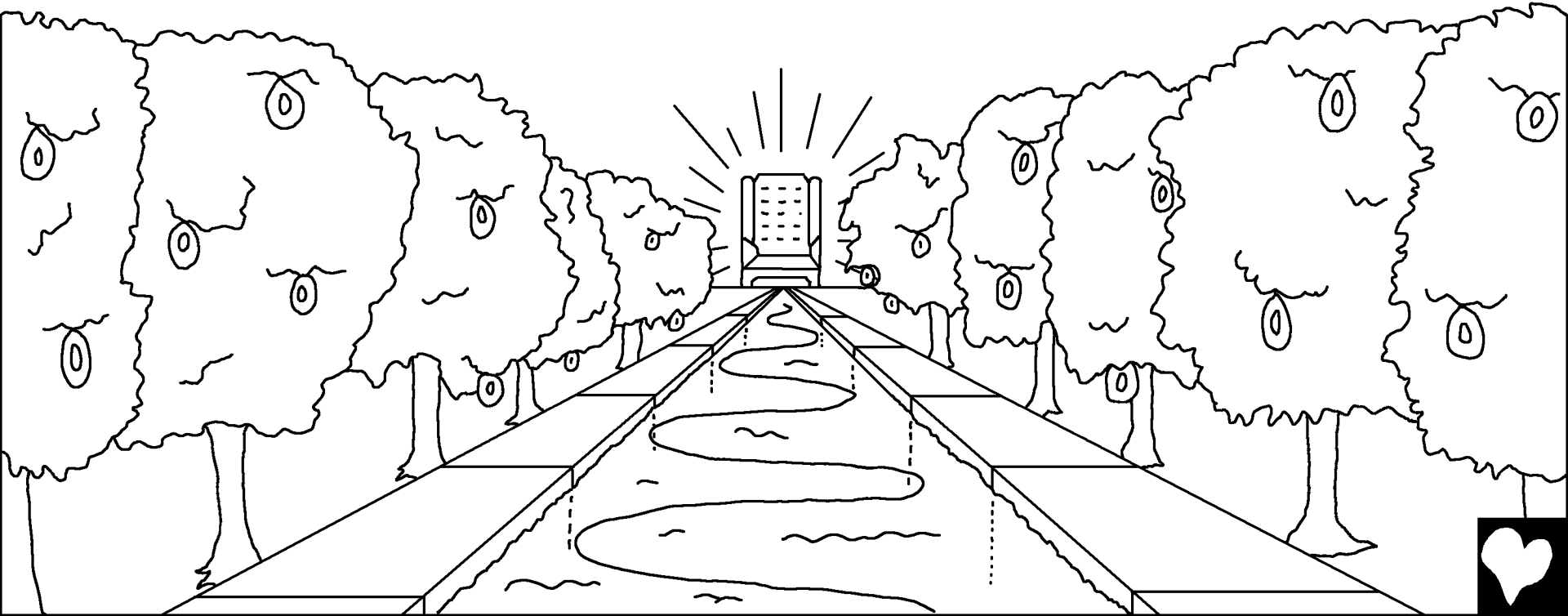

Na' yella' bi byalljin wbilla' ni beo'do'na' kwenche
wzeeni'gakan lawinna', la' ye! chey cheeni' che Chioza'
na' che Jesucristona', Beena' Zaklebi to Xil'do',
chzeeni'n lawinna'.

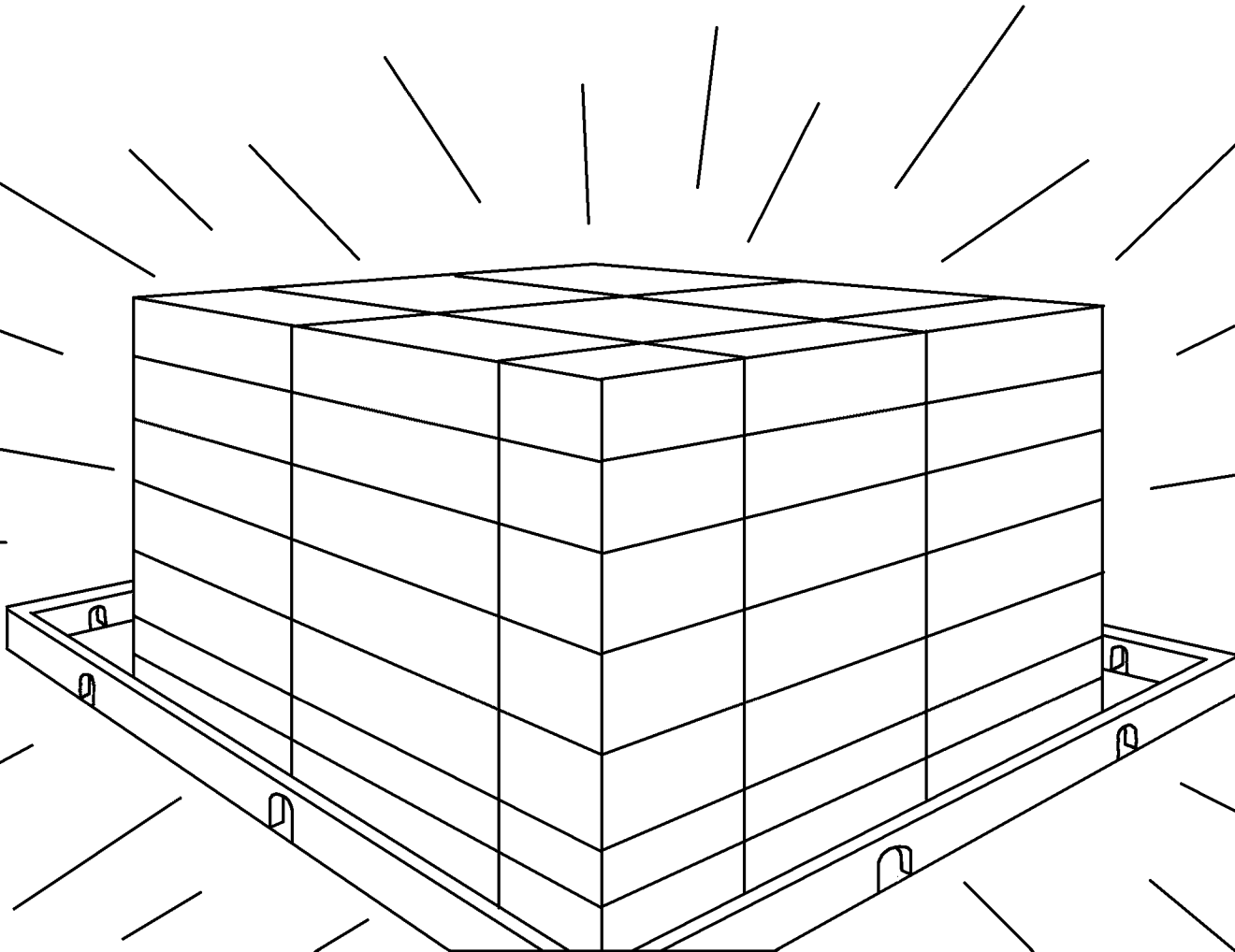

Na' biga sho' ni to dii nda' nchen dii mal, ni
nottez beṅ' chon dii chakzbani
Chioza', ni beṅ' chziye', san
toz beṅ'ka' da' lie'ka' lee
libr che Beena' Zaklebi
to Xil'do', gana' da' le
beṅ'ka' de yeḷ' mban
cheyin zejli kaṅi.

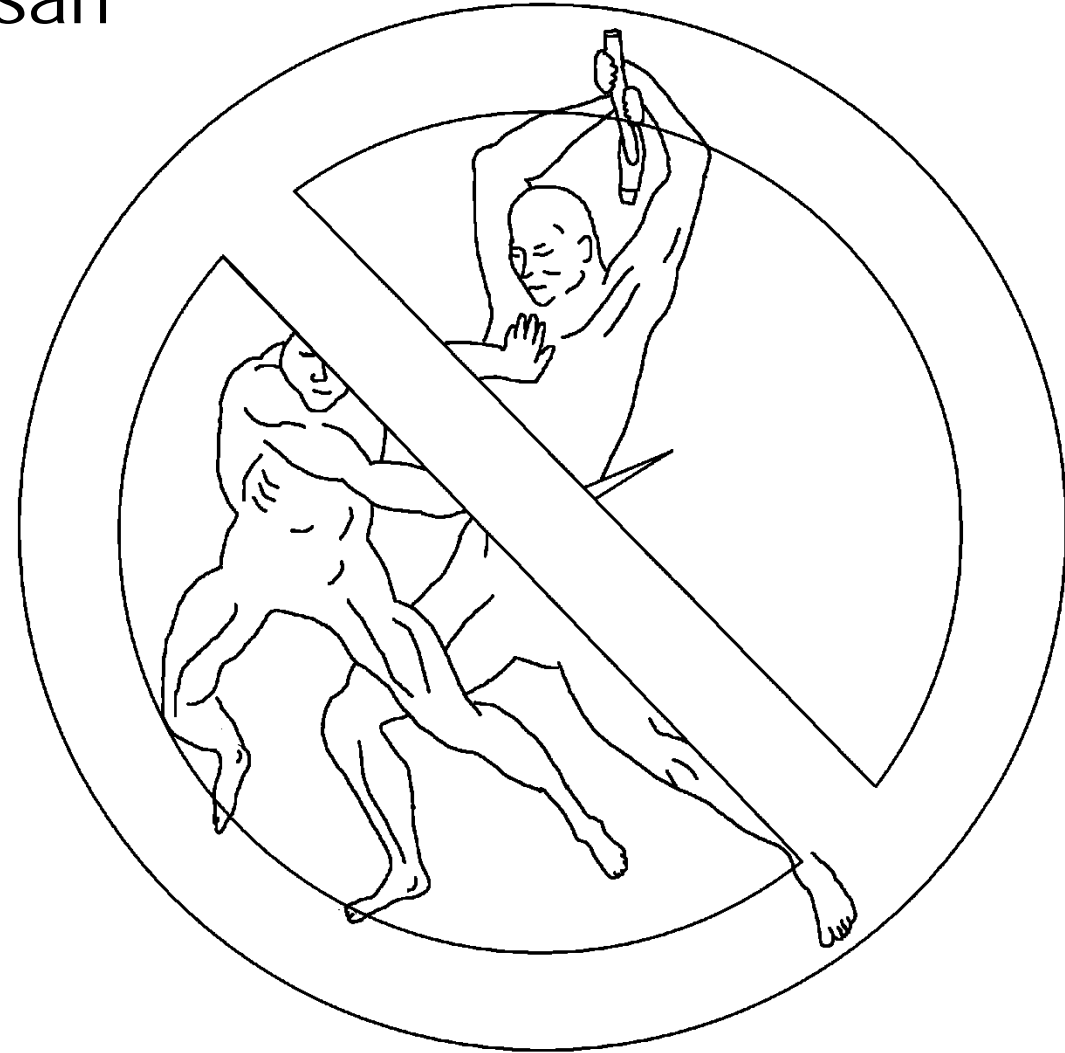

Na' gone' ka bich gat' daa
gonyeshiin legake'. Bich bi yel'
wit gat', ni kochno kwell, ni koch
no gakyeshii, ni koch no shey la,
la' ba wde çhe yog' diika' got' lo
yell-lio necha'.



Na' bibi daa nashj bia' blag' cheyin gat'ch yella', la' nan'
kwia Chioza' inabia'lene' Jesucristona', Beena' Zaklebi
to Xil'do'. Na' yog' beṅ'ka' lle' na' we'la'ogake'ne'. Na'
ile'gakile'ne'
kon ka nakyenee, na' ta'
lie'na' loxgue'ka'.



Na' ble'id' beṅ' wetka', ka beṅ' zakii na' ka beṅ' bi zakii,
zegake' lao Chioza' gana' Ilie' chṅabi'e. Na' bsalje'
librka', na'tech bsalje' sto libr yoblə gana' da' le beṅ'ka'
de yeḷ' mban ḅheyin zejli kaṅi.

Na' bene' yeḷ' josḅhis ḅhe beṅ' wetka'
kon ka choe' librka' dill' ben to toe'.

Na' bzalee lo yi' gabiḷa' beṅ'ka'
bi da' lie'ka' lee libra'
gana' da' le beṅ'ka'
de yeḷ' mban ḅheyin
zejli kaṅi.

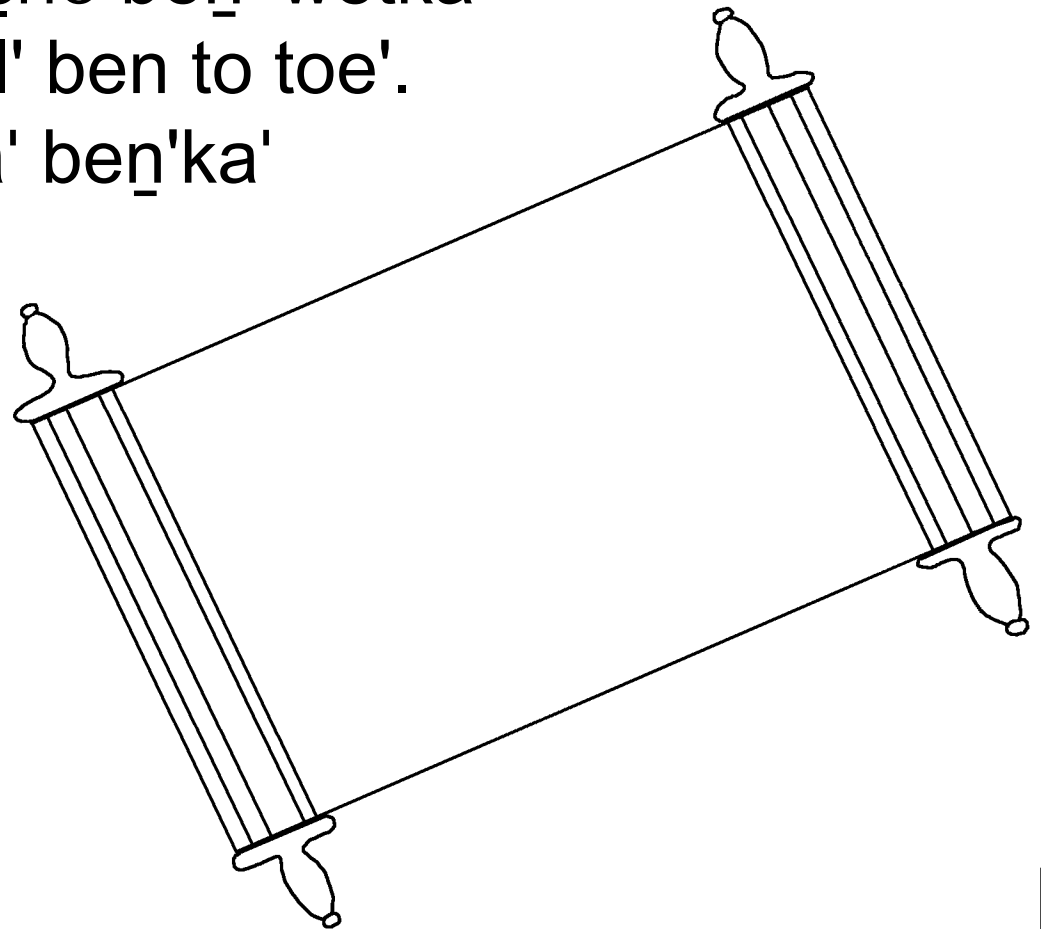

Na' Espíritu çhe Chioza', na' cho' zaklebicho noola'
wshagna'lene' Jesucrístona' daa nonlilall'chone',
che'chone': –ıBida! Na' beena' yeni dill'ki yeene':
–ıBida! Nottez' ben' chbılı, wak yide' na' yeeje' nisa' daa
nsa' yel' mbanna', na' aga bi sakile'n.

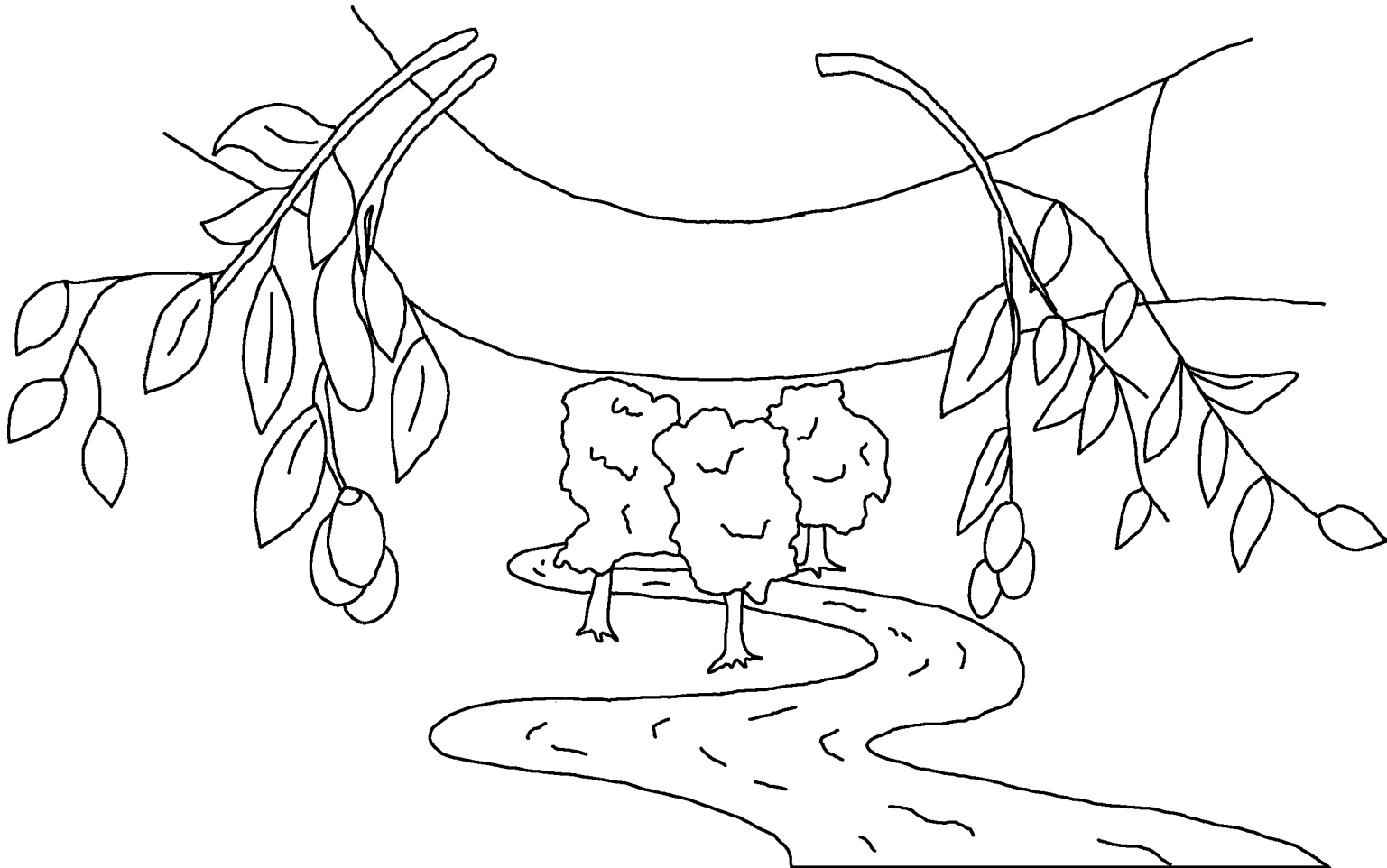

'Daa le chakchgayi Chioza' ben'
yell-lioni, bselee Xiine'na' tlish' tyaj
kwençhe nottez ben' gonlilalleene'
bi kwiayee, san gat' yel' mban
çhe' zejli kani.



Romanos 3:23 La' yog'lolzə ben' bxinj blengake' na' ni to kono nak dowalj ben' wen ka nak Chioza'.

Romanos 6:23 Laxj beena' chon saaxyana' nakan yel' wit, san daa chzani Chioza' wi'e beena' gonlilallee Xancho Cristo Jesúza' nakan to yel' mban zejli kani.

Hebreos 9:27 Na' kon ka llia bia' gak çhe to to ben' yell-lioni guete' shlinz, na'tech wçhoglo Chioza' nak gak çhe to toe',

Efesios 2:8,9 La' yel' ben' wen çhe'nan' bisle' cho' kwençhe bi kwiayi'cho daa ba nonlilallcho Crístona'. Aga inçacho daa nakcho ben' wenan bisle' cho', san nakan to goklen daa bene' çhecho ka'zə. Na' bi gak gakzcho cha'sib, la' aga daa choncho dii wennan' bisle' cho'.



Romanos 10:9,10 Shi wi'o dill' Jesúza' nake' Xancho na' shajli'o do yichj do lalloo nan Chioza' bisbane'ne' ladj ben' wetka', na' yisla Chioza' li' kwenche bi kwiayoo.

La' daa shajle'cho do yichj do lall'chon, yiyakcho ben' li ben' shao' lao Chioza', na' lekzka' daa choe'cho dill' nan Crístona' nake' Xancho, yisle' cho' kwenche bi kwiayi'cho.

San Juan 3:16,17 'Daa le chakchgayi Chioza' ben' yell-lioni, bselee Xiine'na' tlish' tyaj kwenche nottez ben' gonlilalleene' bi kwiayee, san gat' ye! mban che' zejli kani. Chioza' bselee xiine'na' yell-lioni aga kwenche wlliyee benaan, san kwenche yisle' legaken'.



1 Juan 5:11-13 Na' dillaa bi'e nan: ba bene' cho' yel' mban zejli kani, na' bene'n daa nonlilall'cho Xiine'na'.
Beena' nake' Xiin Chioza' tozə, de yel' mban çhe' zejli kani, na' beena' bi nake' Xiin Chioza' tozə, bi gat' yel' mban çhe' zejli kani. Chzej' le' dill'ki, ka le' nonlilall'le Xiin Chioza', kwençhe inezile ba de yel' mban çhele zejli kani.



San Juan 14; 2 Corintios 5; Apocalipsis 4, 21, 22

Storyline by: Edward D. Hughes

Illustrated by: Lazarus
and Alastair Paterson

Adapted by: Sarah S.

Zapotec Cajonos NT (zad) © 2011, Wycliffe Bible
Translators, Inc. All rights reserved.

<https://live.bible.is/bible/ZADWBT/MAT/1>

©2025 Bible for Children, Inc.

www.M1914.org

www.bibleforchildren.org

